



ENGINEERED THROUGH THE RACER'S EYES



2025
CATALOG



#HEYNICEBODY

45+ Years of Racing History

YESTERDAY, TODAY & TOMORROW... ALWAYS THE BEST!

Five Star Race Car Bodies, a division of Five Star Fabricating, Inc., was established in the late 1970s by Carl Schultz & Fran Prestay. The company began as a side job for them in response for a need for innovative sheet metal products in the stock car racing industry. From their '79 Camaro body, the product line quickly diversified to include durable thermoformed molded plastics; lightweight fiberglass; and advanced composite race car body components. Through ongoing development we perfected the art of formed windows. Our engineers devised improvements in material composition and coatings, which also led to the development of our own superior line of polycarbonate. Our racing windows are now #1 in all motorsports. As we continue to diversify into new markets, we remain dedicated to maintaining our deep roots in auto racing, by putting our experience & expertise to work for you by providing a complete line of the greatest racing products for years to come.



» *Headquarters*

Our clean and modern 6 building campus spans over 300,000 sq feet of floorspace and is built on 44 acres in beautiful Twin Lakes, WI. This ever evolving facility features the best production equipment & manufacturing processes to achieve the highest standards.

» *'79 Camaro*

Carl & Fran's first production of the 1979 Camaro. Word of mouth and later a small ad in Stock Car Racing Magazine led to a tremendous response from racers across the country.



» *ISO Certified*

Celebrating our 12th year of ISO 9001:2015 Certification. We are proud of the continuous improvements that make our production processes faster and more efficient while reducing waste along the way. ISO is the American Standard for quality management systems. For us, it is all about delivering the highest quality products to our customers.





» *Family Owned & Operated*

We are proud to be a family-owned and operated business, dedicated to quality and service. Carl, our founder, remains actively involved each day, sharing his expertise and passion. Today, his children, Corey, Garrett & Haley, along with Corey’s wife Heidi, are leading the way, carrying on his legacy & commitment to excellence.



» *Connecting With Racers*

Every year, we showcase groundbreaking designs at the PRI Show, demonstrating our commitment to pushing the limits of performance and durability. Beyond the show, our dedicated team attends over 100 races annually, providing racers with the support & attention they need.



» *The Future*

After 4 decades, Five Star established itself as the leader across multiple motorsports markets. As we strive to stay on the cutting edge in products and service, we’re excited to announce that in 2024, we broke ground on a state-of-the-art distribution facility in Concord, North Carolina. This facility will serve as our new Dealer Service Center, currently located in Troutman.

TABLE OF CONTENTS

ADVANCED COMPOSITES.....	4
ULTRAGLASS COMPOSITES	5
HIGH-IMPACT PLASTIC	6
POLYCARBONATE WINDOWS.....	7
WHAT'S NEW.....	8-17
ABC NEXTGEN.....	16-25
ORIGINAL ABC.....	26-35
NEXTGEN LATE MODEL STOCK	36-43
SHORT TRACK TRUCK.....	44-49
PAVEMENT MODIFIED	50-53
OUTLAW LATE MODEL	54-57
NORTH AMERICAN SPORTSMAN.....	58-64
OLDER BODY STYLES	65
CROWN VIC INTERCEPTOR	66
BANDOLERO & LEGEND CAR WINDOWS.....	67
MD3 LATE MODEL.....	68-79
MD3 MODIFIED	80-87
NORTHEAST MODIFIED.....	88-89
MD3 STOCK CAR.....	90-95
STREET STOCK	96-101
TA2 ROAD RACING.....	102-111
PRO STOCK/MOD	112-119
TOP ALCOHOL FUNNY CAR.....	120-125
JUNIOR ROADSTER.....	126-127
RACING WINDOWS	128-143
BODY ACCESSORIES	144-167
PLASTIC NOSES & BUMPER COVERS... ..	168-171
MERCHANDISE	172-175
INDEX, TERMS & CONDITIONS	176-177
MEET THE TEAM & FAMILY VALUES.....	178-179

Advanced Composites

LIGHTWEIGHT, RIGID & EXTREMELY DURABLE

WHY FIVE STAR IS BETTER!

CUSTOM ENGINEERED MATERIALS

- » Incredibly strong shear & tear resistant
- » Flame retardant resins in most applications
- » Rigid no surface deflection at high speeds
- » Durable parts do not break apart

PRECISION WEIGHT CONTROL

- » Parts made with the tightest weight tolerances

FLAWLESS FINISH

- » Excellent surface finish and wrapped in a protective film



OUR PROPRIETARY FABRIC & RESIN BLENDS ARE MADE WITH A SUPERIOR MANUFACTURING PROCESS THAT MANY TRY TO EMULATE, BUT FAIL TO REPLICATE!

ENVIRONMENTALLY SOUND MANUFACTURING

- » All parts are manufactured in our clean EPA & OSHA compliant facility

EXCELLENT SHAPE TOLERANCE FOR REPEATABLE FIT

- » In house pattern & tool production assures great shape control

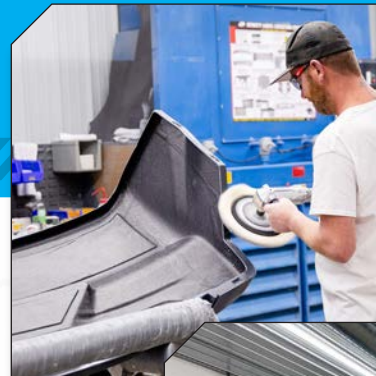

Ultraglass Composite

THE HIGH-TECH ALTERNATIVE TO OTHER FIBERGLASS COMPOSITES

FIBERGLASS PANELS REDEFINED!

UNMATCHED STRENGTH

- » Unmatched impact resistance; no other composite is stronger.
- » Panels that deflect 300% further before breaking equals less debris on the race track and less time in the pits
- » No surface deflection at high speeds

SUPREME FINISH

- » All panels are made with a smooth inner surface
- » Most panels feature a black inner finish to eliminate painting
- » Superior surface finish & wrapped in a protective plastic film
- » Excellent shape tolerance with a repeatable fit



WITH AN UNMATCHED PERFORMANCE, OUR EXCLUSIVE ULTRAGLASS COMPOSITE BLEND OUTPERFORMS ALL OTHER COMPOSITE PANELS ON THE MARKET!

ENVIRONMENTALLY SOUND MANUFACTURING

- » 93% reduction in harmful emissions during the manufacturing process
- » All parts are manufactured in our clean EPA & OSHA compliant facility

PRECISION WEIGHT CONTROL

- » Can be lighter than standard fiberglass composite panels
- » Ability to hold much tighter weight tolerances

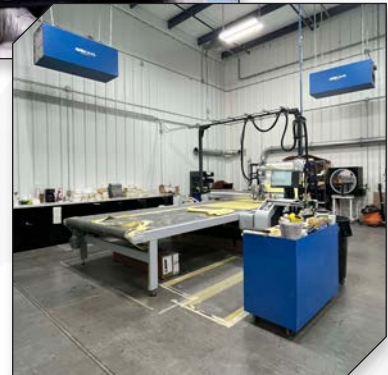

High-Impact Plastics

UNSURPASSED IMPACT RESISTANCE & DURABILITY

YOU WON'T FIND A BETTER PLASTIC!

ENGINEERED TO WITHSTAND EXTREME CONDITIONS

- » High elongation provides superior flexibility & structural integrity
- » Made with our own state of the art proprietary blend of plastic material
- » Some plastics are fire resistant & pass industry testing standards
- » We match the plastic materials for specific applications

SUPERIOR SHAPE CONTROL

- » Parts are formed using advanced computer automated thermoforming machines with temperature controlled cast aluminum tooling
- » Consistent shape tolerance allows for easy replacement
- » Shaped with even thickness & consistent part weight
- » Matched plastic materials for specific applications
- » Durable parts do not break apart

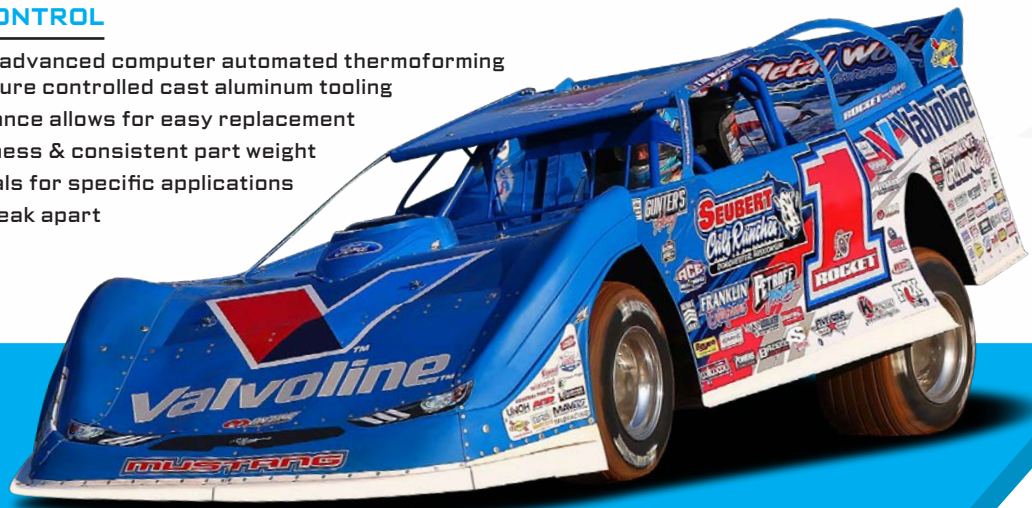

THIS FEATURED PLASTIC IS USED IN THE MD3 BRAND. THE UNDISPUTED BEST BODY PANELS IN ALL OF DIRT RACING!



EXCELLENT SHAPE TOLERANCE FOR REPEATABLE FIT

- » In house forming assures great shape control

THE MD3 ADHESION PROMOTER WORKS BEST

- » Our MD3 brand Adhesion Promoter is specifically engineered for the special plastic materials we use.



Polycarbonate Windows

THE #1 CHOICE BY TOP RACERS & TEAMS WORLDWIDE

SUPERIOR OPTICS & SAFETY!

WE CAN SHAPE FORM ANY WINDOW

- » We can meet all of your polycarbonate & acrylic needs, not just racing windows
- » We can form windows from factory glass for limited quantity orders
- » We offer in-house design & mold building for any windows you need
- » CNC pattern cutting

BETTER THAN GLASS

- » Up to 50% weight savings compared to glass
- » Can be formed into multiple shapes or styles
- » Multiple thickness & tint options available
- » Enhances driver safety



THE #1 LINE OF WINDOWS USED IN ALL OF MOTORSPORTS
BECAUSE OF IT'S SUPERIOR OPTIC CLARITY
AND UNMATCHED SAFETY!

PRECISION FIT GUARANTEED

- » Proprietary forming process ensures unrivaled optical clarity and accurate shape control
- » CNC routing ensures a perfect drop-in fit, every time

SUPERIOR OPTICAL CLARITY & DURABILITY

- » We use only the highest Optical Grade Polycarbonate
- » The highest abrasion, chemical and UV resistance
- » Windows printed with a durable black ink border
- » We have invested in our own custom built coating facility. Our coatings are robotically applied in an environmentally controlled, clean room system. We have the capability to apply a variety of coating technologies to meet a vast array of performance characteristics from hard coats to anti-fog properties. Our coating systems can be applied to either flat or complex shape components offering a solution for any application.



THE ALL NEW MD3

STOCK CAR

THE FUTURE OF STOCK CAR RACING STARTS HERE!



COMPOSITE HOOD
DESIGNED FOR
SEAMLESS AIRFLOW



LEFT & RIGHT
TOP ROLLED ALUMINUM
DOOR PANELS



LEFT & RIGHT
HIGH-IMPACT PLASTIC
QUARTER PANELS

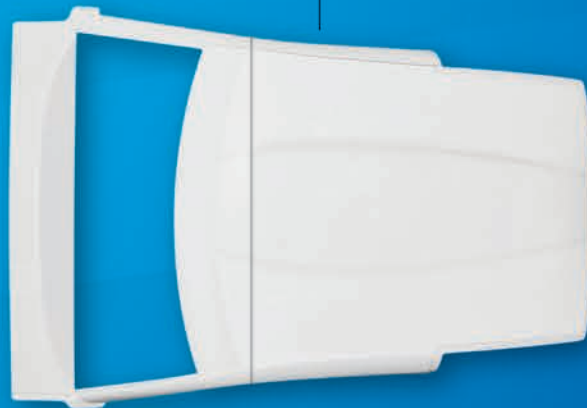

LIGHTWEIGHT & DURABLE
2-PIECE COMPOSITE ROOF WITH
INTEGRATED COWL PANEL

FOR DETAILED ORDERING INFORMATION GO TO PAGES: 90 - 95

MD3RACE.COM

NEW MD3 PRODUCTS FOR **DIRT RACING**

PRODUCTS BUILT TO WITHSTAND THE TOUGHEST CONDITIONS!



MD3 AIR FILTER SHIELD FOR UNEXPECTED WEATHER PROTECTION AT THE TRACK

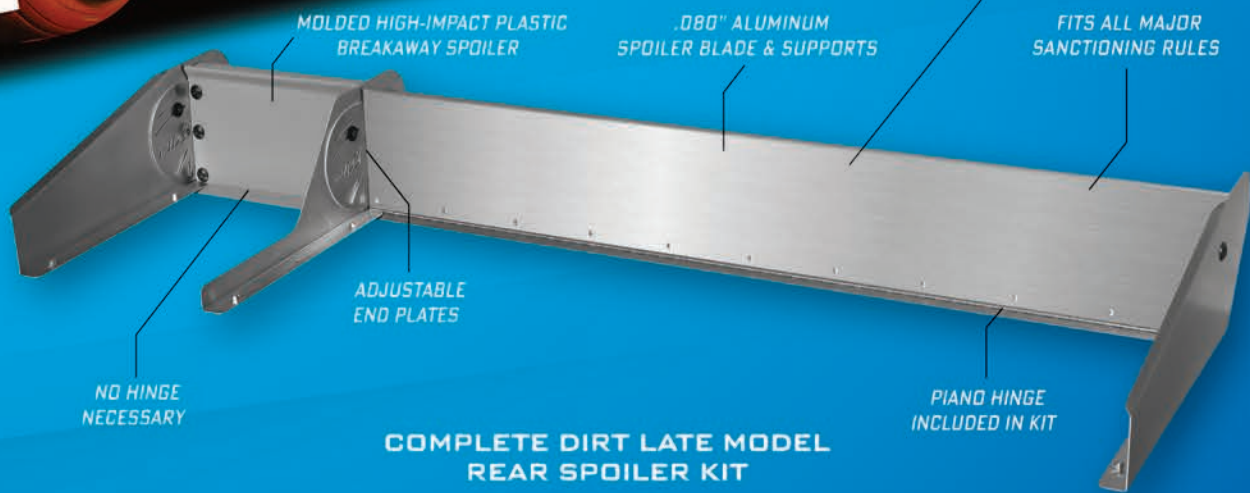

MOLDED HIGH-IMPACT PLASTIC
BREAKAWAY SPOILER

.080" ALUMINUM
SPOILER BLADE & SUPPORTS

FITS ALL MAJOR
SANCTIONING RULES

NO HINGE
NECESSARY

ADJUSTABLE
END PLATES

PIANO HINGE
INCLUDED IN KIT

COMPLETE DIRT LATE MODEL
REAR SPOILER KIT

FOR DETAILED ORDERING INFORMATION GO TO PAGES: 73, 77 & 85

MD3RACE.COM

NEW NORTHEAST MODIFIED **BODY PANELS**

UNMATCHED DURABILITY FOR THE BEASTS OF THE NORTHEAST!



HIGH-IMPACT PLASTIC
QUARTER PANELS

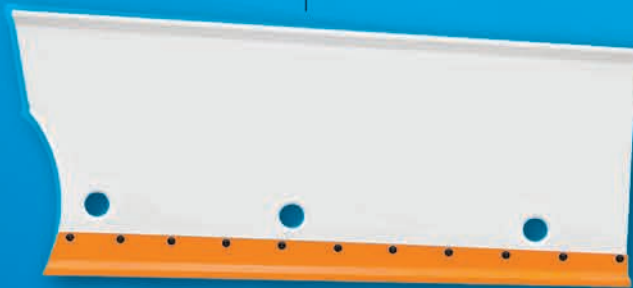

HIGH-IMPACT PLASTIC
DOOR PANELS

THE DODGE CHARGER JUNIOR DRAGSTER

ADVANCED LIGHTWEIGHT COMPOSITE FOR MAXIMUM SPEED!

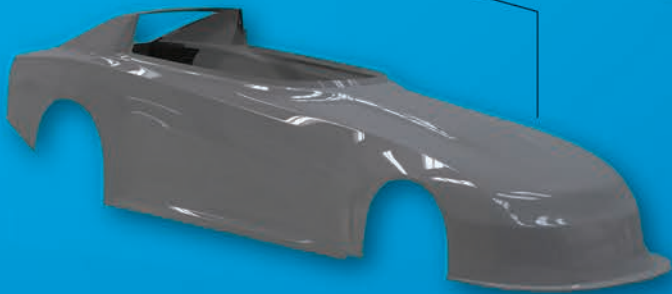

- » ADVANCED LIGHTWEIGHT COMPOSITE BODY
- » COMES WITH A GRAY, READY TO PAINT SURFACE
- » FITS AN 85-½" WHEELBASE CHASSIS
- » WEIGHS UNDER 30 LBS

FOR DETAILED ORDERING INFORMATION GO TO PAGES: 88 & 126

#HEYNICEBODY

THE NEW CROWN VIC **INTERCEPTOR** NOSE & BUMPER COVER



HIGH-IMPACT PLASTIC
CROWN VIC NOSE AVAILABLE
IN WHITE OR BLACK



HIGH-IMPACT PLASTIC
CROWN VIC BUMPER COVER
AVAILABLE IN WHITE OR BLACK

NEW BANDOLERO & LEGEND CAR WINDSHIELDS

FIND YOUR WAY TO VICTORY LANE WITH SUPERIOR OPTICS!

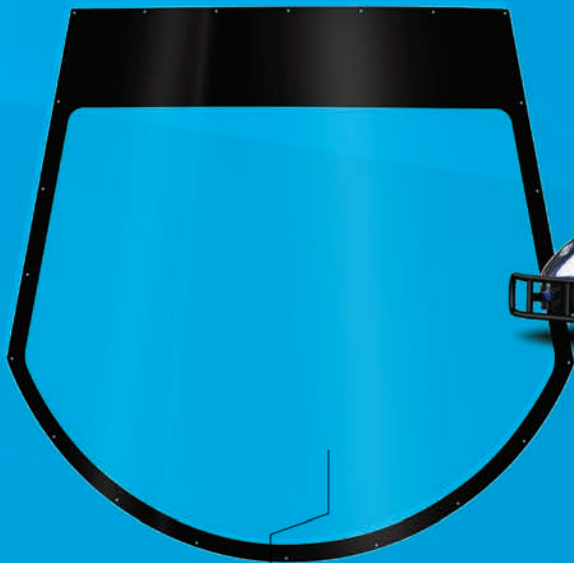

POLYCARBONATE
BANDOLERO CAR WINDSHIELD
WITH BLACKOUT BORDER



POLYCARBONATE
LEGEND CAR WINDSHIELD
WITH BLACKOUT BORDER

FOR DETAILED ORDERING INFORMATION GO TO PAGES: 66 - 67

#HEYNICEBODY

NEW NOSE FOR SPORT COMPACTS

COMING SOON IN 2025!

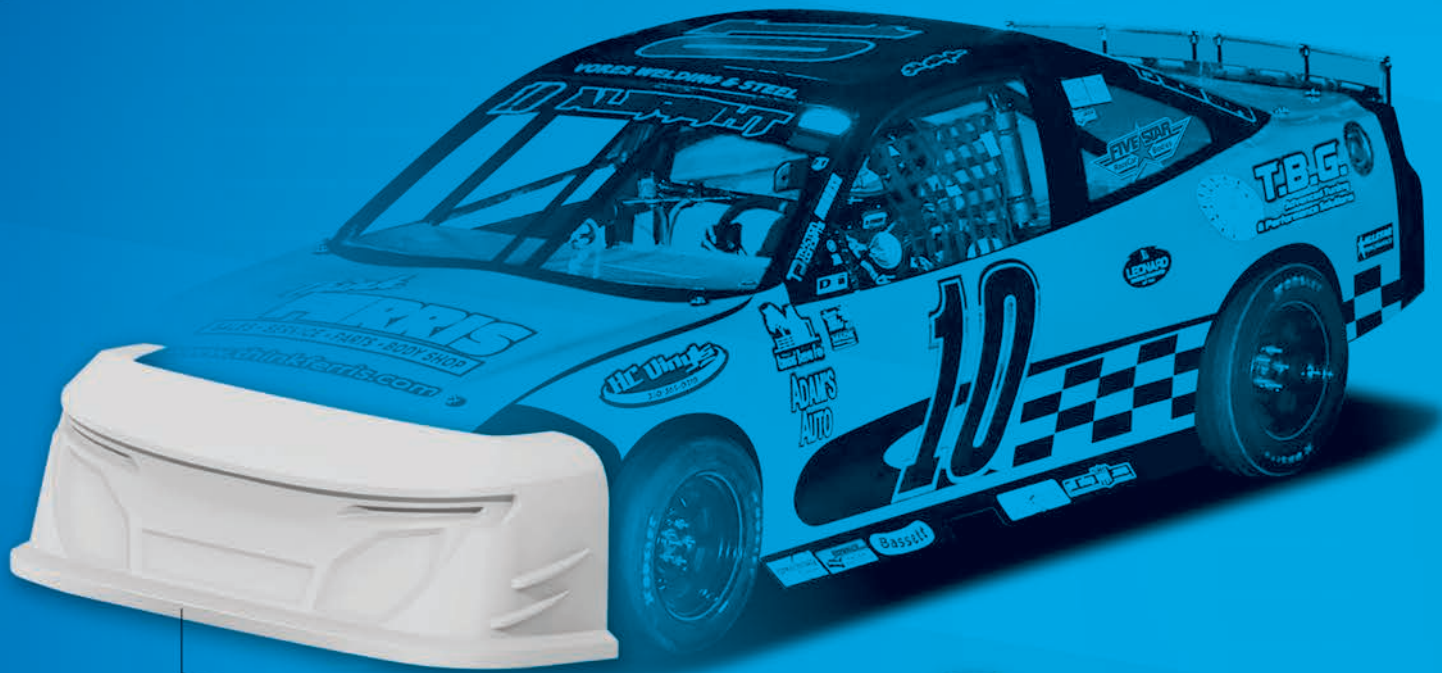

HIGH-IMPACT PLASTIC
SPORT COMPACT NOSE AVAILABLE
IN WHITE, RED, BLUE, OR BLACK



UNIVERSAL DESIGN ELEVATES
BOTH PERFORMANCE & STYLE!

ESSENTIAL FOR A CLEAN & PROFESSIONAL LOOK FEATURED PRODUCTS FOR 2025!

PREMIUM ADJUSTABLE BODY BRACES

- » AVAILABLE IN THREE OPTIONS: ALUMINUM, NYLON, OR STEEL
- » ADJUSTABLE TO A MAXIMUM LENGTH OF 30-1/2"
- » STAMPED, BLACK ANODIZED ALUMINUM MOUNTING ENDS
- » THUMB SCREW FOR QUICK, EASY LENGTH ADJUSTMENTS WITHOUT TOOLS
- » KITS COME COMPLETE IN A PACK OF 2
- » FOR MORE DETAILS & ORDERING INFO, SEE PAGE 165

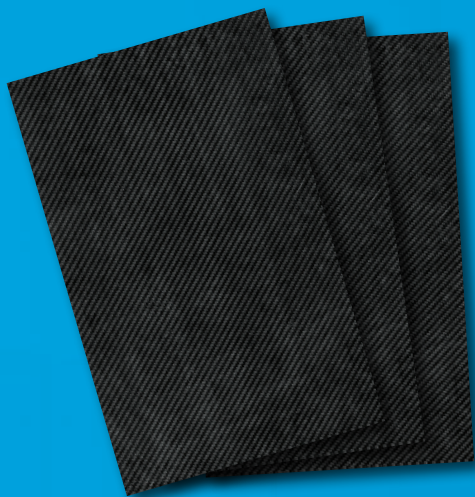

PREMIUM CARBON FIBER FLAT SHEETS

- » TRUE COSMETIC CARBON FIBER SURFACE FINISH
- » FLAT SHEETS ALLOW YOU TO CUSTOM FIT YOUR NEEDS
- » VERY HIGH STRENGTH TO WEIGHT RATIO & HEAT TOLERANCE
- » EXCELLENT VIBRATION DAMPING CHARACTERISTICS
- » LAMINATED FOR ADDITIONAL STRENGTH & DURABILITY
- » PERFECT FOR INTERIOR ACCENT PANELS
- » FOR MORE DETAILS & ORDERING INFO, SEE PAGES 119 OR 123

2'X4' & 4'X8' FLAT SHEETS
READY TO CUT & FIT!

PREMIUM AVEX STYLE MULTI-GRIP RIVETS

- » THE BEST QUALITY RIVETS ON THE MARKET
- » OUR RIVETS HAVE A SUPER-TIGHT GRIP & WON'T SPIN WHILE DRILLING
- » USE LONG SHANK RIVETS FOR FASTENING FENDER, DOOR, & WINDSHIELD POST TOGETHER
- » AVAILABLE IN UNPAINTED, WHITE, BLACK, BLUE & RED
- » FOR MORE DETAILS & ORDERING INFO, SEE PAGE 146



#HEYNICEBODY

ENGINEERED THROUGH THE DRIVER'S EYES



ABC NEXTGEN

THE MOST ADVANCED BODY ON THE MARKET

The ABC NextGen Body redefines high-performance engineering, combining unmatched durability with cutting-edge aerodynamics for superior results on the track. Designed for easy installation and minimal setup, this body gives racers the competitive edge without the hassle.



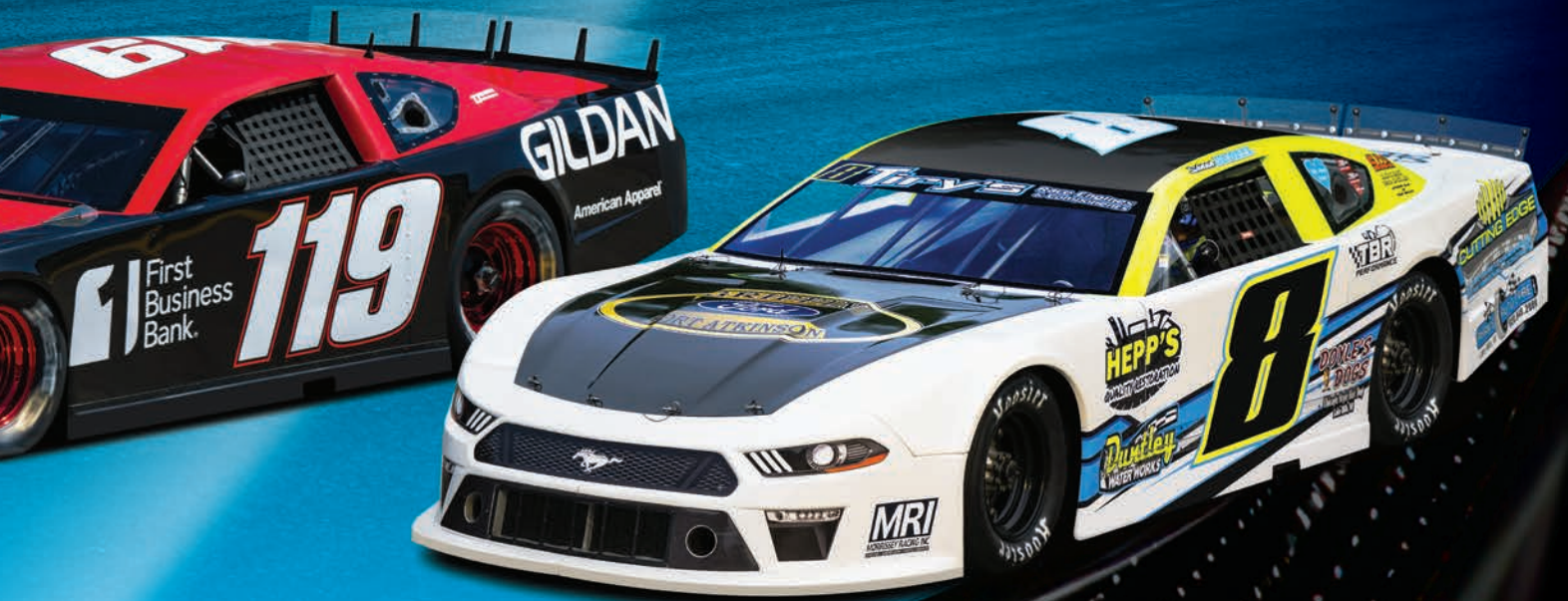

- » Additional engine clearance with more fender clearance for suspension travel
- » Exceptional aero balance achieved and validated through extensive wind tunnel & on track testing
- » Wider greenhouse increases driver access & accommodates wider roll cages
- » Enhanced safety with the use of flame-retardant resin in the Advanced Lightweight Composite Greenhouse
- » Two-piece greenhouse includes a built-in cowl & deck lid filler
- » All panels feature a consistent fit with mounting flanges, locating tabs, and minimal trimming for easy installation & replacement
- » Common body has 3 nose options for brand identity
- » Available in 4 color options



CONNECT WITH TEAM FIVE STAR | FIVESTARBODIES.COM    

ABC NEXTGEN

BODY PACKAGES & OPTIONS

HOW TO ORDER YOUR BODY IN 3 QUICK & EASY STEPS

» 1. SELECT BODY PACKAGE » 2. SELECT PANEL COLOR » 3. SELECT NOSE MAKE

RE-SKIN BODY PACKAGE		-W	-B	-CB	-R
Bumper Cover, Rear, high-impact plastic	11002-45051-x	\$155		\$160	
Door, aluminum, left	11002-21033-xL	\$112		\$112	
Door, aluminum, right	11002-21033-xR	\$112		\$112	
Fender, high-impact plastic, left	11002-23051-xL	\$150		\$154	
Fender, high-impact plastic, right	11002-23051-xR	\$150		\$154	
Nose, high-impact plastic (SPECIFY MAKE: CAMARO-11132; MUSTANG-11322; CAMRY-11712)	11xx2-41051-x	\$164		\$171	
Quarter Panel, high-impact plastic, left	11002-27351-xL	\$134		\$142	
Quarter Panel, high-impact plastic, right	11002-27351-xR	\$134		\$142	
Rocker Panel, fits either side, high-impact plastic (2 REQUIRED) SPECIFY COLOR:	000-5501P-x	\$33		\$38	
Rocker Panel, fits either side, high-impact plastic (ENTERED TWICE TO SHOW PACKAGE PRICE)	000-5501P-x	\$33		\$38	
RE-SKIN BODY PACKAGE PRICE	11002-10000-x	\$1,177		\$1,223	

COMPLETE BODY PACKAGE (RE-SKIN COMPONENTS PLUS ITEMS BELOW)		-W	-B	-CB	-R
Cowl Air Insert, Ultraglass composite	661-5100A-x	\$72		\$75	
Deck Lid Hold-Down Strip, aluminum	XM 000-310H-x	\$10		\$10	
Deck Lid, aluminum	661-310A-x	\$76		\$76	
Greenhouse, Front with built-in cowl, composite	11002-51311-x	\$400		\$464	
Greenhouse, Rear, composite	11002-51511-x	\$480		\$552	
Hood, composite	11002-33011-x	\$320		\$360	
*Spoiler, Complete, 4pc, 1/4" poly blades, unpainted brackets, 6-1/2" x 64-1/2", 70°	11002-47387	\$139		\$139	
Windshield, mar-resistant coated, 1/8"	11002-63253	\$377		\$377	
Windows, Quarter, mar-resistant coated, 0.093", left	11002-65153-L	\$65		\$65	
Windows, Quarter, mar-resistant coated, 0.093", right	11002-65153-R	\$65		\$65	
Window, Rear, uncoated, 0.093"	11002-61151	\$201		\$201	
COMPLETE BODY PACKAGE PRICE	11002-10600-x	\$3,382		\$3,607	

*ALL WINDOWS ARE PRECUT TO FIT, BEVELED & DRILLED, WITH BLACK-OUT BORDER UNLESS OTHERWISE SPECIFIED.

TO ENHANCE YOUR BODY PACKAGE, CHOOSE FROM THE OPTIONS BELOW:

BODY PACKAGE OPTIONS & UPGRADES (ADD OR SUBTRACT TO PACKAGE PRICE ABOVE FOR TOTAL)		-W	-B	+/- PKG PRICE	-CB	-R	+/- PKG PRICE
Door, with fender mounting recess, aluminum, left / right (BODY PKG PRICE IS X2)	11002-21233-xLorR	\$112	\$0	\$112	\$0	\$112	\$0
Door, for longer wheelbase, aluminum, left / right (SPECIAL ORDER) (BODY PKG PRICE IS X2)	11002-21133-xLorR	\$112	\$0	\$112	\$0	\$112	\$0
Fender, Ultraglass composite, left / right (BODY PKG PRICE IS X2)	11002-23013-xLorR	\$295	+\$145	\$325	+\$171	\$325	+\$171
Greenhouse, Front, advanced lightweight composite	11002-51312-x	\$955	+\$555	\$955	+\$491	\$955	+\$491
Greenhouse, Rear, advanced lightweight composite	11002-51512-x	\$995	+\$515	\$995	+\$443	\$995	+\$443
Quarter Panel, Ultraglass composite, left / right (BODY PKG PRICE IS X2)	11002-27313-xLorR	\$326	+\$192	\$382	+\$240	\$382	+\$240
Rocker Panels, fits either side, aluminum (BODY PKG PRICE IS X2)	000-5501A-x	\$39	+\$6	\$39	+\$1	\$39	+\$1
Hood, oversized, advanced lightweight composite	11002-33011L-x	\$619	+\$299	\$619	+\$259	\$619	+\$259
Window, Rear, mar-resistant coated, .093"	11002-61153	\$347	+\$146	\$347	+\$146	\$347	+\$146
Spoilers: 60" wide							
Complete, aluminum	11002-47359						
Complete, aluminum, black	11002-47359-B						
Spoilers: 64-1/2" wide							
Complete, aluminum	11002-47379						
Complete, aluminum, black	11002-47379-B						

*70° SPOILER PREFERRED FOR OPTIMUM AERO PERFORMANCE

ABC NEXTGEN

BODY MOUNTING KIT

» EVERYTHING YOU NEED FOR THAT CLEAN & PROFESSIONAL INSTALL!

COMPLETE BODY MOUNTING KIT SAVE \$\$ WHEN PURCHASING COMPLETE KIT VERSUS INDIVIDUAL COMPONENTS!

Adjustable Body Braces (X3 @ \$35 EACH)	807-3	\$105
Aluminum Nose Side Braces, pair	11002-75333	\$15
Door Vent Windows, pair	11002-66222	\$38
Front Bumper Mounting Kit	10001-72721	\$132
Front Bumper, 1-3/4", .065" steel	11002-71182	\$48
Graphics, Nose ID Kit (SPECIFY MAKE BELOW)	11xx2-44141	\$39
Graphics, Bumper Cover ID Kit (SPECIFY MAKE BELOW)	xxxx2-44541	\$38
Hood Pin Bracket, 3/4" steel (4 PINS REQUIRED)	11002-34331	\$35
Hood Pin Kit, 3/8" pins (X2 @ \$16EA) SPECIFY COLOR: -B -CB -R	10001-34033-x	\$32
Nose Screen, stainless, 3/16"	660-4111	\$50
Rear Bumper Mounting Kit	802-25	\$49
Rear Bumper, 1-3/4", .065" steel	11002-71682	\$48
Rear Deck Mounting Kit	660-450-RDK	\$89
Rear Window Brace Kit (3PC)	11002-76133	\$84
Right Side Door Support	11002-75533	\$30
Universal Body Mounting Kit, plastic	00001-72651	\$29
Wear Strips, plastic SPECIFY COLOR: -W -B -CB -OR -R -Y -FG -FO -FR -FY	11002-41551-x	\$35
Window Installation Kit	805	\$27
Windshield Brace Kit (3PC)	11002-76333	\$84
COMPLETE KIT PRICE WITH 10% DISCOUNT	11002-72520	\$906.30

BODY MOUNTING KIT OPTIONS & UPGRADES (ADD OR SUBTRACT GREEN \$ TO PACKAGE PRICE ABOVE FOR TOTAL)

Front Bumper, 1-3/4" round, .095" steel	11002-71185	\$48	\$0	Nose Screen, black, 1/4"	660-4112-B	\$55	+\$5
Front Bumper, 1-3/4" round, .095" steel W/ 12" EXT.	11002-71188	\$56	+\$8	Nose Screen, black, 3/16"	660-4111-B	\$55	+\$5
Hood Pin Bracket, 3/4" aluminum	11002-34333	\$66	+\$31	Nose Screen, black aluminum frame, 3/16"	10001-46333B	\$55	+\$5
Hood Pin Kit, 1/2" pins (5PC)	803	\$38	+\$6	Nose Screen, black aluminum frame, 1/4"	10001-46433B	\$55	+\$5
Nose Screen, 1/4"	660-4112	\$50	\$0	Universal Body Mounting Kit, aluminum	000-400k	\$49	+\$20

VINYL NOSE & BUMPER COVER GRAPHIC ID KITS FOR A REALISTIC OEM LOOK!

PRINTED ON OUTDOOR DURABLE HIGH-TACK VINYL • GLOSS LAMINATED SURFACE PROVIDES EXCELLENT PROTECTION



CHEVROLET CAMARO

Nose ID Kit	11132-44141	\$39
Bumper Cover ID Kit	11132-44542	\$38

FORD MUSTANG

Nose ID Kit	11322-44141	\$39
Bumper Cover ID Kit	11322-44541	\$38

TOYOTA CAMRY

Nose ID Kit	11712-44141	\$39
Bumper Cover ID Kit	11712-44541	\$38

» GO TO PAGES 144-167 TO SEE ALL ACCESSORIES FOR THIS BODY

PRICING SUBJECT TO CHANGE WITHOUT NOTICE

ABC NEXTGEN

FEATURED BODY ACCESSORIES



PREMIUM AVEX STYLE RIVETS:

- » Five Star Premium Rivets are known as the best quality on the market
- » Grip range up to 3/16" for 1/8" rivets & up to 1/2" for 3/16" rivets
- » Super-tight grip & won't spin out while drilling!
- » For more details & ordering info, see page 146



COWL INDUCTION COLD AIR BOXES:

- » 4 barrel and 2 barrel offset options available
- » Flow bench tested for peak air flow
- » For more details & ordering info, see page 154



LOWER NOSE SUPPORT BRACKET

- » Mounts under the lower valance to maintain strength and structural integrity for the nose under high speeds
- » Choose from a lightweight aluminum or steel bracket
- » For more details & ordering info, see page 150



FENDER-TO-NOSE BACK UP PLATES:

- » 4 Piece Kit Includes: 2 Fronts & 2 Rear Plates (enough for both sides)
- » Pre-drilled holes in the necessary locations for quick & easy mounting
- » For more details & ordering info, see page 162

» GO TO PAGES 144-167 TO SEE ALL ACCESSORIES FOR THIS BODY STYLE

ABC NEXTGEN

BODY DIMENSIONS

FIVE STAR BODIES ARE DESIGNED TO MAINTAIN PRECISE FIT WITH OPTIMIZED AERODYNAMICS!

WIDTHS

A	B	C
79½" MAX"	68"	67"

Body Width: Measured at wheel wells

Door to Door Width: Measured at A-posts & inside edge of doors, measured through car

Door to Door Width: Measured at B-posts & inside edge of doors, measured through car

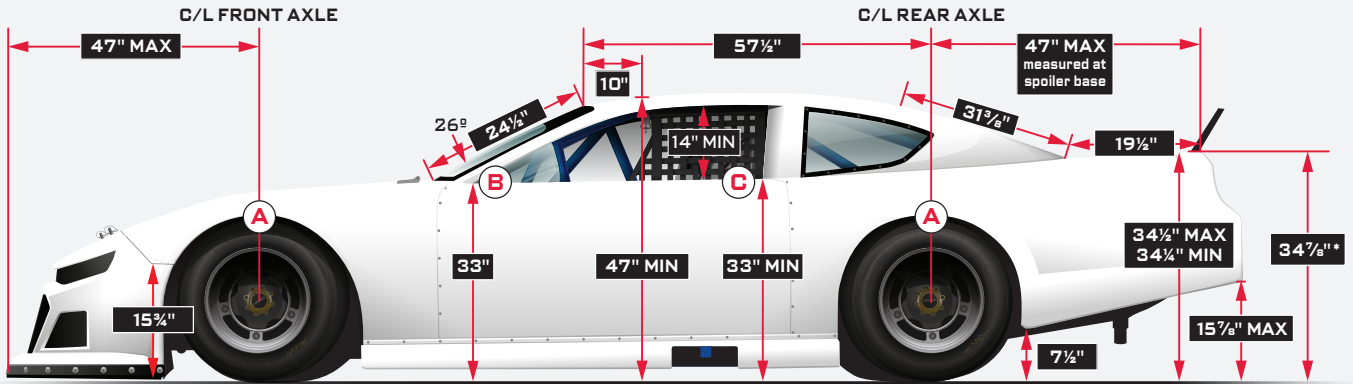

NOTES:

1. If the Roof Height (10" back from windshield), Door Height (rear), Quarter Panel, or Bumper Cover Height dimensions are higher than the stated minimum dimensions, all four must increase by the same amount.

2. Must fit centerline template within allowable tolerance. *Measured at the seam of bumper cover at deck lid intersection, +/- 1/4"

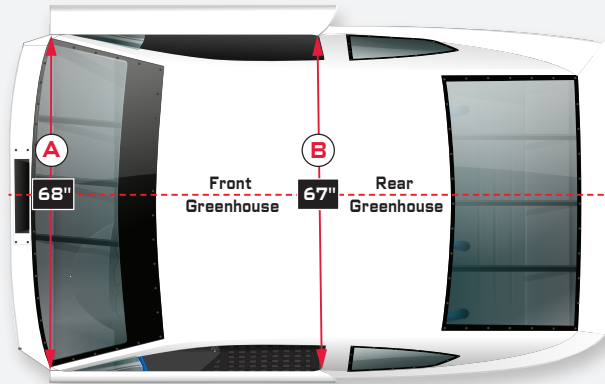

CHASSIS	ROOF HEIGHT	TREAD WIDTH	WHEELBASE
Offset/ Straight Rail	47"	66" MAX	101-106"

SCAN HERE TO SHOP ONLINE



» FOR INDIVIDUAL BODY PANEL DIMENSIONS, VISIT FIVESTARBODIES.COM

PRICING SUBJECT TO CHANGE WITHOUT NOTICE

ABC LASC TRUCK PAVMOD OUTLAW LATE MODEL SPORTSMAN OLDER BODIES MD3 LATE MODEL MD3 MODIFIED NORTHEAST MOD STOCK CAR STREET STOCK TAZ PRO STOCK/MOD FUNNY CAR JR ROADSTER WINDOWS ACCESSORIES

ABC NEXTGEN

BODY MOUNTING FIXTURES

MOUNT YOUR BODY FAST & EASY TO MAXIMIZE PERFORMANCE & HELP PASS TECH!

It is the responsibility of all competitors to present a car that fits the templates within allowable tolerances and meets all dimensions as inspected by the "Referee." Be sure to download a free copy of the Official ABC Rulebook for body styles, panels, spoilers, windows, over hangs, roof height, proper placement of templates, and more!



THE OFFICIAL REFEREE 2.0

- » Used by tracks and associations throughout North America for body tech inspection
- » Measure the front overhang of the nose, tread width, roof, door, and deck height, rear overhang, wheelbase, and engine setback
- » Adjustable laser option for accurate measurements of front overhang and engine setback
- » Magnetic, tinted polycarbonate wheel plates for better attachment to wheels
- » Includes Tech Inspector's checklist
- » **NOT NECESSARY FOR MOUNTING A BODY.** A body can easily be installed within specs by using the body dimensions sheets & templates

Referee 2.0	TT-200-00	\$2,050
Wheel Locator, w/magnets (SET OF 4) (SOLD SEPARATELY)	TT-200-WL	\$98
Laser Measurement Assembly (SOLD SEPARATELY)	TT-200-LB	\$150
Body Centerline Device (SOLD SEPARATELY)	TT-200-BC	\$195

▶ VISIT OUR YOUTUBE PAGE FOR A TECH VIDEO DEMONSTRATING USE OF THE OFFICIAL REFEREE 2.0

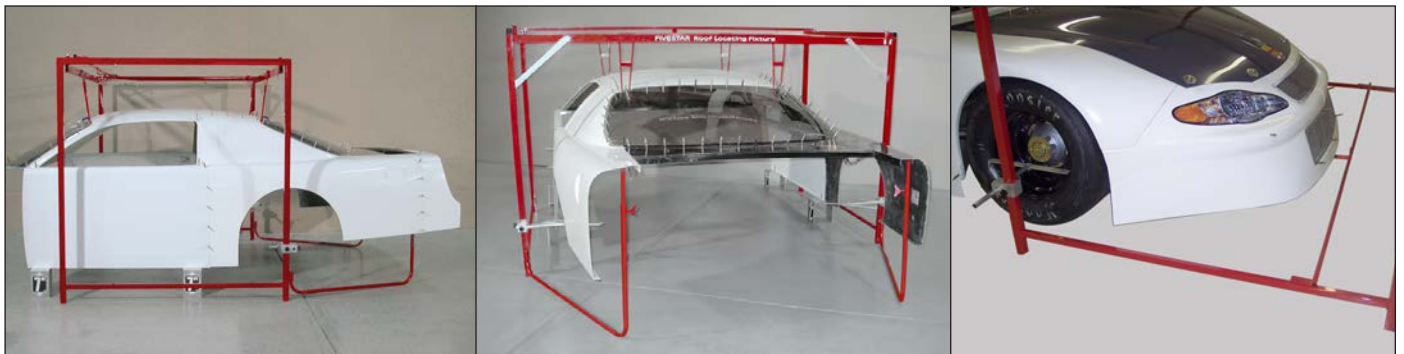

ROOF LOCATING FIXTURE

- » THE FAST & EASY WAY TO MOUNT YOUR COMPLETE BODY WITHOUT THE CHASSIS UNDERNEATH
- » This time-saving device has adjustable quarter panel arms and makes locating the roof on your chassis a simple process
- » Allows exact fit for wheel opening locations, body dimensions, and inspection templates to fit series specs
- » Pre-fits from the cowl to the bumper cover, then can be lifted easily on top of the chassis for final fit
- » Comes in a black powder-coat finish and includes roof brackets, door height blocks and assembly instructions

Roof Locating Fixture (INCLUDES ROOF BRACKETS & DOOR HEIGHT BLOCKS)	809P	\$898
Replacement Roof Brackets	11002-72231	\$71
Replacement Door Height Blocks, 6" tall	11002-72331	\$38

ABC NEXTGEN

TOOLS & TEMPLATES



ABC NEXT GEN TEMPLATES ENSURE A CORRECT FIT FOR OPTIMUM AERODYNAMICS

- » Complete template set ensures body is installed correctly
- » Complete sets include: Body Centerline, Nose Centerline, Nose Side-to-Side, Fenders, Extended Front Roof Side-to-Side, Extended Rear Roof Side-to-Side, and Rear Deck Side-to-Side
- » Common templates can check all models
- » Master sets available with templates for all models

Template, Complete Set, wood, Chevrolet Camaro	11132-82091	\$428
Template, Complete Set, wood, Toyota Camry	11712-82091	\$428
Template, Complete Set, wood, Ford Mustang	11322-82091	\$428
Template, Master Set, wood, all models	11002-82091	\$586
Template, Nose Side-to-Side, wood, Common	11002-82491	\$58
TEMPLATES FOR ENHANCED SHAPE CONTROL		
Template, Roof, Front, Side-to-Side, extended, wood, Common	11003-82591	\$75
Template, Roof, Rear, Side-to-Side, extended, wood, Common	11003-82691	\$75
Template, Rear Deck Lid, wood, Common	11003-83591	\$75



» **DOWNLOAD OFFICIAL ABC RULEBOOK @ FIVESTARBODIES.COM**

» **FOR MORE BODY MOUNTING TOOLS, GO TO PAGES 144-167**



ENGINEERED THROUGH THE DRIVER'S EYES



ORIGINAL ABC BODY

CLASSIC DESIGN, MODERN PERFORMANCE

The Original ABC Body offers two roof options: the Greenhouse, with built-in locating tabs for quick installation & durable plastic quarter panels, and the Traditional design, with integrated quarter panels with a separate deck lid filler panel. Both ensure a seamless fit & enhanced performance, making it the ideal choice for any racer.





TWO-PIECE GREENHOUSE

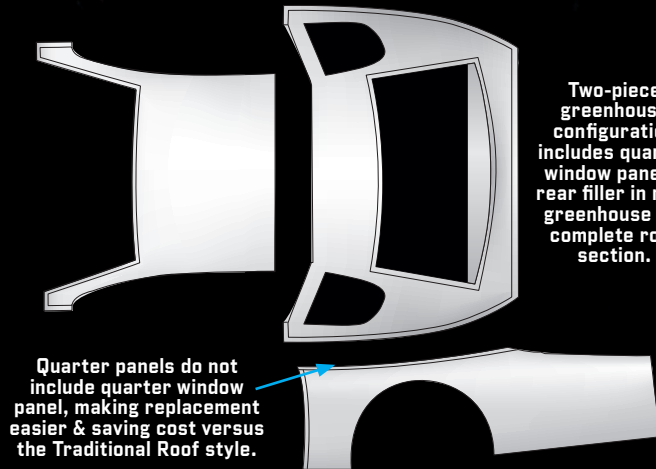

Quarter panels do not include quarter window panel, making replacement easier & saving cost versus the Traditional Roof style.

Two-piece greenhouse configuration includes quarter window panel & rear filler in rear greenhouse for complete roof section.

TRADITIONAL 1-PIECE ROOF

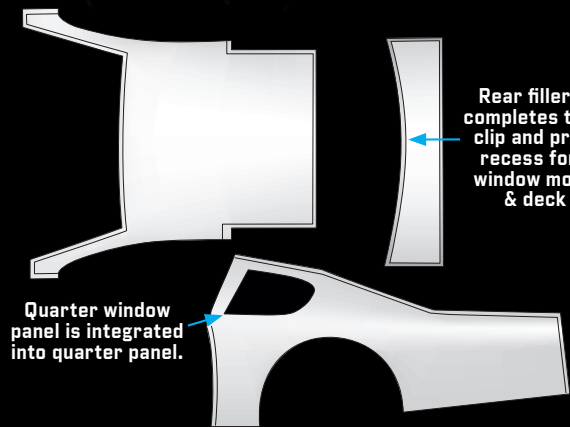

Quarter window panel is integrated into quarter panel.

Rear filler panel completes the rear clip and provides recess for rear window mounting & deck lid.

- » The most durable ABC body on the market
- » Common body has 4 different style noses
- » Available in 4 color options



CONNECT WITH TEAM FIVE STAR | FIVESTARBODIES.COM    

ABC TRADITIONAL ROOF

BODY PANELS & OPTIONS

HOW TO ORDER YOUR BODY IN 3 QUICK & EASY STEPS

» 1. SELECT BODY PACKAGE » 2. SELECT PANEL COLOR » 3. SELECT NOSE MAKE

RE-SKIN BODY PACKAGE

		-W -B	-CB -R
Bumper Cover, Rear, high-impact plastic	460-450-x	\$155	\$160
Door, aluminum, left	661-21A-xL	\$112	\$112
Door, aluminum, right	661-21A-xR	\$112	\$112
Fender, 8" tires (-23-xL) ACT SERIES; 10" tires (-24-xL), high-impact plastic, left (SPECIFY SIZE)	660-2x-xL	\$150	\$154
Fender, 8" tires (-23-xR) ACT SERIES; 10" tires (-24-xR), high-impact plastic, right (SPECIFY SIZE)	660-2x-xR	\$150	\$154
Nose, high-impact plastic (SPECIFY MAKE: CHEVY SS-660; FUSION-570; CAMRY-720; CHARGER-470 IS B/W ONLY)	xxx-410-x	\$164	\$171
Quarter Panel, Ultraglass composite, left	463-270-xL	\$410	\$450
Quarter Panel, Ultraglass composite, right	463-270-xR	\$410	\$450
Rocker Panel, fits either side, high-impact plastic (2 REQUIRED) SPECIFY COLOR: -W -B -CB -R	000-5501P-x	\$33	\$38
Rocker Panel, fits either side, high-impact plastic (ENTERED TWICE TO SHOW PACKAGE PRICE)	000-5501P-x	\$33	\$38
RE-SKIN BODY PACKAGE PRICE		583-100-x	\$1,729 \$1,839

COMPLETE BODY PACKAGE (RE-SKIN COMPONENTS PLUS ITEMS BELOW)

		-W -B	-CB -R
Cowl Panel Kit (INCLUDES COWL/DASH, COWL AIR INSERT AND TABS, ULTRAGLASS COMPOSITE WITH FIRE RETARDANT RESIN)	671-5100-x	\$267	\$301
Deck Lid Hold-Down Strip, aluminum	XM 000-310H-x	\$10	\$10
Deck Lid, aluminum	661-310A-x	\$76	\$76
Deck Lid Filler Panel, composite	661-3200-x	\$165	\$188
Roof, 1-piece, composite	661-5102-x	\$340	\$378
Hood, flat, composite	670-3301-x	\$320	\$360
Spoiler, Complete, 4pc, polycarbonate blades & unpainted aluminum brackets, 6-1/2" x 60", 70°	661-6737	\$129	\$129
Windshield, mar-resistant coated, 1/8"	564-6325-3B	\$377	\$377
Window, Quarter, mar-resistant coated, 0.093", left	460-6515BL	\$65	\$65
Window, Quarter, mar-resistant coated, 0.093", right	460-6515BR	\$65	\$65
Window, Rear, uncoated, 0.093"	574-6111-3B	\$201	\$201
COMPLETE BODY PACKAGE PRICE		583-142-x	\$3,744 \$3,989

*ALL WINDOWS ARE PRECUT TO FIT, BEVELED & DRILLED, WITH BLACK-OUT BORDER UNLESS OTHERWISE SPECIFIED.

TO ENHANCE YOUR BODY PACKAGE, CHOOSE FROM THE OPTIONS BELOW:

BODY PACKAGE OPTIONS & UPGRADES (ADD OR SUBTRACT TO PACKAGE PRICE ABOVE FOR TOTAL)

		-W -B	+/- PKG PRICE	-CB -R	+/- PKG PRICE					
Door, for longer wheelbase, aluminum, left / right (SPECIAL ORDER) (BODY PKG PRICE IS X2)	661-211A-xLorR	\$112	\$0	\$112	\$0					
Fender, for 10" tires, Ultraglass composite, left / right (BODY PKG PRICE IS X2)	663-240-xLorR	\$289	+\$139	\$329	+\$175					
Fender, for 8" tires, composite, left / right (AVAILABLE ONLY IN BLACK OR WHITE) (BODY PKG PRICE IS X2)	663-230-xLorR	\$169	+\$19	N/A	N/A					
Roof, 1-piece, advanced lightweight composite	661-5102L-x	\$624	+\$284	\$624	+\$246					
Hood, flat, advanced lightweight composite	670-3301L-x	\$585	+\$265	\$585	+\$225					
Hood, scooped, composite (AVAILABLE ONLY IN BLACK OR WHITE) NOT ABC APPROVED	660-3303-x	\$320	\$0	N/A	N/A					
Rocker Panels, fits either side, aluminum (BODY PKG PRICE IS X2)	000-5501A-x	\$39	+\$6	\$39	+\$1					
Cowl Panel Air Deflector, Ultraglass composite (AVAILABLE ONLY IN BLACK)	000-5200A	\$55	+\$55	N/A	N/A					
Window, Rear, mar-resistant coated, 0.093"	574-6115-3B	\$315	+\$114	\$315	+\$114					
Windshield, mar-resistant coated, 3/16" (FOR ENHANCED DRIVER SAFETY)	564-6335-3B	\$427	+\$50	\$427	+\$50					
Spoilers: 60" wide	5" (90°)	5" (70°)	5" (55°)	6-1/2" (90°)	6-1/2" (70°)	6-1/2" (55°)				
Complete, aluminum	661-6749	661-6747	661-6745	661-6739	661-6737	661-6735	\$129	\$0	\$129	+\$0
Complete, aluminum, black	661-6749-B	661-6747-B	661-6745-B	661-6739-B	661-6737-B	661-6735-B	\$139	+\$10	\$139	+\$10

ABC GREENHOUSE STYLE

BODY PANELS & OPTIONS

HOW TO ORDER YOUR BODY IN 3 QUICK & EASY STEPS

» 1. SELECT BODY PACKAGE » 2. SELECT PANEL COLOR » 3. SELECT NOSE MAKE

RE-SKIN BODY PACKAGE

		-W -B	-CB -R
Bumper Cover, Rear, high-impact plastic	460-450-x	\$155	\$160
Door, aluminum, left	661-21A-xL	\$112	\$112
Door, aluminum, right	661-21A-xR	\$112	\$112
Fender, 10" tires, high-impact plastic, left	660-24-xL	\$150	\$154
Fender, 10" tires, high-impact plastic, right	660-24-xR	\$150	\$154
Nose, high-impact plastic (SPECIFY MAKE: CHEVY SS-660; FUSION-570; CAMRY-720; CHARGER-470 IS B/W ONLY)	xxx-410-x	\$164	\$171
Quarter Panel, high-impact plastic, left	670-27-xL	\$134	\$142
Quarter Panel, high-impact plastic, right	670-27-xR	\$134	\$142
Rocker Panel, fits either side, high-impact plastic (2 REQUIRED) SPECIFY COLOR: -W -B -CB -R	000-5501P-x	\$33	\$38
Rocker Panel, fits either side, high-impact plastic (ENTERED TWICE TO SHOW PACKAGE PRICE)	000-5501P-x	\$33	\$38
RE-SKIN BODY PACKAGE PRICE	593-100-x	\$1,177	\$1,223

COMPLETE BODY PACKAGE (RE-SKIN COMPONENTS PLUS ITEMS BELOW)

Cowl Panel Kit (INCLUDES COWL/DASH, COWL AIR INSERT AND TABS), ULTRAGLASS COMPOSITE WITH FIRE RETARDANT RESIN	671-5100-x	\$267	\$301
Deck Lid Hold-Down Strip, aluminum	XM 000-310H-x	\$10	\$10
Deck Lid, aluminum	661-310A-x	\$76	\$76
Greenhouse, Front, composite	671-5112-x	\$298	\$324
Greenhouse, Rear, composite	671-5102-x	\$442	\$510
Hood, flat, composite	670-3301-x	\$320	\$360
Spoiler, Complete, 4pc, unpainted aluminum blades & brackets, 6-1/2" x 60", 70°	661-6737	\$129	\$129
Windshield, mar-resistant coated, 1/8"	564-6325-3B	\$377	\$377
Window, Quarter, mar-resistant coated, 0.093", left	460-6515BL	\$65	\$65
Window, Quarter, mar-resistant coated, 0.093", right	460-6515BR	\$65	\$65
Window, Rear, uncoated, 0.093"	574-6111-3B	\$201	\$201
COMPLETE BODY PACKAGE PRICE	593-142-x	\$3,427	\$3,641

*ALL WINDOWS ARE PRECUT TO FIT, BEVELED & DRILLED, WITH BLACK-OUT BORDER UNLESS OTHERWISE SPECIFIED.

TO ENHANCE YOUR BODY PACKAGE, CHOOSE FROM THE OPTIONS BELOW:

BODY PACKAGE OPTIONS & UPGRADES (ADD OR SUBTRACT TO PACKAGE PRICE ABOVE FOR TOTAL)

		-W -B	+/- PKG PRICE	-CB -R	+/- PKG PRICE					
Door, for longer wheelbase, aluminum, left / right (SPECIAL ORDER) (BODY PKG PRICE IS X2)	661-211A-xLorR	\$112	\$0	\$112	\$0					
Fender, for 10" tires, Ultraglass composite, left / right (BODY PKG PRICE IS X2)	663-240-xLorR	\$289	+\$139	\$329	+\$175					
Fender, for 8" tires, composite, left / right (AVAILABLE ONLY IN BLACK OR WHITE) (BODY PKG PRICE IS X2)	663-230-xLorR	\$169	+\$19	N/A	N/A					
Fender, 8" tires ACT SERIES, high-impact plastic, left / right	660-23-xLorR	\$150	\$0	N/A	N/A					
Greenhouse, Front, advanced lightweight composite	671-5112L-x	\$539	+\$241	\$539	+\$215					
Greenhouse, Rear, advanced lightweight composite	671-5102L-x	\$954	+\$512	\$954	+\$444					
Hood, flat, advanced lightweight composite	670-3301L-x	\$585	+\$265	\$585	+\$225					
Hood, scooped, composite (AVAILABLE ONLY IN BLACK OR WHITE) NOT ABC APPROVED	660-3303-x	\$320	\$0	N/A	N/A					
Quarter Panel, Ultraglass composite, left / right (BODY PKG PRICE IS X2)	673-270-xLorR	\$326	+\$192	\$382	+\$240					
Rocker Panels, fits either side, aluminum (BODY PKG PRICE IS X2)	000-5501A-x	\$39	+\$6	\$39	+\$1					
Cowl Panel Air Deflector, Ultraglass composite (AVAILABLE ONLY IN BLACK)	000-5200A	\$59	+\$59	N/A	N/A					
Window, Rear, mar-resistant coated, 0.093"	574-6115-3B	\$315	+\$114	\$315	+\$114					
Windshield, mar-resistant coated, 3/16" (FOR ENHANCED DRIVER SAFETY)	564-6335-3B	\$427	+\$50	\$427	+\$50					
Spoilers: 60" wide	5" (90°)	5" (70°)	5" (55°)	6-1/2" (90°)	6-1/2" (70°)	6-1/2" (55°)				
Complete, aluminum	661-6749	661-6747	661-6745	661-6739	661-6737	661-6735	\$129	\$0	\$129	+\$0
Complete, aluminum, black	661-6749-B	661-6747-B	661-6745-B	661-6739-B	661-6737-B	661-6735-B	\$139	+\$10	\$139	+\$10

PRICING SUBJECT TO CHANGE WITHOUT NOTICE

ORIGINAL ABC BODY STYLES

BODY MOUNTING KIT

» EVERYTHING YOU NEED FOR THAT CLEAN & PROFESSIONAL INSTALL!

COMPLETE BODY MOUNTING KIT SAVE \$\$ WHEN PURCHASING COMPLETE KIT VERSUS INDIVIDUAL COMPONENTS!

Adjustable Body Braces (X3 @ \$35EA)	807-3	\$105
Aluminum Nose Side Braces, pair	000-500	\$39
Door Vent Windows, pair	000-6202	\$39
Front Bumper Mounting Kit	10001-72721	\$132
Front Bumper, 1-3/4", .065" steel	660-7103	\$48
Graphics, Nose ID Kit (SPECIFY MAKE BELOW)	xx0-410-ID	\$39
Graphics, Bumper Cover ID Kit (SPECIFY MAKE BELOW)	xx0-450-ID	\$38
Hood Pin Bracket, 1/2" steel (5 PINS REQUIRED; SPECIFY MAKE PG 129)	xx0-410-HPB	\$35
Hood Pin Kit, 3/8" pins (X3 @ \$16EA) -B -CB -R	10001-34033-x	\$48
Nose Screen, stainless, 3/16"	660-4111	\$50
Rear Bumper Mounting Kit	802-25	\$49
Rear Bumper, 1-3/4", .065" steel	570-7503	\$48
Rear Deck Mounting Kit	660-450-RDK	\$89
Rear Window Brace Kit (3PC)	674-6101	\$84
Right Side Door Support	11002-75533	\$30
Universal Body Mounting Kit, plastic	00001-72651	\$29
Wear Strips, plastic SPECIFY COLOR: -W -B -CB -OR -R -Y -FG -FO -FR -FY	000-400-x	\$35
Window Installation Kit	805	\$27
Windshield Brace Kit (3PC)	564-6301	\$84
COMPLETE KIT PRICE WITH 10% DISCOUNT	800-ID	\$943.20

BODY MOUNTING KIT OPTIONS & UPGRADES (ADD OR SUBTRACT GREEN \$ TO PACKAGE PRICE ABOVE FOR TOTAL)

Front Bumper, 1-3/4" round, .095" steel	660-7103B	\$48	\$0	Nose Screen, 1/4" spacing	660-4112	\$50	\$0
Front Bumper, 1-3/4" round, .095" steel W/12" EXT	660-7103C	\$56	+\$8	Nose Screen, black, 1/4" spacing	660-4112-B	\$55	+\$5
Hood Pin Bracket, 3/4" aluminum (SPECIFY MAKE PG 129)	xx0-411A-HPB	\$66	+\$31	Nose Screen, black, 3/16" spacing	660-4111-B	\$55	+\$5
Hood Pin Bracket, 3/4" steel (SPECIFY MAKE PG 129)	xx0-411-HPB	\$35	+\$0	Nose Screen, black aluminum frame, 3/16"	10001-46333B	\$55	+\$5
Hood Pin Kit, 1/2" pins (5PC)	803	\$38	-\$10	Nose Screen, black aluminum frame, 1/4"	10001-46433B	\$55	+\$5
				Universal Body Mounting, aluminum	000-400K	\$49	+\$20

VINYL NOSE & BUMPER COVER GRAPHIC ID KITS FOR A REALISTIC OEM LOOK!

PRINTED ON OUTDOOR DURABLE HIGH-TACK VINYL • GLOSS LAMINATED SURFACE PROVIDES EXCELLENT PROTECTION



CHEVROLET SS

Nose ID Kit 680-410-ID \$39

Bumper Cover ID Kit 680-450-ID \$38

FORD FUSION

Nose ID Kit 500-410-ID \$39

Bumper Cover ID Kit 500-450-ID \$38

TOYOTA CAMRY

Nose ID Kit 740-410-ID \$39

Bumper Cover ID Kit 740-450-ID \$38

DODGE CHARGER

Nose ID Kit 470-410-ID \$39

Bumper Cover ID Kit 470-450-ID \$38

Dodge Charger Nose & Bumper Cover are only available in Black or White

» GO TO PAGES 144-167 TO SEE ALL ACCESSORIES FOR THIS BODY

ORIGINAL ABC BODY STYLES

FEATURED PRODUCTS

ABC LMSC TRUCK PAVMOD OUTLAW LATE MODEL SPORTSMAN OLDER BODIES MD3 LATE MODEL MD3 MODIFIED NORTHEAST MOD STOCK CAR STREET STOCK TA2 PRO STOCK/MOD FUNNY CAR JR RACER WINDOW ACCESSORIES



COWL INDUCTION COLD AIR BOXES:

- » 4 barrel and 2 barrel offset options available
- » Flow bench tested for peak air flow
- » For more details & ordering info, see page 154

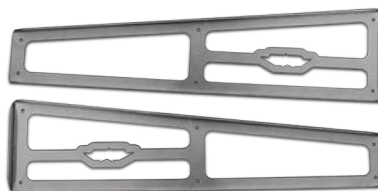

QUARTER PANEL BODY BRACE KIT:

- » Stiffens the quarter panel to maintain correct shape in an aero sensitive area
- » Highly recommend bracing for tracks 1/2-mile and longer
- » Laser-cut aluminum braces have pre-drilled holes for brace attachment
- » For more details & ordering info, see page 162



UNIVERSAL BODY MOUNTING KIT:

- » Universal fit that can be used anywhere on a racecar
- » Plastic kit features Black Delrin washers that withstand repeated impact and stress
- » For more details & ordering info, see page 147



PREMIUM AVEX STYLE RIVETS:

- » Five Star Premium Rivets are known as the best quality on the market
- » Grip range up to 3/16" for 1/8" rivets & up to 1/2" for 3/16" rivets
- » Super-tight grip & won't spin out while drilling!
- » For more details & ordering info, see page 146

» GO TO PAGES 144-167 TO SEE ALL ACCESSORIES FOR THIS BODY STYLE

ORIGINAL ABC

BODY DIMENSIONS

FIVE STAR BODIES ARE DESIGNED TO MAINTAIN PRECISE FIT WITH OPTIMIZED AERODYNAMICS!

WIDTHS

A	B	C
79½" MAX	68"	67"
Body Width: Measured at wheel wells	Door to Door Width: Measured at A-posts & inside edge of doors, measured through car	Door to Door Width: Measured at B-posts & inside edge of doors, measured through car

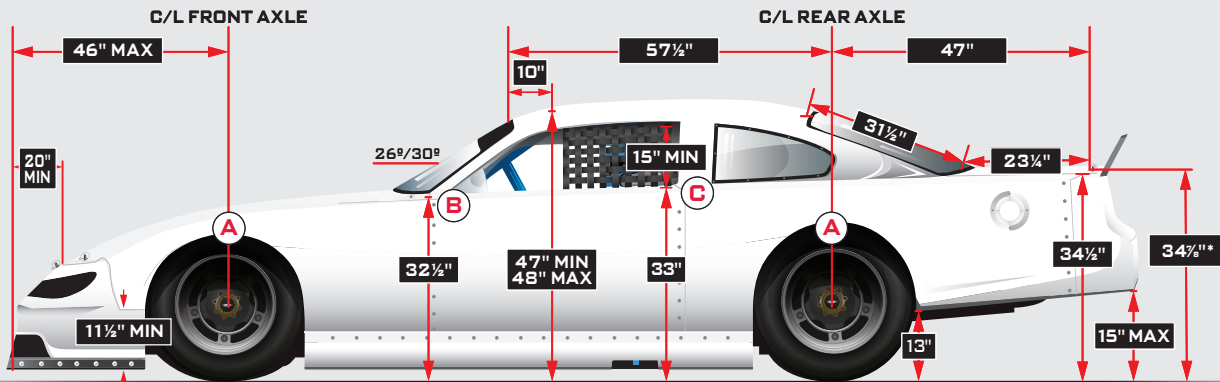

TRADITIONAL ROOF

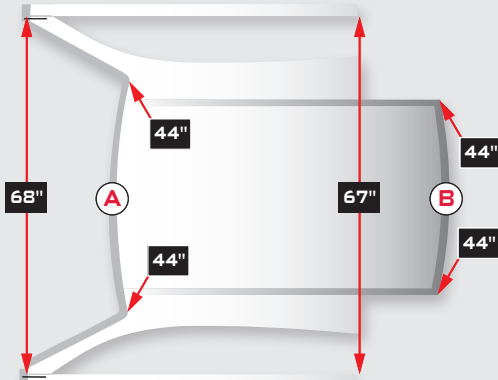

GREENHOUSE

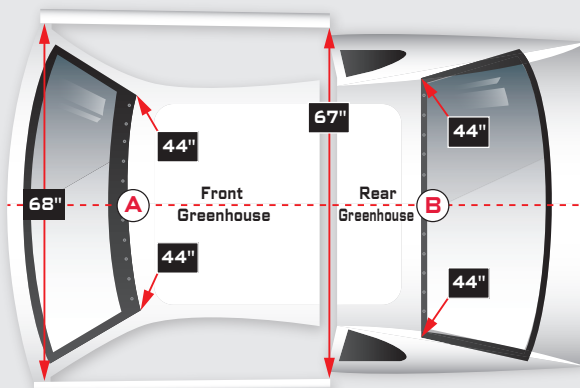

NOTES:

1. If the Roof Height (10" back from windshield), Door Height (rear), Quarter Panel, or Bumper Cover Height dimensions are higher than the stated minimum dimensions, all four must increase by the same amount.
2. Must fit centerline template within allowable tolerance. *Measured at the seam of bumper cover at deck lid intersection, +/-1/4"

CHASSIS	ROOF HEIGHTS	TREAD WIDTH	WHEELBASE
Offset/ Straight Rail	A 47" B 45½"	66" MAX	101-108"

» FOR INDIVIDUAL BODY PANEL DIMENSIONS, VISIT FIVESTARBODIES.COM

THE PERFECT SURFACE PREP FOR PLASTIC

MD3 ADHESION PROMOTER
FAST DRYING & NON-SANDING



MD3 ADHESION PROMOTER

- » Specifically engineered adhesion promoter assures proper paint bonding to our special plastic
- » Other automotive grade primers on the market may not work at all or cause severe paint flaking
- » Improves adhesion of vinyl by enhancing the bond between adhesive on the vinyl and the substrate, for a more durable, long-lasting application
- » Comes in an aerosol spray can for quick and easy application
- » A single can coats approximately 5 individual parts

MD3 Adhesion Promoter	842	\$16
-----------------------	-----	------

» A MUST USE PRODUCT BEFORE PAINTING OR APPLYING VINYL ON ANY FIVE STAR PLASTIC PART

FIVE STAR PLASTIC WINDOW CLEANER

- » This specially formulated anti-static foaming spray contains no chemicals or abrasives that will cause damage to plastic
- » Lifts grease & grime, wipes off fast & easy to provide a streak-free clean & clear surface finish

Window Cleaner, 19oz Can	843	\$9.95
--------------------------	-----	--------

» FIVE STAR CLEANING TIPS!

- » ALWAYS AVOID USING ABRASIVE CLEANERS & CHEMICAL SOLVENTS THAT CAN EASILY CAUSE DAMAGE TO POLYCARBONATE WINDOWS
- » USE A MICROFIBER TOWEL FOR BEST, STREAK-FREE FINISH
- » TO PREVENT SCRATCHING & HAZING ON YOUR WINDOWS, NEVER SCRUB WITH BRUSHES OR ABRASIVE MATERIALS



ORIGINAL ABC BODY STYLES

BODY MOUNTING FIXTURES

MOUNT YOUR BODY FAST & EASY TO MAXIMIZE PERFORMANCE & TO PASS TECH INSPECTION!

It is the responsibility of all competitors to present a car that fits the templates within allowable tolerances and meets all dimensions as inspected by the "Referee." Be sure to download a free copy of the Official ABC Rulebook for body styles, panels, spoilers, windows, over hangs, roof height, proper placement of templates, and more!



THE OFFICIAL REFEREE 2.0

- » Used by tracks and associations throughout North America for body tech inspection
- » Measure the front overhang of the nose, tread width, roof, door, and deck height, rear overhang, wheelbase, and engine setback
- » Adjustable laser option for accurate measurements of front overhang and engine setback
- » Magnetic, tinted polycarbonate wheel plates for better attachment to wheels
- » Includes Tech Inspector's checklist
- » **NOT NECESSARY FOR MOUNTING A BODY.** A body can easily be installed within specs by using the body dimensions sheets & templates

Referee 2.0	TT-200-00	\$2,050
Wheel Locator, with magnets (SET OF 4) (SOLD SEPARATELY)	TT-200-WL	\$98
Laser Measurement Assembly (SOLD SEPARATELY)	TT-200-LB	\$150
Body Centerline Device (SOLD SEPARATELY)	TT-200-BC	\$195

▶ VISIT OUR YOUTUBE PAGE FOR A TECH VIDEO DEMONSTRATING USE OF THE OFFICIAL REFEREE 2.0

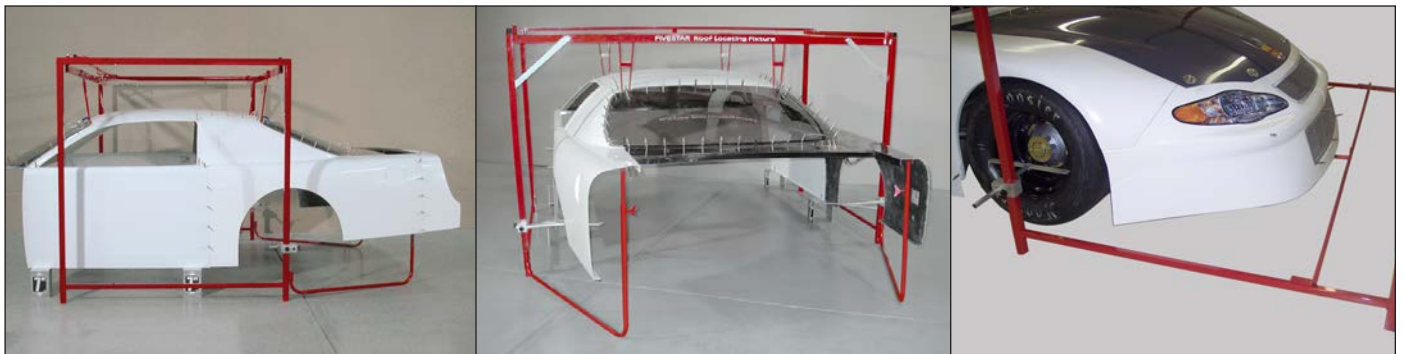

ROOF LOCATING FIXTURE

- » THE FAST & EASY WAY TO MOUNT YOUR COMPLETE BODY WITHOUT THE CHASSIS UNDERNEATH
- » This time-saving device has adjustable quarter panel arms and makes locating the roof on your chassis a simple process
- » Allows exact fit for wheel opening locations, body dimensions, and inspection templates to fit series specs
- » Pre-fits from the cowl to the bumper cover, then can be lifted easily on top of the chassis for final fit
- » Comes in a black powder-coat finish and includes roof brackets, door height blocks and assembly instructions

Roof Locating Fixture (includes Roof Brackets & Door Height Blocks)	809P	\$898
Replacement Roof Brackets	809-1P	\$71
Replacement Door Height Blocks, 7" tall	809-HB	\$38

ORIGINAL ABC BODY STYLES

TOOLS & TEMPLATES



ABC TEMPLATES ENSURE A CORRECT FIT FOR OPTIMUM AERODYNAMICS

- » Complete template set ensures body is installed correctly
- » Complete sets include: Body Centerline, Nose Centerline, Nose Side-to-Side, Fenders, Extended Front Roof Side-to-Side, Extended Rear Roof Side-to-Side, and Rear Deck Side-to-Side
- » Common templates can check all models

Template, Complete Set, wood, Chevrolet SS	660-82	\$444
Template, Complete Set, wood, Ford Fusion	570-82	\$444
Template, Complete Set, wood, Toyota Camry	660-82	\$444
Template, Nose Side-to-Side, wood, Common	XA 672-82NS	\$68
TEMPLATES FOR ENHANCED SHAPE CONTROL		
Template, Roof, Front, Side-to-Side, extended, wood, Common	660-84W	\$75
Template, Roof, Rear, Side-to-Side, extended, wood, Common	660-84S	\$75
Template, Rear Deck Lid, wood, Common	660-84RD	\$75

RULEBOOK



QR CODE

»» DOWNLOAD OFFICIAL ABC RULEBOOK @ FIVESTARBODIES.COM

»» FOR MORE BODY MOUNTING TOOLS, GO TO PAGES 144-167



ENGINEERED THROUGH THE DRIVER'S EYES



NEXTGEN LATE MODEL STOCK

BUILT FOR CHAMPIONS & ENGINEERED FOR VICTORY

This body is the latest advancement in high-performance engineering, raising the bar for durability & aerodynamics in the late model stock division. Designed for hassle-free installation, it delivers the championship-winning edge every racer needs.



- » Enhanced safety with the use of flame-retardant resin in the Ultraglass Composite Greenhouse
- » Exceptional aero balance achieved and validated through extensive wind tunnel & on track testing
- » All panels feature a consistent fit with mounting flanges, locating tabs, and minimal trimming for easy installation and replacement
- » Commonly raced in NASCAR LMSC divisions & CARS Tour Series
- » Two-piece greenhouse includes a built-in cowl & deck lid filler
- » Common body has 3 nose options for brand identity
- » Designed to fit perimeter-style chassis
- » Available in 4 color options



CONNECT WITH TEAM FIVE STAR | FIVESTARBODIES.COM    

LATE MODEL STOCK

BODY PANELS & OPTIONS

HOW TO ORDER YOUR BODY IN 3 QUICK & EASY STEPS

» 1. SELECT BODY PACKAGE » 2. SELECT PANEL COLOR » 3. SELECT NOSE MAKE

RE-SKIN BODY PACKAGE		-W -B	-CB -R
Bumper Cover, Rear, high-impact plastic	11002-45051-x	\$155	\$160
Door, aluminum, left	13002-21033-xL	\$112	\$112
Door, aluminum, right	13002-21033-xR	\$112	\$112
Fender, high-impact plastic, left	11002-23051-xL	\$150	\$154
Fender, high-impact plastic, right	13002-23051-xR	\$150	\$154
Nose, high-impact plastic (SPECIFY MAKE: CAMARO-11132; MUSTANG-11322; CAMRY-11712)	11xxx-41051-x	\$164	\$171
Quarter Panel, Ultraglass composite, left	13002-27313-xL	\$326	\$382
Quarter Panel, Ultraglass composite, right	13002-27313-xR	\$326	\$382
Rocker Panel, fits either side, high-impact plastic (2 REQUIRED) SPECIFY COLOR: -W -B -CB -R	000-5501P-x	\$33	\$38
Rocker Panel, fits either side, high-impact plastic (ENTERED TWICE TO SHOW PACKAGE PRICE)	000-5501P-x	\$33	\$38
RE-SKIN BODY PACKAGE PRICE	13002-10000-x	\$1,561	\$1,703

COMPLETE BODY PACKAGE (RE-SKIN COMPONENTS PLUS ITEMS BELOW)		-W -B	-CB -R
Deck Lid Hold-Down Strip, aluminum	XM 000-310H-x	\$10	\$10
Deck Lid, aluminum	661-310A-x	\$76	\$76
Greenhouse, Front, Ultraglass composite with fire retardant resin	13002-51313-x	\$755	\$799
Greenhouse, Rear, Ultraglass composite with fire retardant resin	13002-51513-x	\$743	\$799
Hood, oversized, composite	11002-33011-x	\$320	\$360
Spoiler, Complete, 2pc, unpainted aluminum blades, 5" x 64.5", 55°	13002-47555	\$115	\$115
Windshield, mar-resistant coated, 1/8"	13002-63253	\$377	\$377
Window, Quarter, mar-resistant coated, 0.093", left	11002-65153-L	\$65	\$65
Window, Quarter, mar-resistant coated, 0.093", right	11002-65153-R	\$65	\$65
Window, Rear, uncoated, 0.093"	11002-61151	\$201	\$201
COMPLETE BODY PACKAGE PRICE	13002-10600-x	\$4,288	\$4,570

*ALL WINDOWS ARE PRECUT TO FIT, BEVELED & DRILLED, WITH BLACK-OUT BORDER UNLESS OTHERWISE SPECIFIED.

TO ENHANCE YOUR BODY PACKAGE, CHOOSE FROM THE OPTIONS BELOW:

BODY PACKAGE OPTIONS & UPGRADES (ADD OR SUBTRACT GREEN \$ FROM PACKAGE PRICE ABOVE FOR TOTAL)		-W -B	+/- PKG PRICE	-CB -R	+/- PKG PRICE
Door, with fender mounting recess, aluminum, left / right (BODY PKG PRICE IS X2)	13002-21233-xLorR	\$112	\$0	\$112	\$0
Door, for longer wheelbase, aluminum, left / right (SPECIAL ORDER) (BODY PKG PRICE IS X2)	13002-21133-xLorR	\$112	\$0	\$112	\$0
Fender, Ultraglass composite, left	11002-23013-xL	\$295	+\$145	\$325	+\$171
Fender, Ultraglass composite, right	13002-23013-xR	\$295	+\$145	\$325	+\$171
Rocker Panels, fits either side, aluminum (BODY PKG PRICE IS X2)	000-5501A-x	\$39	+\$6	\$39	+\$1
Hood, oversized, advanced lightweight composite	11002-33011L-x	\$619	+\$299	\$619	+\$259
Spoiler, Complete, 2pc, black aluminum blades & brackets, 5" x 64.5", 55°	13002-47555-B	\$125	+\$10	\$125	+\$10
Spoiler, Complete, 4pc, 3/16" poly blades, unpainted aluminum brackets, 5" x 64.5", 55°	13002-47355	\$129	+\$14	\$129	+\$14
Spoiler, Complete, 4pc, 3/16" poly blades, black aluminum brackets, 5" x 64.5", 55°	13002-47355-B	\$139	+\$24	\$139	+\$24
Window, Rear, mar-resistant coated, .093"	11002-61153	\$347	+\$146	\$347	+\$146
Windshield, mar-resistant coated, 3/16" (FOR ENHANCED DRIVER SAFETY)	13002-63353	\$427	+\$50	\$427	+\$50



LATE MODEL STOCK

BODY MOUNTING KIT

» EVERYTHING YOU NEED FOR THAT CLEAN & PROFESSIONAL INSTALL!

COMPLETE BODY MOUNTING KIT SAVE \$\$ WHEN PURCHASING COMPLETE KIT VERSUS INDIVIDUAL COMPONENTS!

Adjustable Body Braces (X3 @ \$35EA)	807-3	\$105
Aluminum Nose Side Braces, pair	11002-75333	\$15
Door Vent Windows, pair	11002-66222	\$38
Front Bumper Mounting Kit	10001-72721	\$132
Front Bumper, 1-3/4", .065" steel	13002-71182	\$48
Graphics, Nose ID Kit (SPECIFY MAKE BELOW)	11xx2-44141	\$39
Graphics, Bumper Cover ID Kit (SPECIFY MAKE BELOW)	11xx2-44541	\$38
Hood Pin Bracket, 3/4" steel (4 PINS REQUIRED)	11002-34331	\$35
Hood Pin Kit, 3/8" pins (X2 @ \$16EA) SPECIFY COLOR: -B -CB -R	10001-34033-x	\$32
Nose Screen, stainless, 3/16"	660-4111	\$50
Rear Bumper Mounting Kit	802-25	\$49
Rear Bumper, 1-3/4", .065" steel	11002-71682	\$48
Rear Deck Mounting Kit	660-450-RDK	\$89
Rear Window Brace Kit (3PC)	11002-76133	\$84
Universal Body Mounting, plastic	00001-72651	\$29
Wear Strips, plastic SPECIFY COLOR: -W -B -CB -OR -R -Y -FG -FO -FR -FY	11002-41551-x	\$35
Window Installation Kit	805	\$27
Windshield Brace Kit (3PC)	13002-76333	\$84
COMPLETE KIT PRICE WITH 10% DISCOUNT 13002-72520		\$879.30

BODY MOUNTING KIT OPTIONS & UPGRADES (ADD OR SUBTRACT GREEN \$ FROM COMPLETE KIT PRICE ABOVE FOR TOTAL)

Front Bumper, 1-3/4" round, .095" steel	13002-71185	\$48	\$0	Nose Screen, black, 1/4" spacing	660-4112-B	\$55	+\$5
Front Bumper, 1-3/4" round, .095" steel W/ 12" EXT.	13002-71188	\$56	+\$8	Nose Screen, black, 3/16" spacing	660-4111-B	\$55	+\$5
Hood Pin Bracket, 3/4" aluminum	11002-34333	\$66	+\$31	Nose Screen, black aluminum frame, 3/16"	10001-46333B	\$55	+\$5
Hood Pin Kit, 1/2" pins (5pc)	803	\$38	+\$6	Nose Screen, black aluminum frame, 1/4"	10001-46433B	\$55	+\$5
Nose Screen, 1/4" spacing	660-4112	\$50	\$0	Universal Body Mounting, aluminum	000-400K	\$49	+\$20

VINYL NOSE & BUMPER COVER GRAPHIC ID KITS FOR A REALISTIC OEM LOOK!

Printed on outdoor durable high-tack vinyl • Gloss laminated surface provides excellent protection



CHEVROLET CAMARO

Nose ID Kit	11132-44141	\$39
Bumper Cover ID Kit	11132-44542	\$38

FORD MUSTANG

Nose ID Kit	11322-44141	\$39
Bumper Cover ID Kit	11322-44541	\$38

TOYOTA CAMRY

Nose ID Kit	11712-44141	\$39
Bumper Cover ID Kit	11712-44541	\$38

» GO TO PAGES 144-167 TO SEE ALL ACCESSORIES FOR THIS BODY

PRICING SUBJECT TO CHANGE WITHOUT NOTICE

LATE MODEL STOCK

FEATURED BODY ACCESSORIES

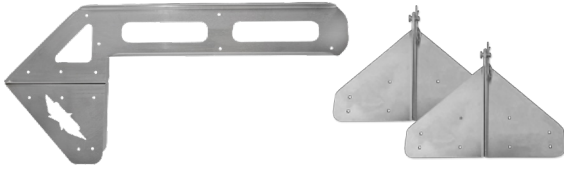

ALUMINUM HOOD HINGE KITS:

- » Hinged hoods create easy access to the engine compartment
- » Long and Short Hood Hinge Kit options include laser-cut aluminum hinge, pin, and clip assembly.
- » For more details & ordering info, see page 151



QUARTER PANEL BODY BRACE KIT:

- » Stiffens the quarter panel to maintain correct shape in an aero sensitive area
- » Highly recommend bracing for tracks 1/2-mile and longer
- » Laser-cut aluminum braces have pre-drilled holes for brace attachment
- » For more details & ordering info, see page 162

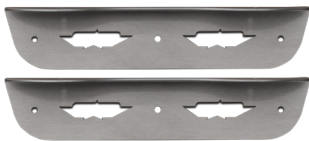

ALUMINUM NOSE SIDE BRACES:

- » Provides structure to an aero critical part of the car
- » Laser-cut aluminum is pre-drilled for riveting to the nose and for mounting body braces
- » For more details & ordering info, see page 150



PREMIUM AVEX STYLE RIVETS:

- » Five Star Premium Rivets are known as the best quality on the market
- » Grip range up to 3/16" for 1/8" rivets & up to 1/2" for 3/16" rivets
- » Super-tight grip & won't spin out while drilling!
- » For more details & ordering info, see page 146

» GO TO PAGES 144-167 TO SEE ALL ACCESSORIES FOR THIS BODY STYLE

LATE MODEL STOCK

BODY DIMENSIONS

FIVE STAR BODIES ARE DESIGNED TO MAINTAIN PRECISE FIT WITH OPTIMIZED AERODYNAMICS!

WIDTHS

A	B
67"	65½"

Door to Door Width: Measured at A-posts & inside edge of doors, measured through car

Door to Door Width: Measured at B-posts & inside edge of doors, measured through car

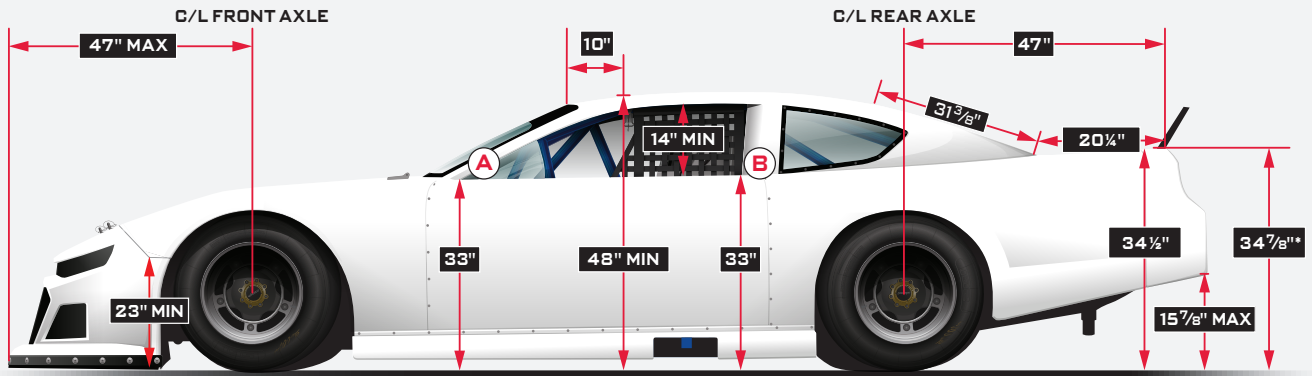

NOTES:

1. If the Roof Height (10" back from windshield), Door Height (rear), Quarter Panel, or Bumper Cover Height dimensions are higher than the stated minimum dimensions, all four must increase by the same amount.

2. Must fit centerline template within allowable tolerance. *Measured at the seam of bumper cover at deck lid intersection, +/- 1/4"

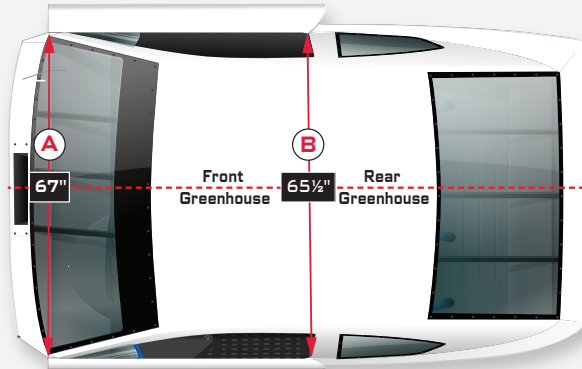

CHASSIS	ROOF HEIGHT	TREAD WIDTH	WHEELBASE
LMSC Perimeter	48"	Up to 64½"	Up to 106"

SCAN HERE TO



SHOP ONLINE

» FOR INDIVIDUAL BODY PANEL DIMENSIONS, VISIT FIVESTARBODIES.COM

PRICING SUBJECT TO CHANGE WITHOUT NOTICE

LATE MODEL STOCK

BODY MOUNTING FIXTURES

MOUNT YOUR BODY FAST & EASY TO MAXIMIZE PERFORMANCE & TO PASS TECH INSPECTION!

It is the responsibility of all competitors to present a car that fits the templates within allowable tolerances and meets all dimensions as inspected by the "Referee." Be sure to download a free copy of the Official ABC Rulebook for body styles, panels, spoilers, windows, over hangs, roof height, proper placement of templates, and more!



THE OFFICIAL REFEREE 2.0

- » Used by tracks and associations throughout North America for body tech inspection
- » Measure the front overhang of the nose, tread width, roof, door, and deck height, rear overhang, wheelbase, and engine setback
- » Adjustable laser option for accurate measurements of front overhang and engine setback
- » Magnetic, tinted polycarbonate wheel plates for better attachment to wheels
- » Includes Tech Inspector's checklist
- » **NOT NECESSARY FOR MOUNTING A BODY.** A body can easily be installed within specs by using the body dimensions sheets & templates

Referee 2.0	TT-200-00	\$2,050
Wheel Locator, w/magnets (SET OF 4) (SOLD SEPARATELY)	TT-200-WL	\$98
Laser Measurement Assembly (SOLD SEPARATELY)	TT-200-LB	\$150
Body Centerline Device (SOLD SEPARATELY)	TT-200-BC	\$195

▶ VISIT OUR YOUTUBE PAGE FOR A TECH VIDEO DEMONSTRATING USE OF THE OFFICIAL REFEREE 2.0

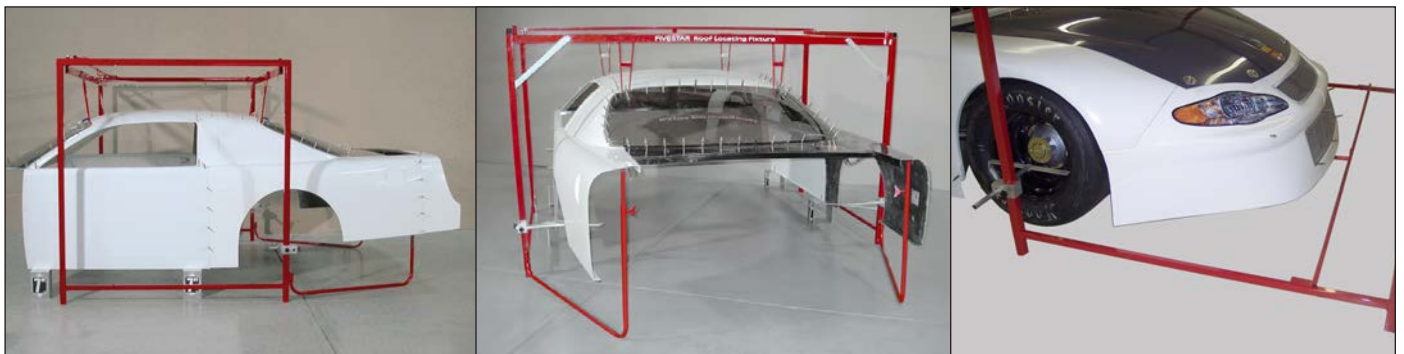

ROOF LOCATING FIXTURE

- » THE FAST & EASY WAY TO MOUNT YOUR COMPLETE BODY WITHOUT THE CHASSIS UNDERNEATH
- » This time-saving device has adjustable quarter panel arms and makes locating the roof on your chassis a simple process
- » Allows exact fit for wheel opening locations, body dimensions, and inspection templates to fit series specs
- » Pre-fits from the cowl to the bumper cover, then can be lifted easily on top of the chassis for final fit
- » Comes in a black powder-coat finish and includes roof brackets, door height blocks and assembly instructions

Roof Locating Fixture (INCLUDES ROOF BRACKETS & DOOR HEIGHT BLOCKS)	809P	\$898
Replacement Roof Brackets	13002-72231	\$71
Replacement Door Height Blocks, 6" tall	11002-72331	\$38

LATE MODEL STOCK

TOOLS & TEMPLATES



LATE MODEL STOCK TEMPLATES ENSURE A CORRECT FIT FOR OPTIMUM AERODYNAMICS

- » Complete template set ensures body is installed correctly
- » Complete sets include: Body Centerline, Fenders, Nose Centerline, Nose Side-to-Side, Front & Rear Roof Side-to-Side
- » Nose and fender templates are specific to model
- » Common templates can check all models
- » Master sets available with templates for all models

Template, Complete Set, wood, Chevrolet Camaro	13132-82091	\$278
Template, Complete Set, wood, Ford Mustang	13322-82091	\$278
Template, Complete Set, wood, Toyota Camry	13712-82091	\$278
Template, Master Set, wood, all models	13002-82091	\$432

» FOR MORE BODY MOUNTING TOOLS, GO TO PAGES 144-167



» DOWNLOAD OFFICIAL LMSC RULEBOOK @ FIVESTARBODIES.COM



ENGINEERED THROUGH THE DRIVER'S EYES



SHORT TRACK TRUCK

SETTING THE STANDARD FOR PEAK PERFORMANCE

As the top choice for many Truck Series across the country, this body style is engineered for superior performance & unmatched quality.

Elevate your racing experience with a bold design that not only impresses, but gives you the winning edge on every lap.





- » Common body uses different upper noses for brand identity: Chevy, Ford, Toyota, Dodge
- » Easy to install roof has a built-in cowl & windshield base
- » 4-piece nose for quick & easy replacement
- » Fits 8" & 10" tires
- » Available in 2 color options



SHORT TRACK TRUCK

BODY PANELS & OPTIONS

HOW TO ORDER YOUR BODY IN 3 QUICK & EASY STEPS

» 1. SELECT BODY PACKAGE » 2. SELECT PANEL COLOR » 3. SELECT NOSE MAKE

RE-SKIN BODY PACKAGE

-W -B

Bumper Cover, Rear, high-impact plastic	21001-45051-x	\$162
Door, aluminum, left	21001-21033-xL	\$116
Door, aluminum, right	21001-21033-xR	\$116
Fender, high-impact plastic, left	21001-23051-xL	\$156
Fender, high-impact plastic, right	21001-23051-xR	\$156
Nose, Lower, high-impact plastic	81001-41151-x	\$155
Nose, Upper, high-impact plastic (SPECIFY MAKE: SILVERADO-21191; F-150-21341; RAM/TUNDRA-21721)	21x1-41051-x	\$117
Bed Side, aluminum, left	21001-27333-xL	\$166
Bed Side aluminum, right	21001-27333-xR	\$166
Rocker Panel, fits either side, high-impact plastic (2 REQUIRED) SPECIFY COLOR: -W -B -CB -R	000-5501P-x	\$33
Rocker Panel, fits either side, high-impact plastic (ENTERED TWICE TO SHOW PACKAGE PRICE)	000-5501P-x	\$33
RE-SKIN BODY PACKAGE PRICE	21001-10000-x	\$1,376

COMPLETE BODY PACKAGE (RE-SKIN COMPONENTS PLUS ITEMS BELOW)

-W -B

Bed Cover #1, Front Section, aluminum	T000-351A-x	\$78
Bed Cover #2, Center Section, aluminum	T000-352A-x	\$142
Bed Cover #3, Rear Section, aluminum	T000-353A-x	\$78
Greenhouse, Front, composite	21001-51311-x	\$535
Greenhouse, Rear, composite	21001-51511-x	\$296
Hood, composite	21001-33011-x	\$320
Rear Cab Filler Panel, aluminum	T220-3200-x	\$52
Cowl Air Insert, composite	661-5100A-x	\$72
Spoiler, 1pc, .080" aluminum, 5" x 60"	000-6702	\$40
Window, Rear, uncoated, .093 (REQUIRES TRIMMING, PRECUT TO FIT ON BOTTOM ONLY)	21001-61151	\$75
Windshield, mar-resistant coated, w/ blackout border, 1/8"	21001-63253	\$355
COMPLETE BODY PACKAGE PRICE	21001-10600-x	\$3,419

TO ENHANCE YOUR BODY PACKAGE, CHOOSE FROM THE OPTIONS BELOW:

BODY PACKAGE OPTIONS & UPGRADES (ADD OR SUBTRACT TO PACKAGE PRICE ABOVE FOR TOTAL)

-W -B

+/- PKG PRICE

Rocker Panels, fits either side, aluminum (2 REQUIRED) SPECIFY COLOR: -W -B -CB -R	000-5501A-x	\$39	+\$6
Spoiler, 1pc, .080 aluminum, 5" X 65"	T000-6702	\$40	\$0
Spoiler, 1pc, 1/8" polycarbonate, 5" x 60"	000-6701	\$40	\$0
Window, Rear, mar-resistant coated, .093	21001-61153	\$131	+\$56



FOR OLDER SHORT TRACK TRUCK BODY PANELS & OPTIONS, VISIT OUR WEBSITE!

SHORT TRACK TRUCK

BODY MOUNTING KIT

» EVERYTHING YOU NEED FOR THAT CLEAN & PROFESSIONAL INSTALL!

COMPLETE BODY MOUNTING KIT SAVE \$\$ WHEN PURCHASING COMPLETE KIT VERSUS INDIVIDUAL COMPONENTS!

Adjustable Body Braces (X3 @ \$35EA)	807-3	\$105
Aluminum Nose Side Braces, pair	11002-75333	\$15
Front Bumper Mounting Kit	10001-72721	\$132
Front Bumper, 1-1/2", .065" steel	21001-71162	\$48
Graphics, Nose ID Kit (SPECIFY MAKE BELOW)	21xx1-44141	\$39
Graphics, Bumper Cover ID Kit (SPECIFY MAKE BELOW)	21xx1-44541	\$38
Hood Pin Bracket, 1/2" steel (4 PINS REQUIRED)	21001-34131	\$35
Hood Pin Kit, 3/8" pins (X2 @ \$15EA) SPECIFY COLOR: -B -CB -R	10001-34033-x	\$16
Nose Screen, black, 1/4"	81001-46433B	\$55
Rear Bumper Mounting Kit	802-25	\$49
Rear Bumper, 1-3/4", .065" steel	T000-7503	\$48
Right Side Door Support	11002-75533	\$30
Window Installation Kit	805	\$27
Windshield Brace Kit (3PD)	21001-76333	\$84
COMPLETE KIT PRICE WITH 10% DISCOUNT	21001-72521	\$649

VINYL NOSE & BUMPER COVER GRAPHIC ID KITS FOR A REALISTIC OEM LOOK!

PRINTED ON OUTDOOR DURABLE HIGH-TACK VINYL • GLOSS LAMINATED SURFACE PROVIDES EXCELLENT PROTECTION



CHEVROLET SILVERADO

Nose ID Kit	21191-44141	\$39
Bumper Cover ID Kit	21191-44541	\$38



FORD F-150

Nose ID Kit	21341-44141	\$39
Bumper Cover ID Kit	21341-44541	\$38



DODGE RAM

Nose ID Kit	21591-44141	\$39
Bumper Cover ID Kit	21591-44541	\$38



TOYOTA TUNDRA

Nose ID Kit	21721-44141	\$39
Bumper Cover ID Kit	21721-44541	\$38

» GO TO PAGES 144-167 TO SEE ALL ACCESSORIES FOR THIS BODY

PRICING SUBJECT TO CHANGE WITHOUT NOTICE

SHORT TRACK TRUCK

FEATURED BODY ACCESSORIES



ALUMINUM HOOD HINGE KITS:

- » Hinged hoods create easy access to the engine compartment
- » Long and Short Hood Hinge Kit options include Laser cut aluminum hinge, pin, and clip assembly.
- » For more details & ordering info, see page 151

PREMIUM AVEX STYLE RIVETS:

- » Five Star Premium Rivets are known as the best quality on the market
- » Grip range up to 3/16" for 1/8" rivets & up to 1/2" for 3/16" rivets
- » Super-tight grip & won't spin out while drilling!
- » For more details & ordering info, see page 146

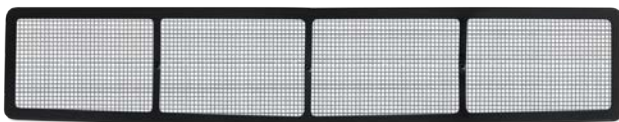

LOWER NOSE SCREEN

- » Protects the radiator from debris penetration
- » Frame is laser cut from lightweight aluminum
- » Screen is high strength stainless steel (1/4" MESH IS WELDED)
- » Durable black powder-coated finish
- » Weighs only 10.32oz

Nose Screen, common	81001-464338	\$55
---------------------	--------------	------



CHASSIS CLAMPS:

- » Universal mount fits anywhere bracing is needed
- » Eliminate the need for welding or use of hose clamps when mounting body braces
- » Ideal for use with all Five Star's Adjustable Body Braces
- » For more details & ordering info, see page 165

» GO TO PAGES 144-167 TO SEE ALL ACCESSORIES FOR THIS BODY STYLE

SHORT TRACK TRUCK

BODY DIMENSIONS & TEMPLATES

FIVE STAR BODIES ARE DESIGNED TO MAINTAIN PRECISE FIT WITH OPTIMIZED AERODYNAMICS!

Make sure your body fits our template package and dimension specs to maximize performance and to pass tech inspection!

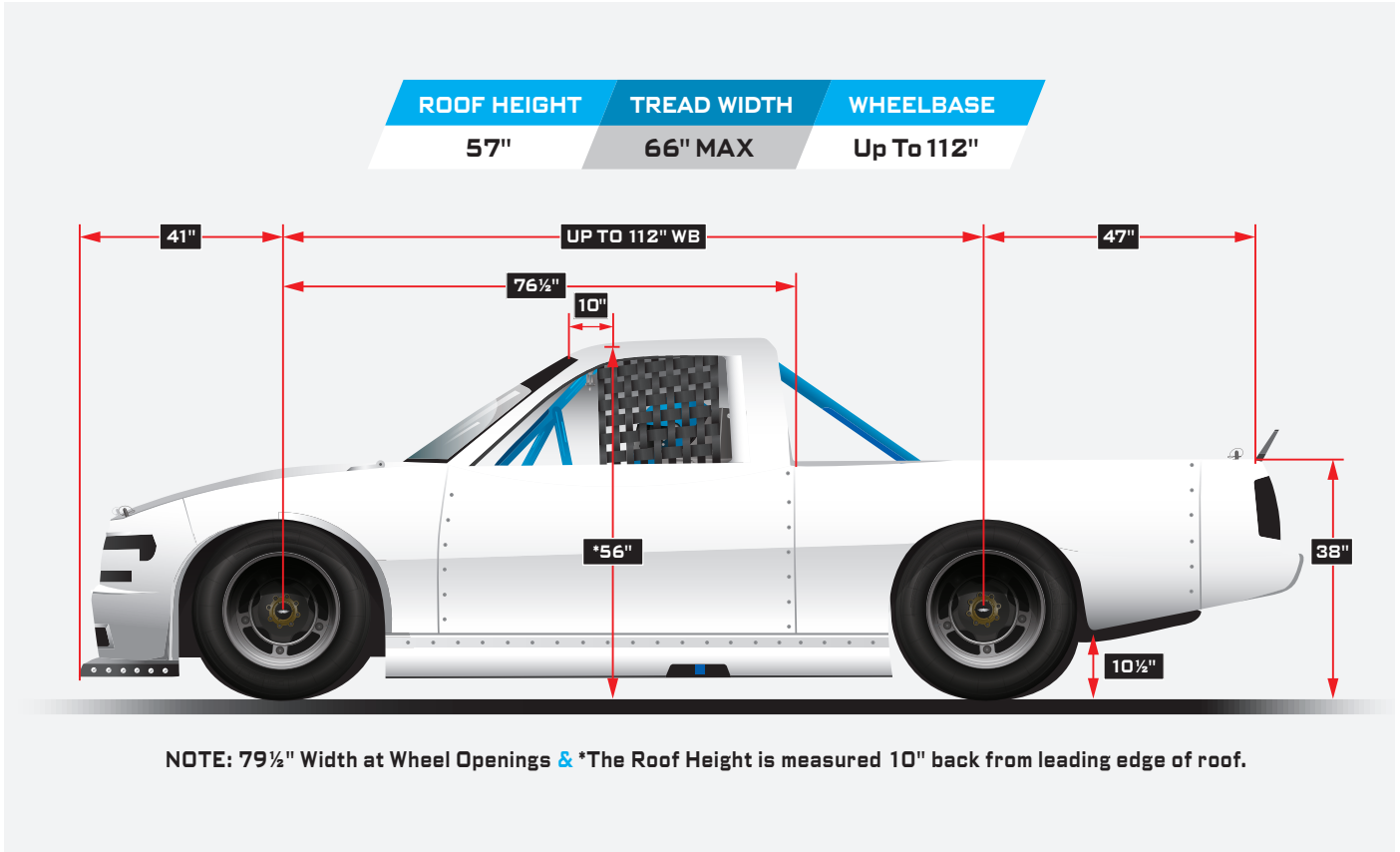

SHORT TRACK TRUCK TEMPLATES ENSURE A CORRECT FIT FOR OPTIMUM AERODYNAMICS

- » Complete template set ensures body is installed correctly
- » Complete sets include: Body Centerline, Nose Centerline, & Rear Roof Side-to-Side
- » Common templates can check all models

Template, Complete Set, aluminum, common	21001-82033	\$339
Template, Complete Set, wood, common	21001-82091	\$94

» FOR MORE BODY MOUNTING TOOLS, GO TO PAGES 144-167



» FOR INDIVIDUAL BODY PANEL DIMENSIONS, VISIT FIVESTARBODIES.COM

PRICING SUBJECT TO CHANGE WITHOUT NOTICE

ENGINEERED THROUGH THE DRIVER'S EYES



PAVEMENT MODIFIED

THE ULTIMATE IN AERODYNAMIC DESIGN

This body is equipped with an aerodynamically advanced roof featuring built-in vortex generators, engineered to optimize airflow for peak performance. In addition to its high-performance design, this body is ready to fit almost any short track modified chassis & is approved for all major modified series.



- » Rear wheel flares enhance aerodynamics & add rigidity to the side while protecting the tires from being cut
- » This roof has a built in cowl panel & separate rear window mounting flange
- » Roof features built in vortex generators to enhance airflow
- » Repeatable fit for all replacement panels
- » Fits most short track modified chassis
- » Roof design is the easiest to install
- » Legal in all major modified series
- » Panels available in 4 color options



PAVEMENT MODIFIED

BODY PANELS & OPTIONS

HOW TO ORDER YOUR BODY IN 3 QUICK & EASY STEPS

» 1. SELECT BODY PACKAGE » 2. SELECT PANEL COLOR » 3. SELECT NOSE MAKE

COMPLETE BODY PACKAGE	GAMARO	MUSTANG	-W -B	-CB -R	-FG -FO -FR -FY
Door, aluminum, left	020-21A-xL	020-21A-xL	\$112	\$112	N/A
Door, aluminum, right	020-21A-xR	020-21A-xR	\$112	\$112	N/A
Hood, center, aluminum	020-33AC-x	020-33AC-x	\$112	\$112	N/A
Hood, side, composite, left	020-330-xL	020-330-xL	\$115	\$145	N/A
Hood, side, composite, right	020-330-xR	020-330-xR	\$115	\$145	N/A
Nose, high-impact plastic, center (ALSO AVAILABLE IN ORANGE)	020-410-xC	020-410-xC	\$52	\$52	N/A
Nose, high-impact plastic, left (ALSO AVAILABLE IN ORANGE)	020-410-xL	020-410-xL	\$87	\$87	N/A
Nose, high-impact plastic, right (ALSO AVAILABLE IN ORANGE)	020-410-xR	020-410-xR	\$87	\$87	N/A
Nose Filler Panel, aluminum	020-4101A-x	020-4101A-x	\$35	\$35	N/A
Quarter Panel, aluminum, left	020-27A-xL	020-27A-xL	\$123	\$123	N/A
Quarter Panel, aluminum, right	020-27A-xR	020-27A-xR	\$123	\$123	N/A
Rear Filler Panel, aluminum	020-450A-x	020-450A-x	\$38	\$38	N/A
Roof, composite	022-5102-x	025-5102-x	\$523	\$560	N/A
Sail Panel, composite, left	022-280-xL	025-280-xL	\$85	\$96	N/A
Sail Panel, composite, right	022-280-xR	025-280-xR	\$85	\$96	N/A
Rocker Panel, high-impact plastic (x3 at \$43 each) (ALSO AVAILABLE IN ORANGE)	007-5500-x	007-5500-x	\$40	\$40	\$46
Spoiler, 1pc, 1/8" polycarbonate, up to 8"	000-6701	000-6701	\$40	\$40	N/A
Wheel Flares, 3pc, high-impact plastic, left side (ALSO AVAILABLE IN ORANGE)	007-261-xL	007-261-xL	\$54	\$54	\$67
Wheel Flares, 3pc, high-impact plastic, right side (ALSO AVAILABLE IN ORANGE)	007-261-xR	007-261-xR	\$54	\$54	\$67
Hood Scoop, composite	020-3330-x	020-3330-x	\$85	\$98	N/A
Window, Rear, flat, oversized, mar-resistant coated, 0.093"	020-6105-1	020-6105-1	\$130	\$130	N/A
Windows, Quarter, mar-resistant coated, 0.093", pair	022-6505B	025-6505B	\$109	\$109	N/A
Windshield, molded, mar-resistant coated, 1/8"	020-6325-2B	020-6325-2B	\$294	\$294	N/A
COMPLETE BODY PACKAGE PRICE	022-132-x	025-132-x	\$2,610	\$2,742	

*All windows are precut to fit, beveled & drilled, with black-out border unless otherwise specified.

TO ENHANCE YOUR BODY PACKAGE, CHOOSE FROM THE OPTIONS BELOW:

BODY PACKAGE OPTIONS & UPGRADES (ADD OR SUBTRACT TO PACKAGE PRICE ABOVE FOR TOTAL)		+/- PKG PRICE
Window, Rear, molded, oversized, mar-resistant coated, 0.093"	020-6115-1	\$159 \$29
Spoiler, 1-piece .080" aluminum, up to 8"	000-6702	\$40 \$0



» FOR INDIVIDUAL BODY PANEL DIMENSIONS VISIT FIVESTARBODIES.COM

PAVEMENT MODIFIED

FEATURED BODY ACCESSORIES



PREMIUM AVEX STYLE RIVETS:

- » Five Star Premium Rivets are known as the best quality on the market
- » Grip range up to 3/16" for 1/8" rivets & up to 1/2" for 3/16" rivets
- » Super-tight grip & won't spin out while drilling!
- » For more details & ordering info, see page 146



CHASSIS CLAMPS:

- » Universal mount fits anywhere bracing is needed
- » Eliminate the need for welding or use of hose clamps when mounting body braces
- » Threaded flange / no nut required
- » Three options to fit different roll bar tubing thickness
- » For more details & ordering info, see page 165



WIDE ANGLE RACING MIRROR:

- » This convex glass mirror gives you the best view of your competition!
- » All black frame with black anodized machined aluminum brackets
- » For more details & ordering info, see page 166

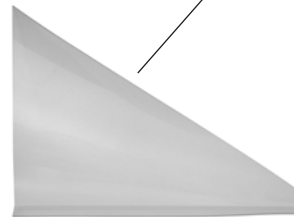

POLYCARBONATE DOOR VENT WINDOWS:

- » Molded vent windows give cars a proven performance gain in the wind tunnel over flat unmolded windows
- » Oversized and cut-to-fit options made of molded, mar-resistant coated clear .093" polycarbonate
- » For more details & ordering info, see page 166

» GO TO PAGES 144-167 TO SEE ALL ACCESSORIES FOR THIS BODY STYLE

PRICING SUBJECT TO CHANGE WITHOUT NOTICE

ENGINEERED THROUGH THE DRIVER'S EYES



OUTLAW LATE MODEL

ENGINEERED TO ACHIEVE MAXIMUM DOWNFORCE

The Outlaw Late Model Nose lives in Victory Lane! With unmatched downforce, effortless installation & our ultra-durable proprietary plastic blend, racers agree—this nose outperforms all others on the market!





OUTLAW NOSE FEATURES:

- » 1-piece center can be cut for nose width adjustability
- » Aggressive aero styling for maximum downforce
- » Nose screen recess molded into the center
- » Fenders allow for maximum tire clearance
- » Fits flat to hood & rear fender area
- » Height adjustable lower fender
- » 3-1/2" wide built-in valance
- » Nose and fenders available in 5 colors



OUTLAW LATE MODEL

BODY PANELS & OPTIONS

OUTLAW NOSE COMBO KIT

-W -B -CB -R -G

Nose, high-impact plastic (VINYL GRAPHIC KIT INCLUDED)	22001-41051-X	\$61
Fender, upper, high-impact plastic, left	22001-23251-XL	\$71
Fender, upper, high-impact plastic, right	22001-23251-XR	\$71
Fender, lower, high-impact plastic, left	22001-23351-XL	\$28
Fender, lower, high-impact plastic, right	22001-23351-XR	\$28
NOSE COMBO KIT PRICE		\$259

COMMON BODY PANELS & WINDOWS

-W -B

-CB -R -G

-FG -FO -FR -FY

Nose Support, Lower, high-impact plastic	22001-42351	\$110	N/A	N/A
Nose Filler Panel, high-impact plastic	32000-35851-x	\$128	\$128	N/A
Nose Screen, 3/16" spacing	22001-46333	\$50	N/A	N/A
Nose Screen, black, 3/16" spacing	22001-46333B	\$55	N/A	N/A
Rocker Panel, high-impact plastic (3 NEEDED FOR COMPLETE INSTALL)	007-5500-X	\$40	\$40	\$46
Roof Option #1 (CHOOSE STANDARD COMPOSITE OR ADVANCED LIGHTWEIGHT COMPOSITE)				
Roof, composite	22001-51211-x	\$295	N/A	N/A
Roof, advanced lightweight composite	22001-51212-x	\$495	N/A	N/A
Roof Option #2 (WORKS WITH SAIL PANELS)				
Roof, Pavement Modified, composite	022-5102-x	\$523	\$560	N/A
Sail Panel, composite, left/right	022-280-XLorR	\$85	\$96	N/A
Window, Rear, .093", flat, mar-resistant coated, oversize	020-6105-1	\$130	\$130	N/A
Window, Quarter, Camaro, .093", mar-resistant coated, pre-cut to fit, pair	022-6505B	\$109	\$109	N/A
Windshield, 1/8", molded, mar-resistant coated, pre-cut to fit	020-6325-2B	\$294	\$294	N/A

*ALL WINDOWS ARE PRECUT TO FIT, BEVELED & DRILLED, WITH BLACK-OUT BORDER UNLESS OTHERWISE SPECIFIED.

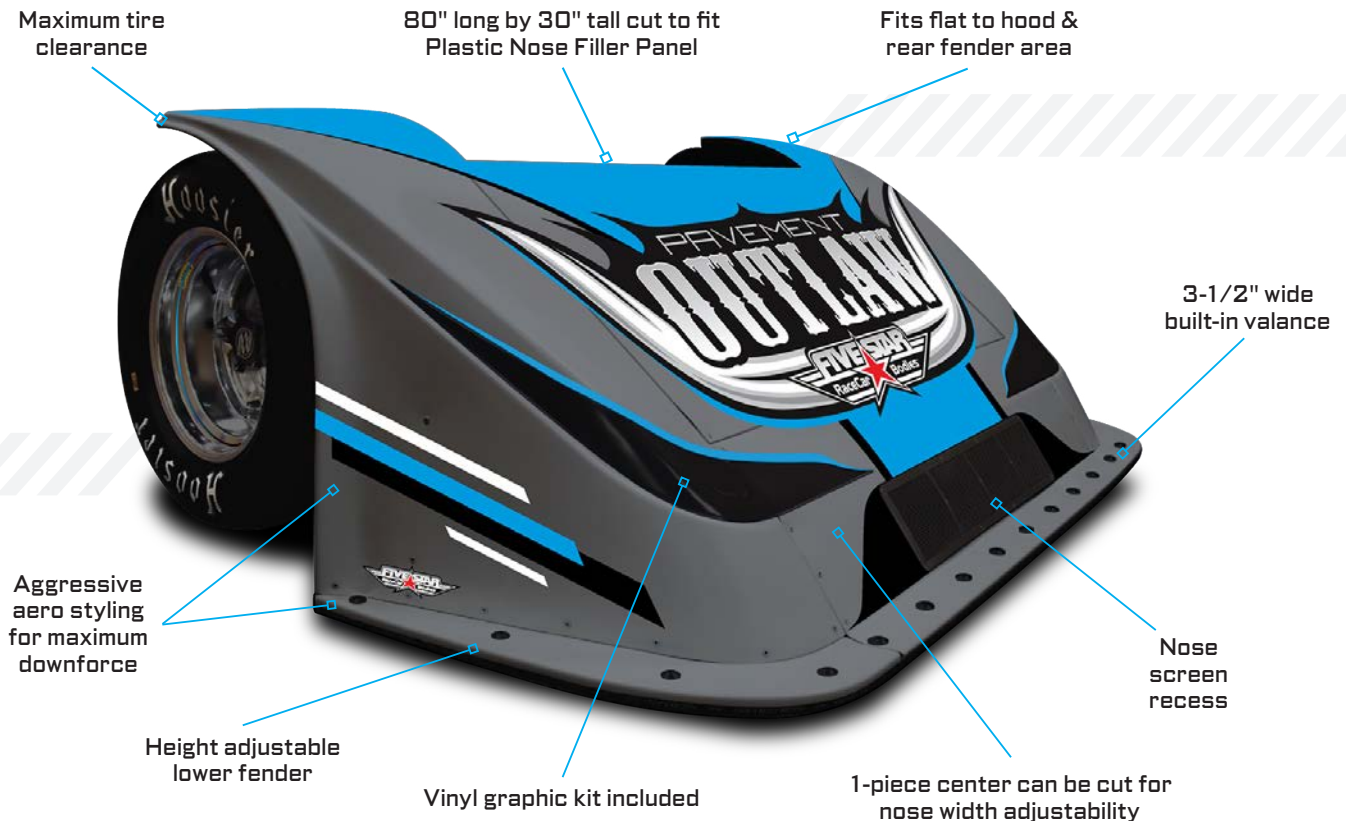

OUTLAW LATE MODEL

FEATURED BODY ACCESSORIES

PLASTIC NOSE FILLER PANEL:

- » 80" long by 30" tall
- » Flat high-impact plastic sheet deflects debris and resists chipping, denting, and bending.
- » Outperforms traditional aluminum panels in every way, this panel does not dent
- » For more details & ordering info, see page 56



OUTLAW SPORTSMAN COMPOSITE ROOF:

- » Strong! Holds up to high speeds with minimal bracing
- » Two options: Standard Composite & Advanced Lightweight Composite made with flame retardant resin for added driver safety
- » For more details & ordering info, see page 56



LOWER NOSE SUPPORT:

- » Add another layer of support with this lightweight, durable polyethylene plastic valance support
- » This lightweight, durable plastic nose support is .352" thick and adjusts from 86" to 96" long & can be trimmed to fit
- » For more details & ordering info, see page 56



UNIVERSAL BODY MOUNTING KIT:

- » Universal fit that can be used anywhere on a race car
- » Plastic kit features Black Delrin washers that withstand repeated impact and stress
- » For more details & ordering info, see page 147

» GO TO PAGES 144-167 TO SEE ALL ACCESSORIES FOR THIS BODY STYLE

ENGINEERED THROUGH THE DRIVER'S EYES



NORTH AMERICAN SPORTSMAN

THE SUPERIOR DESIGN FOR SPORTSMAN RACING

This is the spec body for the NASCAR Mexico Series and the top choice among competitors seeking cutting-edge performance. This body is a hassle free solution for any racer, setting a new standard for durability & aerodynamics in the sportsman division.





- » Universally designed for most sportsman divisions across North America
- » All panels have consistent, repeatable fit for effortless installation & replacement
- » 2-piece greenhouse includes a built-in cowl & deck lid filler
- » Common body has 3 nose options for brand identity
- » Panels feature mounting flanges & locating tabs
- » Designed for metric style chassis
- » Minimal trimming required
- » Available in 2 color options



NORTH AMERICAN SPORTSMAN

BODY PANELS & OPTIONS

HOW TO ORDER YOUR BODY IN 3 QUICK & EASY STEPS

» 1. SELECT BODY PACKAGE » 2. SELECT PANEL COLOR » 3. SELECT NOSE MAKE

RE-SKIN BODY PACKAGE

		-W	-B
Bumper Cover, Rear, high-impact plastic	12001-45051-x		\$152
Door, aluminum, left	12001-21033-xL		\$112
Door, aluminum, right	12001-21033-xR		\$112
Fender, high-impact plastic, left	11002-23051-xL		\$150
Fender, high-impact plastic, right	13002-23051-xR		\$150
Nose, high-impact plastic (SPECIFY MAKE: CAMARO-20132; MUSTANG-20321; CAMRY-20712)	20xxx-41051-x		\$177
Quarter Panel, high-impact plastic, left	12001-27351-xL		\$135
Quarter Panel, high-impact plastic, right	12001-27351-xR		\$135
Rocker Panel, fits either side, high-impact plastic (2 REQUIRED)	000-5501P-x		\$33
Rocker Panel, fits either side, high-impact plastic (ENTERED TWICE TO SHOW PACKAGE PRICE)	000-5501P-x		\$33
RE-SKIN BODY PACKAGE PRICE		12001-10000-x	\$1,189

COMPLETE BODY PACKAGE (RE-SKIN COMPONENTS PLUS ITEMS BELOW)

		-W	-B
Cowl Air Insert, Ultraglass composite	661-5100A-B		\$72
Deck Lid Hold-Down Strip, aluminum	XM 000-310H-x		\$10
Deck Lid, aluminum	661-310A-x		\$76
Greenhouse, Front, composite	12001-51311-x		\$498
Greenhouse, Rear, composite	12001-51511-x		\$530
Hood, flat, composite	12001-33011-x		\$320
Spoiler, Complete, 4pc, 3/16" poly blades, unpainted brackets, 5" x 60", 70°	11002-47357		\$129
Window, Quarter, coated, black-out border, 0.093", left	12001-65153-L		\$65
Window, Quarter, coated, black-out border, 0.093", right	12001-65153-R		\$65
Window, Rear, uncoated, 0.093"	12001-61151		\$201
Windshield, mar-resistant coated, 1/8"	12001-63253		\$377
COMPLETE BODY PACKAGE PRICE		12001-10600-x	\$3,532

*ALL WINDOWS ARE PRECUT TO FIT, BEVELED & DRILLED, WITH BLACK-OUT BORDER UNLESS OTHERWISE SPECIFIED.

NASCAR MEXICO SERIES SPECIFIC BODY PANELS

		-W	-B
Greenhouse, Front, long, composite	12001-51111-x		\$498
Door, aluminum, long, left	12001-21133-xL		\$112
Door, aluminum, long, right	12001-21133-xR		\$112

TO ENHANCE YOUR BODY PACKAGE, CHOOSE FROM THE OPTIONS BELOW:

BODY PACKAGE OPTIONS & UPGRADES (ADD OR SUBTRACT TO PACKAGE PRICE ABOVE FOR TOTAL)

			-W	-B	+/- PKG PRICE
Hood, scooped, composite	20002-33311-X		\$320		\$0
Rocker Panels, aluminum	000-5501A-X		\$39		+\$6
Spoilers: 60" wide	5" (90°)	5" (70°)	6-1/2" (90°)	6-1/2" (70°)	
Complete, aluminum	11002-47359	11002-47357	11002-47369	11002-47367	\$129 \$0
Complete, aluminum, black	11002-47359-B	11002-47357-B	11002-47369-B	11002-47367-B	\$139 +\$10

NORTH AMERICAN SPORTSMAN

BODY MOUNTING KIT

» EVERYTHING YOU NEED FOR THAT CLEAN & PROFESSIONAL INSTALL!

COMPLETE BODY MOUNTING KIT SAVE \$\$ WHEN PURCHASING COMPLETE KIT VERSUS INDIVIDUAL COMPONENTS!

Adjustable Body Braces (X3 @ \$35EA)	807-3	\$105
Aluminum Nose Side Braces, pair	11002-75333	\$15
Door Vent Windows, pair	000-6202	\$39
Front Bumper Mounting Kit	10001-72721	\$132
Front Bumper, 1-3/4", .065" steel	20002-71182	\$48
Graphics, Nose ID Kit (SPECIFY MAKE BELOW)	20xx2-44141	\$39
Graphics, Bumper Cover ID Kit (SPECIFY MAKE BELOW)	11xx2-44542	\$38
Hood Pin Bracket, 3/4" steel (4 PINS REQUIRED)	20002-34331	\$35
Hood Pin Kit, 3/8" pins (X2 @ \$15EA) SPECIFY COLOR: -B -CB -R	10001-34033-x	\$32
Nose Screen, stainless, 3/16"	660-4111	\$50
Rear Bumper Mounting Kit	802-2S	\$49
Rear Bumper, 1-3/4", .065" steel	11002-71682	\$48
Rear Deck Mounting Kit	660-450-RDK	\$89
Rear Window Brace Kit (3PC)	12001-76133	\$84
Universal Body Mounting Kit, plastic	00001-72651	\$29
Wear Strips, plastic SPECIFY COLOR: -W -B -CB -OR -R -Y -FG -FO -FR -FY	20002-41551-x	\$38
Window Installation Kit	805	\$27
Windshield Brace Kit (3PC)	12001-76333	\$84
COMPLETE KIT PRICE WITH 10% DISCOUNT	12001-72520	\$882.90

BODY MOUNTING KIT OPTIONS & UPGRADES (ADD GREEN \$ TO PACKAGE PRICE ABOVE FOR TOTAL)

Nose Screen, 1/4" spacing	660-4112	\$50	\$0	Nose Screen, black aluminum frame, 3/16"	10001-46333B	\$55	+\$5
Nose Screen, black, 1/4" spacing	660-4112-B	\$55	+\$5	Nose Screen, black aluminum frame, 1/4"	10001-46433B	\$55	+\$5
Nose Screen, black, 3/16" spacing	660-4111-B	\$55	+\$5	Universal Body Mounting Kit, aluminum	000-400K	\$49	+\$20

VINYL NOSE & BUMPER COVER GRAPHIC ID KITS FOR A REALISTIC OEM LOOK!

PRINTED ON OUTDOOR DURABLE HIGH-TACK VINYL • GLOSS LAMINATED SURFACE PROVIDES EXCELLENT PROTECTION



CHEVROLET CAMARO

Nose ID Kit	20132-44141	\$39
Bumper Cover ID Kit	11132-44542	\$38



FORD MUSTANG

Nose ID Kit	20321-44141	\$39
Bumper Cover ID Kit	11322-44541	\$38



TOYOTA CAMRY

Nose ID Kit	20712-44141	\$39
Bumper Cover ID Kit	11712-44541	\$38

» GO TO PAGES 144-167 TO SEE ALL COMPONENTS & ACCESSORIES FOR THIS BODY

PRICING SUBJECT TO CHANGE WITHOUT NOTICE

NORTH AMERICAN SPORTSMAN

FEATURED BODY ACCESSORIES



HOOD PIN KITS:

- » 2 pack kits includes the following:
 - 2 newly improved lightweight anodized and gun-drilled aluminum pins (half the weight of standard), 2 aluminum scuff plates, 2 flip-over steel clips, 4 jam nuts
- » For more details & ordering info, see page 149



UNIVERSAL BODY MOUNTING KIT:

- » Universal fit that can be used anywhere on a race car
- » Plastic kit features Black Delrin washers that withstand repeated impact and stress
- » For more details & ordering info, see page 147



HIGH-IMPACT PLASTIC WEAR STRIPS:

- » Height adjustable to seal the nose to the track to optimize aero and protection from wear
- » CNC-machined from Five Star's exclusive durable plastic
- » For more details & ordering info, see page 147



PREMIUM AVEX STYLE RIVETS:

- » Five Star Premium Rivets are known as the best quality on the market
- » Grip range up to 3/16" for 1/8" rivets & up to 1/2" for 3/16" rivets
- » Super-tight grip & won't spin out while drilling!
- » For more details & ordering info, see page 146

» GO TO PAGES 144-167 TO SEE ALL ACCESSORIES FOR THIS BODY STYLE

NORTH AMERICAN SPORTSMAN

BODY DIMENSIONS

FIVE STAR BODIES ARE DESIGNED TO MAINTAIN A PRECISE FIT WITH OPTIMIZED AERODYNAMICS!

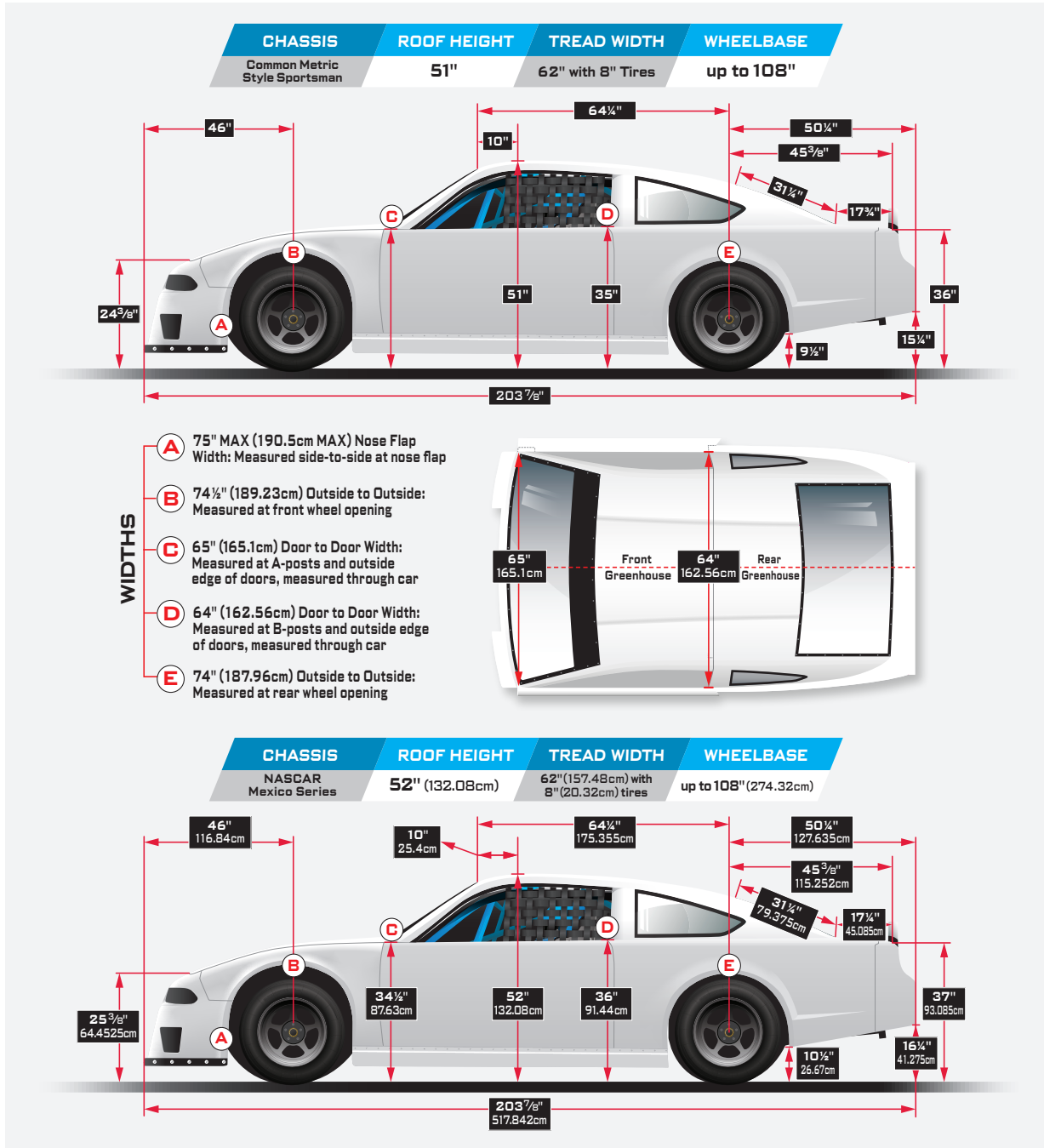

» FOR INDIVIDUAL BODY PANEL DIMENSIONS, VISIT FIVESTARBODIES.COM

PRICING SUBJECT TO CHANGE WITHOUT NOTICE

NORTH AMERICAN SPORTSMAN

BODY MOUNTING FIXTURES & TEMPLATES

MOUNT YOUR BODY FAST & EASY TO MAXIMIZE PERFORMANCE & TO PASS TECH INSPECTION!

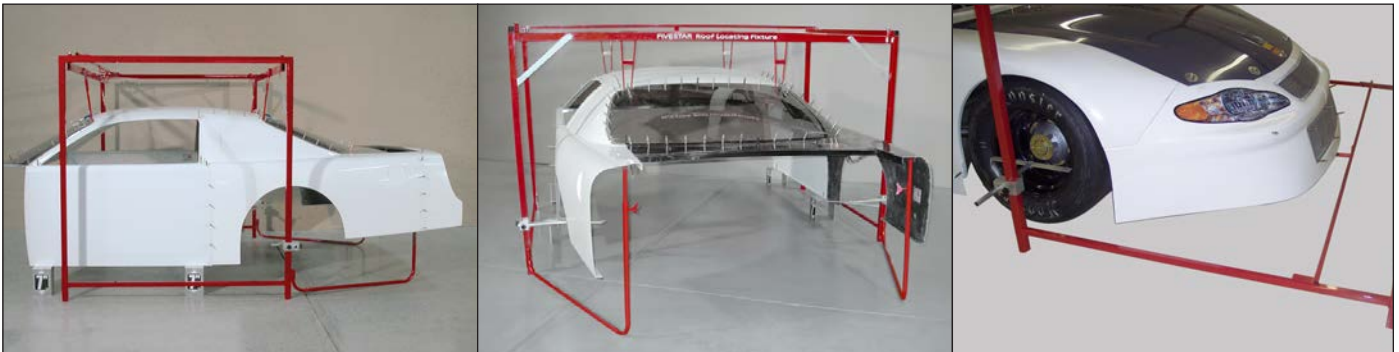

ROOF LOCATING FIXTURE

- » THE FAST & EASY WAY TO MOUNT YOUR COMPLETE BODY WITHOUT THE CHASSIS UNDERNEATH
- » This time-saving device has adjustable quarter panel arms and makes locating the roof on your chassis a simple process
- » Allows exact fit for wheel opening locations, body dimensions, and inspection templates to fit series specs
- » Pre-fits from the cowl to the bumper cover, then can be lifted easily on top of the chassis for final fit
- » Comes in a black powder-coat finish and includes roof brackets, door height blocks and assembly instructions

Roof Locating Fixture (includes Roof Brackets & Door Height Blocks)	809P	\$898
Replacement Roof Brackets	12001-72231	\$71
Replacement Door Height Blocks, 7" tall	809-HB	\$38

NORTH AMERICAN SPORTSMAN TEMPLATES ENSURE A CORRECT FIT FOR OPTIMUM AERODYNAMICS

- » Complete template set ensures body is installed correctly
- » Complete sets include: Body Centerline, Fenders, Nose Centerline, Nose Side-to-Side, Front & Rear Roof Side-to-Side
- » Nose and fender templates are specific to model
- » Common templates can check all models
- » Master sets available with templates for all models

Template, Complete Set, wood, Chevrolet	12131-82091	\$337
Template, Complete Set, wood, Ford	12321-82091	\$337
Template, Complete Set, wood, Toyota	12712-82091	\$337

BODY PANEL MOUNTING TOOLS



FIVE STAR PREMIUM AVEX STYLE RIVETS

- » The best quality on the market!
- » Five Star Rivets have a super-tight grip, won't spin out while drilling & pull much tighter than other, cheaper rivets.
- » For more details & ordering info, see page 146



CLECO KIT & PLIERS:

- » Cleco pliers & Cleco fasteners ensure perfect alignment every time
- » Clecos can be easily inserted with the cleco pliers to temporarily hold panels during the body mounting process
- » For more details & ordering info, see page 161

» FOR MORE BODY MOUNTING TOOLS, GO TO PAGES 144-167

ADDITIONAL BODY STYLES

AVAILABLE ON OUR WEBSITE

» VISIT FIVESTARBODIES.COM FOR ORDERING INFO!



OLDER FIBERGLASS



SPORTSMAN



STRAIGHT UP



METAL



52



SPORTSMAN



MINISTOCK



MUSTANG



DIRT GRAND



NATIONAL



TROPHY KART



TRUCK



OFF ROAD



TRUCK

» KEEP UP TO SPEED, FOLLOW US ON SOCIAL MEDIA!





NEW CROWN VIC
INTERCEPTOR
NOSE & BUMPER COVER



- » Molded Plastic Panels Provide Unmatched Flexibility & Durability
- » Replace Old, Hard-to-Find Junkyard Panels
- » Great for Both Dirt & Pavement Racing
- » Excellent Fit, Easy to Install

CROWN VIC INTERCEPTOR NOSE



Nose, high-impact plastic 50361-41051-X \$181

CROWN VIC INTERCEPTOR BUMPER COVER



Bumper Cover, high-impact plastic 50361-45051-X \$160

REPLACEMENT POLYCARBONATE WINDSHIELD

Windshield, mar-resistant coated, 1/8" 50361-63233 \$377

NEW BANDOLERO & LEGEND CAR WINDSHIELDS

- » Pre-cut & Drilled for Easy Install
- » Screen-Printed Blackout Borders
- » Scratch Resistant Coating

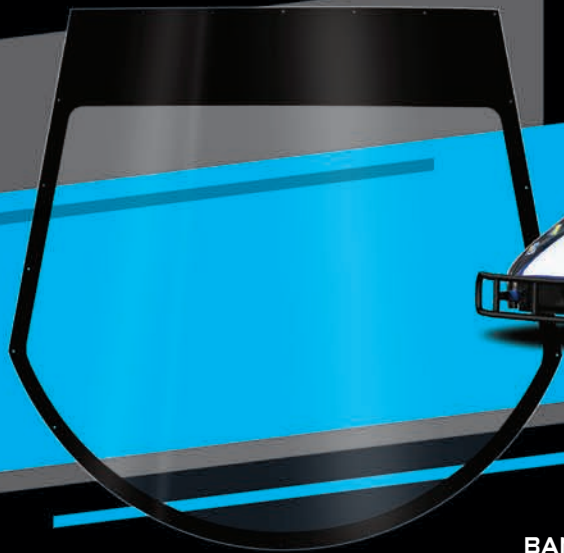

BANDOLERO WINDSHIELD

Windshield, mar-resistant coated, 1/8" 23001-63253 \$300



'34 FORD COUPE LEGEND CAR WINDSHIELD

Windshield, mar-resistant coated, 1/8" 19371-63143 \$75

ENGINEERED THROUGH THE DRIVER'S EYES



DIRT LATE MODEL

THE #1 CHOICE FOR DIRT RACERS

All panels are designed with great style, provide maximum downforce,
& are proven to be the most durable, cost-effective
products on the market.





- » Molded plastic panels provide unmatched flexibility and durability
- » Advanced lightweight composite panels are very close to a carbon fiber blend in strength & weight
- » Premium plastic materials available exclusively in MD3 products
- » Achieve maximum vinyl adhesion by using MD3 Adhesion Promoter
- » See color options for all body panels & components in ordering section

W WHITE	G GRAY	B BLACK	CB BLUE	R RED	O ORANGE	Y YELLOW	FG FLUOR. GRN	FO FLUOR. ORG	FR FLUOR. RED	FY FLUOR. YEL
-------------------	------------------	-------------------	-------------------	-----------------	--------------------	--------------------	-------------------------	-------------------------	-------------------------	-------------------------

CONNECT WITH TEAM FIVE STAR | FIVESTARBODIES.COM    

DIRT LATE MODEL

EVOLUTION 2 NOSE COMBO KIT

EVOLUTION 2 NOSE COMBO KIT

		-W	-B	-CB	-G	-OR	-R	-Y	-FG	-FO	-FR	-FY	
Nose, 2-piece, high-impact plastic	32004-41051-x											N/A	
Nose Lower Aero Valance, high-impact plastic	32004-41751-x											\$87	
Fender, upper, left, high-impact plastic	32004-23251-xL											N/A	
Fender, upper, right, high-impact plastic	32004-23251-xR											N/A	
Fender, lower, left, high-impact plastic	32004-23351-xL											\$56	
Fender, lower, right, high-impact plastic	32004-23351-xR											\$56	
NOSE COMBO KIT PRICE		32004-43554-x										\$507	\$560

TO ADD A REALISTIC OEM LOOK TO YOUR NOSE, SEE VINYL NOSE GRAPHIC ID KITS | PAGE 79



2-PIECE UPPER & LOWER FENDERS ALLOWS FOR EXACT GROUND HEIGHT ADJUSTMENT



Right Fender has more clearance for tire travel to allow for lower mounting height.

Left Fender is raised for maximum downforce



Lower Fenders are separate for improved fit, have a tapered valance built-in, and are thicker for improved durability. Also adjustable to meet desired ground clearance.

Lower Aero Valance (below the nose) is tapered and is thicker for improved durability.

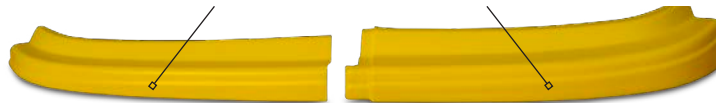

Separate lower right front fender for quick & easy replacement.

COMPLETE COMMON BODY PACKAGE NOSE COMBO KIT PLUS ITEMS BELOW

		-W	-B	-CB	-G	-OR	-R	-Y	-FG	-FO	-FR	-FY	
Door, high-impact plastic, right (N/A IN GRAY)	32001-21051-xR											N/A	
Hood, composite (N/A IN GRAY)	32003-33512-x											N/A	
Nose Filler Panel, high-impact plastic	32000-35851-x											N/A	
Quarter Panel, high-impact plastic, right (N/A IN GRAY)	32001-27351-xR											N/A	
Roof, composite (N/A IN GRAY)	006-5101L-x											N/A	
Roof Cap, plastic (N/A IN GRAY) (CARBON FIBER -CF AVAILABLE FOR \$38)	006-500-x											\$35	
Rocker Panel, fits either side, high-impact plastic (3 REQUIRED)	007-5500-x											\$46	
Rocker Panel, fits either side, high-impact plastic (ENTERED AGAIN TO SHOW PACKAGE PRICE)	007-5500-x											\$46	
Rocker Panel, fits either side, high-impact plastic (ENTERED AGAIN TO SHOW PACKAGE PRICE)	007-5500-x											\$46	
COMPLETE BODY PACKAGE PRICE		32004-10352-x										\$2,046	\$2,117

DIRT LATE MODEL

EVOLUTION NOSE COMBO KIT

EVOLUTION NOSE COMBO KIT

		-W	-B	-CB	-G	-OR	-R	-Y	-FG	-FO	-FR	-FY
Nose, 2-piece, high-impact plastic	32003-41051-X											N/A
Fender, left, high-impact plastic	32003-23051-XL											N/A
Fender, right, high-impact plastic	32003-24051-XR (FLAT)	32003-23051-XR (RAISED)										N/A
NOSE COMBO KIT PRICE		32003-43554-x										\$371

TO ADD A REALISTIC OEM LOOK TO YOUR NOSE, SEE VINYL NOSE GRAPHIC ID KITS | PAGE 79



COMPLETE COMMON BODY PACKAGE NOSE COMBO KIT PLUS ITEMS BELOW

		-W	-B	-CB	-G	-OR	-R	-Y	-FG	-FO	-FR	-FY
Door, high-impact plastic, right (N/A IN GRAY OR YELLOW)	32001-21051-xR											N/A
Hood, composite (N/A IN GRAY OR YELLOW)	32003-33512-x											N/A
Nose Filler Panel, high-impact plastic (N/A IN YELLOW)	32000-35851-x											N/A
Nose Aero Valance, lower, high-impact plastic (N/A IN YELLOW)	32003-41751-x											\$98
Quarter Panel, high-impact plastic, right (N/A IN GRAY OR YELLOW)	32001-27351-xR											N/A
Roof, composite (N/A IN GRAY)	006-5101L-x											N/A
Roof Cap, plastic (N/A IN GRAY) (CARBON FIBER -CF AVAILABLE FOR \$38)	006-500-x											\$35
Rocker Panel, fits either side, high-impact plastic (3 REQUIRED)	007-5500-x											\$46
Rocker Panel, fits either side, high-impact plastic (ENTERED AGAIN TO SHOW PACKAGE PRICE)	007-5500-x											\$46
Rocker Panel, fits either side, high-impact plastic (ENTERED AGAIN TO SHOW PACKAGE PRICE)	007-5500-x											\$46
COMPLETE COMMON BODY PACKAGE PRICE		32003-10352-x										\$2,026

PRICING SUBJECT TO CHANGE WITHOUT NOTICE

DIRT LATE MODEL

BODY PANELS & COMPONENTS

FIVE STAR BODY PANELS ARE DESIGNED TO MAINTAIN PRECISE FIT WITH OPTIMIZED AERODYNAMICS!



3" CURVED SCOOP

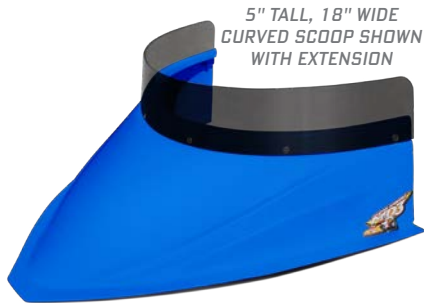

5" TALL, 18" WIDE CURVED SCOOP SHOWN WITH EXTENSION



OVERSIZED 80" X 30" PANEL IS TRIM-TO-FIT FOR YOUR CUSTOM APPLICATION

HOOD SCOOPS

- » Lightweight, molded high-impact plastic scoops are shaped for peak aero performance
- » Three options to choose from: 3" tall x 16" wide, 5" tall x 16" wide and the all new 5" tall x 18" wide
- » Raise the height of your Hood Scoop using a polycarbonate Hood Scoop Extension to protect your air filter!
- » Available in 4 colors including a carbon fiber look; appearance of carbon fiber, at a fraction of the cost.

-W -CB -R -CF

Hood Scoop, 3" tall x 16" wide, curved	040-4114-X	\$52	\$59
Hood Scoop, 5" tall x 16" wide, curved	040-4116-X	\$52	\$59
Hood Scoop, 5" tall x 18" wide, curved	040-4118-X	\$52	\$61
Hood Scoop Extension, Tinted, 3"x16"	040-4117-TNT	\$38	N/A
Hood Scoop Extension, Tinted, 3"x18"	040-4119-TNT	\$41	N/A

PLASTIC NOSE FILLER PANEL

- » Mounts between the nose, hood and fenders
- » Flat high-impact plastic sheet deflects debris and resists chipping, denting, bending
- » Outperforms traditional aluminum panels in every way!
- » Flame retardant material with high heat distortion temperature
- » Same weight per square foot as .040" aluminum!
- » Available in 5 colors **-W -B -CB -G -R**

Nose Filler Panel	32000-35851-X	\$128
-------------------	---------------	-------

THE TOUGHEST SPOILER ON THE MARKET!

ABC LMSG TRUCK PAVMOD OUTLAW LATE MODEL SPORTSMAN OLDER BODIES MD3 LATE MODEL MD3 MODIFIED NORTHEAST MOD STOCK CAR STREET STOCK TAZ PRO STOCK/MOD FUNNY CAR JR RASTER WINDOWS ACCESSORIES

NEW!

COMPLETE SPOILER KIT

- » Built out of 0.080 aluminum & high-impact plastic
- » Brackets built into left side blade for quick & easy adjustment
- » Kit includes: 8" tall x 56" wide left side blade with a 1" lip, 1 56-1/4" aluminum hinge, 3 spoiler side supports, 1 center support, and 1 molded high-impact plastic breakaway spoiler kit
- » Available in 5 colors

-W -B -CB -G -R

Complete Spoiler Kit	32000-72821-x	\$212
----------------------	---------------	-------

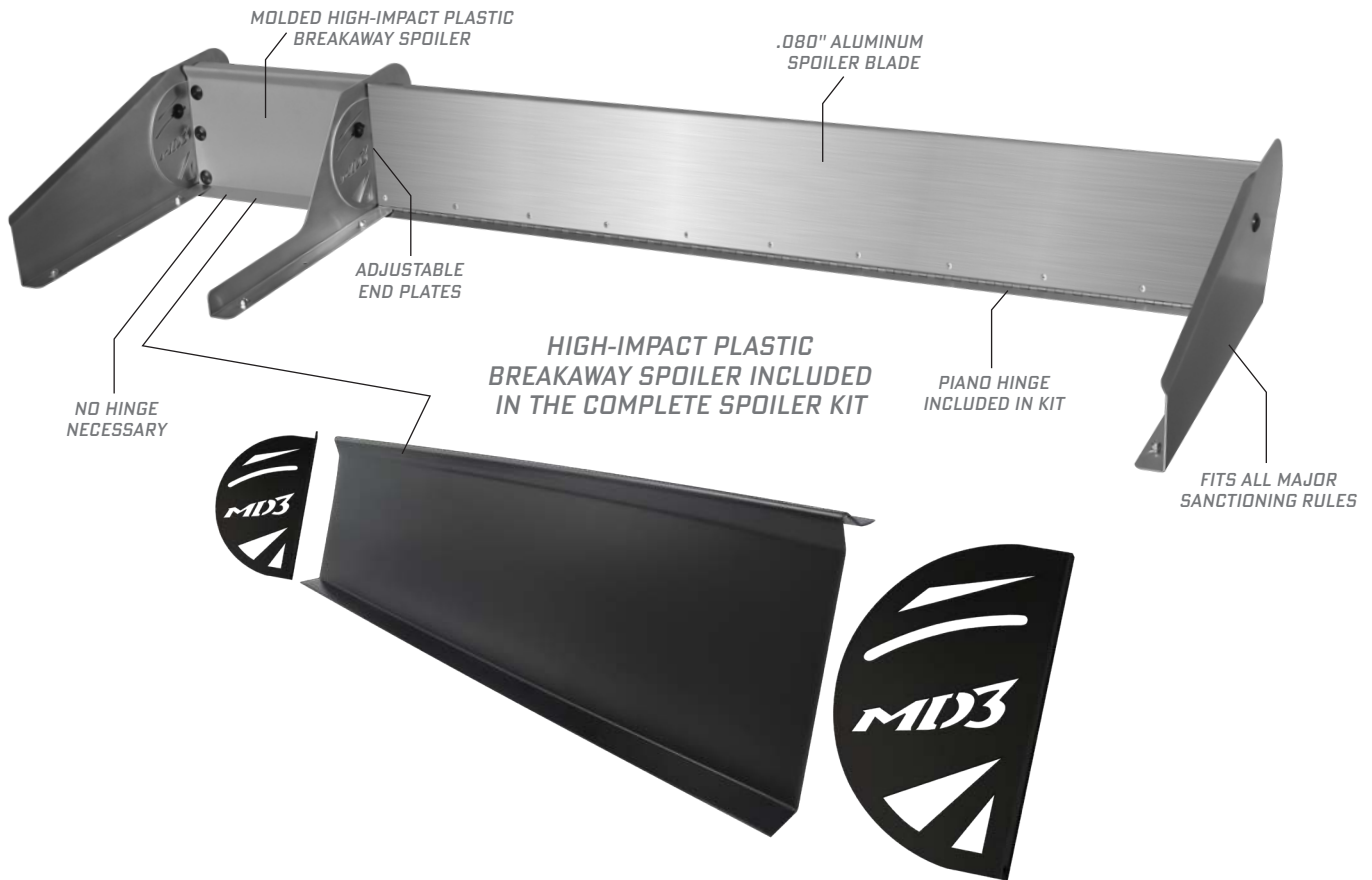

MOLDED HIGH-IMPACT PLASTIC BREAKAWAY SPOILER KIT

- » **PLASTIC SPOILER BLADE:** Made of lightweight, molded high-impact plastic
- » 32" wide by 8 1/4" tall
- » **ALUMINUM ADJUSTABLE END PLATES:**
- » Made of premium high-strength aluminum with powder-coated finish
- » 4-1/2" wide by 7" tall
- » CNC machined slots make for easy spoiler angle adjustment
- » Kit includes: 1-Plastic Spoiler and 2-Aluminum Adjustable End Plates and is available in 5 colors

-W -B -CB -G -R

Molded High-Impact Plastic Breakaway Spoiler Kit	32000-72820-X	\$69
Plastic Right Side Spoiler Blade	32000-47751-X	\$29
Adjustable End Plates, pair	32000-47851-X	\$40
Adjustable End Plate, left	32001-47851L-X	\$20
Adjustable End Plate, right	32001-47851R-X	\$20



LEFT & RIGHT SIDE
REPLACEMENT PLATES

PRICING SUBJECT TO CHANGE WITHOUT NOTICE

DIRT LATE MODEL

BODY PANELS & COMPONENTS

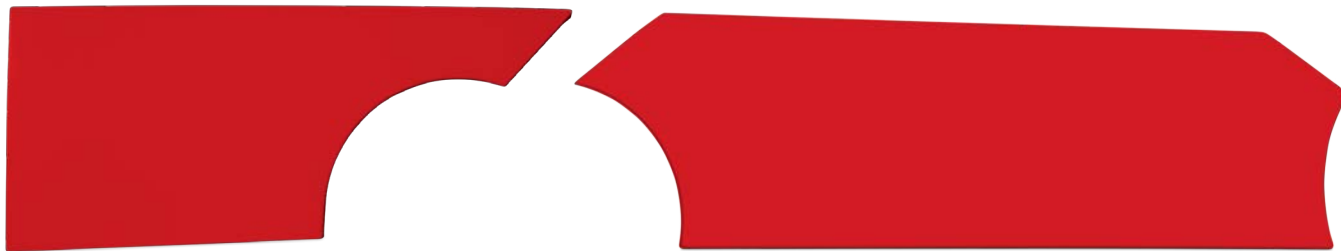

PLASTIC QUARTER PANEL

Quarter Panel, right	32001-27351-xR	\$119
----------------------	----------------	-------

PLASTIC RIGHT SIDE DOOR

Door, right	32001-21051-xR	\$152
-------------	----------------	-------

- » Molded high-impact plastic out performs aluminum in every way
- » Resists chipping, denting, & bending
- » Common design to fit most late model chassis
- » Meets all flame resistance test requirements
- » Molded flanges for added rigidity & easy installation
- » Approved for competition by all major national sanctioning series
- » Available in 5 colors **-W -B -G -CB -R**

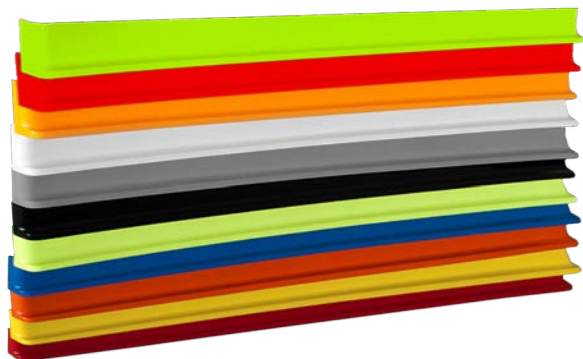

PLASTIC ROCKER PANEL

- » These 77-3/4" x 7-1/4" lightweight, high-impact plastic rockers are aerodynamically designed for the best side force
- » They are easy to mount and add structural integrity to side body panels
- » Available in 11 colors

-W -B -G -CB -R -Y -OR -FG -FO -FR -FY

Rocker Panel	007-5500-x	\$40ea	\$46ea
--------------	------------	--------	--------

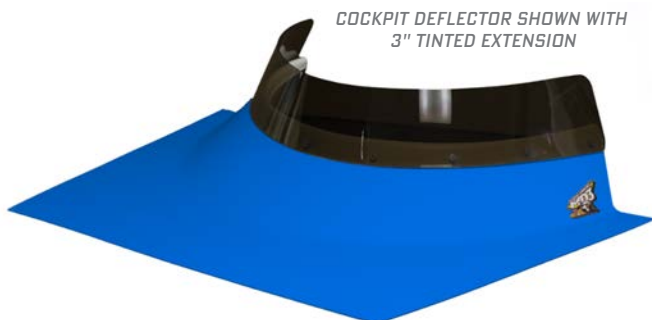

COCKPIT DEFLECTOR SHOWN WITH
3" TINTED EXTENSION

COCKPIT DEFLECTORS

- » High-impact molded plastic deflectors are ultra durable, withstand flying debris and divert air around the driver
- » Available in 6 colors **-W -B -G -CB -R -Y**
- » Raise the height of your cockpit deflector using a polycarbonate Cockpit Extension to allow for more visibility
- » Cockpit Extension available in 3" and 4" height, clear & tinted

Cockpit Deflector, plastic	040-4106-X	\$74
Cockpit Extension, Clear, 3"	040-4107-CLR	\$49
Cockpit Extension, Tinted, 3"	040-4107-TNT	\$49
Cockpit Extension, Clear, 4"	040-4108-CLR	\$58
Cockpit Extension, Tinted, 4"	040-4108-TNT	\$58

SHAPED FOR PEAK AERO PERFORMANCE WITH TREMENDOUS SHEAR (TEAR) RESISTANCE



LIGHTWEIGHT COMPOSITE HOOD

- » Holds shape at all speeds with minimal or no bracing!
- » Made from advanced lightweight composites
- » Weighs less than 8lbs!
- » Slightly oversized and can be trimmed to fit
- » Available in 5 colors

-W -B -CB -R -Y

Hood	32003-33512-x	\$486
------	---------------	-------

YELLOW COMPOSITE BODY PANELS ARE SPECIAL ORDER PARTS, CONTACT FIVE STAR FOR AVAILABILITY AND LEAD TIME*

ENHANCED DESIGN FOR IMPROVED AERODYNAMICS



LIGHTWEIGHT COMPOSITE ROOF

- » Strong! Holds up to high speeds with minimal bracing
- » Advanced lightweight composite roof now made with Flame Retardant resin for added driver safety
- » 48" wide x 44" long, minimal bracing required
- » Weighs less than 7lbs!
- » Meets all sanctioning rules
- » Available in 4 colors

-W -B -CB -R

Roof	006-5101L-X	\$499
------	-------------	-------

YELLOW COMPOSITE BODY PANELS ARE SPECIAL ORDER PARTS, CONTACT FIVE STAR FOR AVAILABILITY AND LEAD TIME*

PLASTIC ROOF CAPS

- » Made of high-impact molded plastic
- » 45-1/4" long and weighs only 8oz!
- » Available in 11 colors including a carbon fiber look (appearance of carbon fiber)

-W -B -CB -R -Y -OR -FG -FO -FR -FY -CF

Roof Cap	006-500-x	\$35	\$38
----------	-----------	------	------



CARBON FIBER LOOK CLOSE-UP (-CF)

DIRT LATE MODEL

BODY PANELS & COMPONENTS

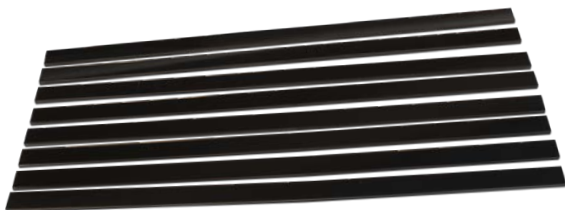

1-1/4" WIDE X 36" LONG X (FLAT) 0.30" THICK



STANDARD PLASTIC BODY BRACES

- » Constructed of the same specially-blended, high-impact plastic as our MD3 noses
- » Each lightweight brace weighs only 7 oz
- » Perfect for taking abuse on the dirt
- » 1-1/4" wide x 36" long x (flat) 0.30" thick
- » Trims easily to fit your needs

-B

Single Body Brace	040-8000	\$11 ea
Pkg of (8) Body Braces	040-8000-8	\$58



PLASTIC LOWER NOSE SUPPORT

- » This lightweight, durable plastic 37" long nose support is made out of .350" thick polyethylene
- » Fits either side of your nose
- » Two are required for a complete install
- » Available in black only

Nose Support	32003-410-1	\$42 EA
--------------	-------------	---------



OIL COOLER SCOOP

- » High-impact molded plastic scoop has a sleek aerodynamic design that directs air for cooling
- » Can be mounted forward or backward!
- » Available in white and a carbon fiber look; appearance of carbon fiber, at a fraction of the cost

-W-CF

Oil Cooler Scoop	040-4105-X	\$29
------------------	------------	------

SCAN HERE TO



SHOP ONLINE

» FOR OLDER DIRT LATE MODEL BODY PANELS, VISIT OUR WEBSITE!



ALL NEW MD3 AIR FILTER SHIELD

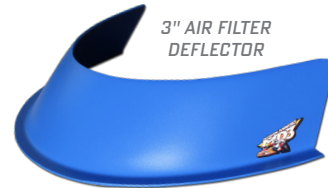

AIR FILTER SHIELD

- » The perfect solution for unexpected weather at the track
- » Durable & lightweight molded plastic
- » Quick & easy install & removal

Air Filter Shield	30001-35451-B	\$39
-------------------	---------------	------

NEW!

AIR FILTER DEFLECTORS

- » Lightweight, high-impact molded plastic deflectors have a sleek aerodynamic design that provides maximum air filter protection
- » Three options to choose from: 3", 5", and 6" height
- » Available in 4 colors including a carbon fiber look; appearance of carbon fiber, at a fraction of the cost.

		-W	-CB	-R	-CF
Air Deflector, 3" tall x 16" wide	040-4100-X	\$40			\$47
Air Deflector, 5" tall x 15" wide	040-4101-X	\$40			\$47
Air Deflector, 6" tall x 18" wide	040-4102-X	\$48			\$55

PRICING SUBJECT TO CHANGE WITHOUT NOTICE



PREMIUM UNIVERSAL PLASTIC FLAT SHEETS

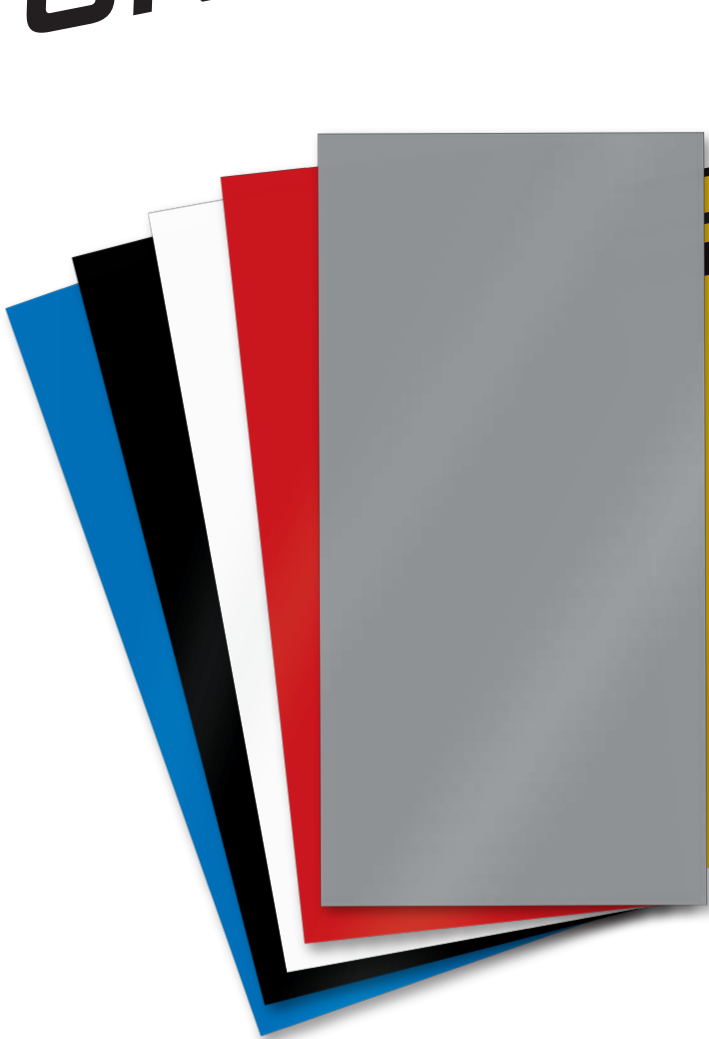

- » Replace traditional aluminum with this extremely durable plastic
- » Resists chipping, denting, bending to last much longer than aluminum panels
- » Flame retardant with high heat distortion temperature
- » Trims easily with shears
- » Can be bent in a brake
- ».140" thick

**4'x8' & 3'x9.5' FLAT SHEETS
READY TO CUT & FIT!**

UNIVERSAL PLASTIC FLAT SHEETS

» Available in 5 colors **-W -B -G -CB -R**

4'x8' Sheet	30001-93051-X	\$142
3'x9.5' Sheet	30001-93151-X	\$125

» REPLACE TRADITIONAL ALUMINUM WITH OUR HIGH-IMPACT PLASTIC!

DIRT LATE MODEL

VINYL NOSE GRAPHIC ID KITS

- » **HIGH-TACK ADHESION:** Our outdoor durable vinyl with aggressive adhesive ensures that your nose graphics stay securely in place
- » **EXTREME DURABILITY:** Gloss laminated surface provides excellent protection to maintain their brilliant appearance even under the harshest conditions
- » **EASY APPLICATION:** Installing our graphics is a breeze! With our easy-to-follow application instructions, premium-grade vinyl & the all new MD3 Adhesion Promoter, you can achieve a smooth, professional looking install!



CHEVROLET CAMARO

32133-44142 Evolution 2 & Evolution Nose ID Kit \$39



CHEVROLET SS

32123-44141 Evolution 2 & Evolution Nose ID Kit \$39



FORD MUSTANG

32323-44141 Evolution 2 & Evolution Nose ID Kit \$39



TOYOTA CAMRY

740-410-ID Evolution 2, Evolution and Original Nose ID Kit \$39

MOST ID KITS HAVE A UNIVERSAL FIT FOR ALL MD3 NOSE COMBOS

MD3 ADHESION PROMOTER

- » Specifically engineered adhesion promoter assures proper paint bonding to our special plastic
- » Other automotive grade primers on the market may not work at all or cause severe paint flaking
- » Improves adhesion of vinyl by enhancing the bond between adhesive on the vinyl and the substrate, for a more durable, long-lasting application
- » Comes in an aerosol spray can for quick and easy application
- » A single can coats approximately 5 individual parts

MD3 Adhesion Promoter 842 \$16



» FOR OLDER DIRT LATE MODEL BODY PANELS, VISIT OUR WEBSITE!

ENGINEERED THROUGH THE DRIVER'S EYES



DIRT MODIFIED

PROVEN BEST BODY PANELS IN ALL DIRT RACING

The MD3 Dirt Modified High-Impact Plastic body panels, make it the ultimate body choice in all dirt modified racing due to its durability and performance on the track.





- » Molded plastic panels provide unmatched flexibility and durability
- » Premium plastic materials available exclusively in MD3 products
- » Achieve maximum vinyl adhesion by using MD3 Adhesion Promoter
- » See color options for all body panels and components in ordering section



CONNECT WITH TEAM FIVE STAR | FIVESTARBODIES.COM    

DIRT MODIFIED

BODY PANELS & COMPONENTS

FIVE STAR BODY PANELS ARE DESIGNED TO MAINTAIN PRECISE FIT WITH OPTIMIZED AERODYNAMICS!

PLASTIC NOSE KIT

- » This high-impact plastic nose is oversized
- » Trim to fit your modified
- » Outperforms traditional aluminum panels in every way
- » Legal for all sanctioning bodies
- » Available in 5 colors

-W -B -G -CB -R

Nose, Complete Kit	34001-41051-x	\$169
Nose Side, left	34001-41451-xL	\$32.50
Nose Side, right	34001-41451-xR	\$32.50
Nose, Center, Upper	34001-41251-x	\$52
Nose, Center, Lower	34001-41151-x	\$52
Nose Filler Panel, 1-piece (Optional)	34000-35851-x	\$124

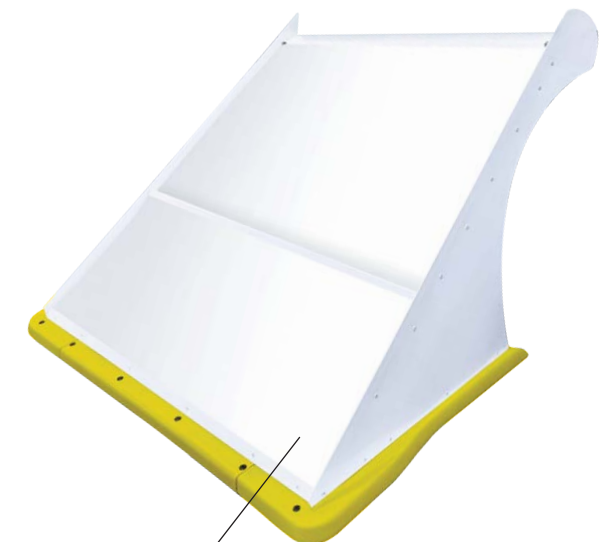

HIGH-IMPACT PLASTIC LOWER AERO VALANCE

- » This adjustable 3-piece assembly has overlapping flanges that fit together perfectly, making it easy to mount for desired ground clearance
- » Universal fit for modified aluminum noses up to 45" wide
- » Adjustable front overhang up to 42"
- » Available in 11 colors

-W -B -G -CB -R -Y -OR -FG -FO -FR -FY

Lower Aero Valance	3022-417-x	\$95	\$120
--------------------	------------	------	-------

LOWER AERO VALANCE SUPPORT

- » Add another layer of support with this lightweight, durable polyethylene plastic valance support
- » It is made of .350" thick polyethylene and will fit either side of your lower aero valance
- » Two are required for a complete install; available in black only

Lower Aero Valance Support	3022-410-1	\$26 ea
----------------------------	------------	---------

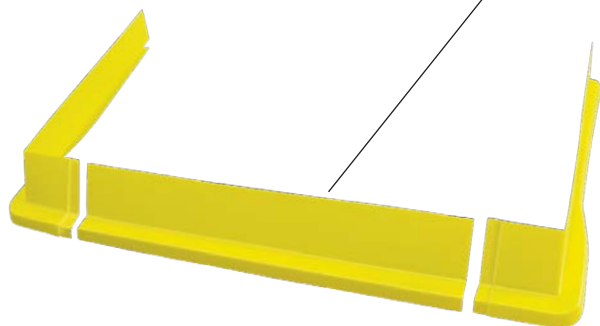

OVERLAPPING FLANGES
MAKE THIS EASY TO INSTALL.



THE HOTTEST PANELS IN MODIFIED RACING!

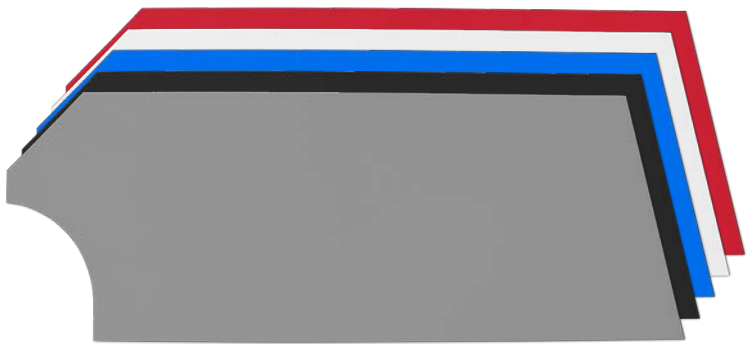
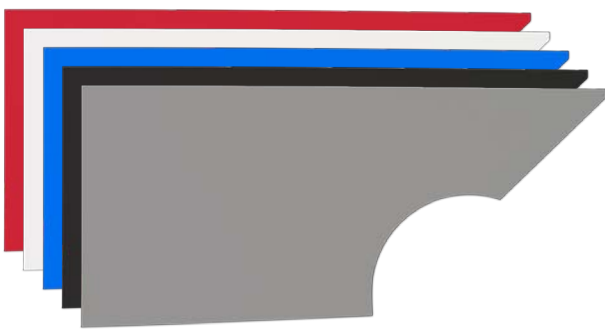

PLASTIC DOORS

Door, left	34001-21051-xL	\$98
Door, right	34001-21051-xR	\$91

PLASTIC QUARTER PANELS

Quarter Panel, left	34001-27351-xL	\$72
Quarter Panel, right	34001-27351-xR	\$63

- » Exclusive MD3 molded plastic panels provide unmatched durability
- » Repeatable flange fit panels for easy installation and replacement
- » Molded wheel well & nerf bar mounting holes
- » Meets all flame resistance test requirements
- » Approved for competition by all major national sanctioning series
- » Available in 5 colors **-W -B -G -CB -R**

PLASTIC ROCKER PANEL

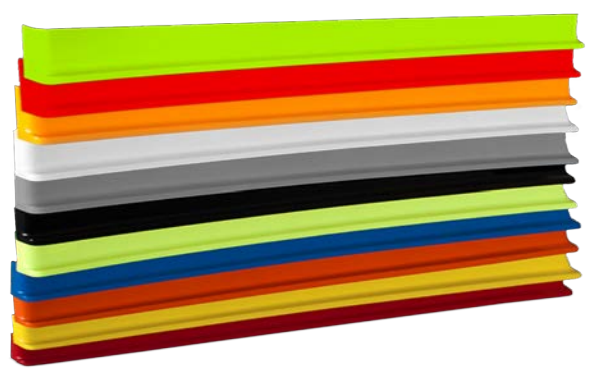

- » These 77-3/4" x 7-1/4" lightweight, high-impact plastic rockers are aerodynamically designed for the best side force
- » They are easy to mount & add structural integrity to side body panels
- » 3 rockers needed for a complete install
- » Available in 11 colors **-W -B -G -CB -R -Y -OR -FG -FO -FR -FY**

Rocker Panel	007-5500-x	\$40ea	\$46ea
--------------	------------	--------	--------

ACHIEVE MAXIMUM VINYL ADHESION BY USING MD3 ADHESION PROMOTER. DETAILS AND ORDERING INFORMATION ON PAGE 167!



DIRT MODIFIED

BODY PANELS & COMPONENTS

FULLY INSTALLED
WHEEL FLARES & ROCKERS



PLASTIC WHEEL FLARES

- » Prevent tires from being cut with these lightweight, high-impact plastic wheel flares
- » Inset wheel flares fit around the full rear wheel opening
- » Available in 11 colors

-W -B -G -CB -R -Y -OR -FG -FO -FR -FY

Wheel Flares (3pcs left)	007-261-xL	\$54	\$67
Wheel Flares (3pcs right)	007-261-xR	\$54	\$67

WHEEL FLARE & ROCKER KIT

- » These interconnecting pieces enhance downforce and side force while adding rigidity to the sides of the body!
- » 3 rockers complete installation: 1 rocker between each front and rear wheel flare and a half piece behind each rear wheel flare

-W -B -G -CB -R -Y -OR -FG -FO -FR -FY

Wheel Flare & Rocker Kit	007-2615-x	\$228	\$272
--------------------------	------------	-------	-------

3" FLAT SCOOP



5" FLAT SCOOP

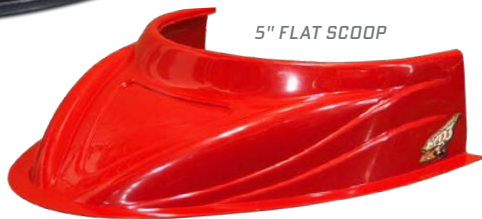

HOOD SCOOPS

- » Lightweight, molded high-impact plastic scoops are shaped for peak aero performance
- » Two options to choose from: 3" tall x 16" wide, 5" tall x 16" wide
- » Available in 4 colors including a carbon fiber look; appearance of carbon fiber, at a fraction of the cost.

-W -CB -R -CF

Hood Scoop, 3" tall x 16" wide, flat	040-4115-x	\$52	\$59
Hood Scoop, 5" tall x 16" wide, flat	040-4113-x	\$52	\$59

SCAN HERE TO



SHOP ONLINE

» FOR INDIVIDUAL BODY PANEL DIMENSIONS, VISIT FIVESTARBODIES.COM



ALL NEW MD3 AIR FILTER SHIELD



AIR FILTER SHIELD

- » The perfect solution for unexpected weather at the track
- » Durable & lightweight molded plastic
- » Quick & easy install & removal

Air Filter Shield	30001-35451-B	\$39
-------------------	---------------	------

NEW!



3" AIR FILTER DEFLECTOR



5" AIR FILTER DEFLECTOR



6" AIR FILTER DEFLECTOR

AIR FILTER DEFLECTORS

- » Lightweight, high-impact molded plastic deflectors have a sleek aerodynamic design that provides maximum air filter protection
- » Three options to choose from: 3", 5", and 6" height
- » Available in 4 colors including a carbon fiber look; appearance of carbon fiber, at a fraction of the cost.

		-W-CB-R	-CF
Air Deflector, 3" tall x 16" wide	040-4100-x	\$40	\$47
Air Deflector, 5" tall x 15" wide	040-4101-x	\$40	\$47
Air Deflector, 6" tall x 18" wide	040-4102-x	\$48	\$55

PRICING SUBJECT TO CHANGE WITHOUT NOTICE

DIRT MODIFIED

BODY PANELS & COMPONENTS

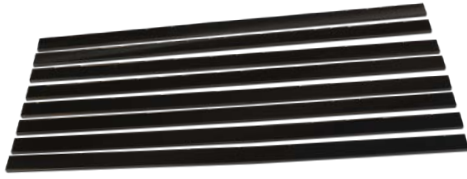

1-1/4" WIDE X 36" LONG X (FLAT)



STANDARD PLASTIC BODY BRACES

- » Constructed of the same specially-blended, high-impact plastic as our MD3 noses
- » Each lightweight brace weighs only 7 oz
- » Perfect for taking abuse on the dirt
- » 1-1/4" wide x 36" long x (flat) 0.30" thick
- » Trims easily to fit your needs

B

Single Body Brace	040-8000	\$11 ea
Pkg of (8) Body Braces	040-8000-8	\$58



OIL COOLER SCOOP

- » High-impact molded plastic scoop has a sleek aerodynamic design that directs air for cooling
- » Can be mounted forward or backward!
- » Available in white and a carbon fiber look; appearance of carbon fiber, at a fraction of the cost.

-W-CF

Oil Cooler Scoop	040-4105-x	\$29
------------------	------------	------

MD3 ADHESION PROMOTER

- » Specifically engineered adhesion promoter assures proper paint bonding to our special plastic
- » Other automotive grade primers on the market may not work at all or cause severe paint flaking
- » Improves adhesion of vinyl by enhancing the bond between adhesive on the vinyl and the substrate, for a more durable, long-lasting application
- » Comes in an aerosol spray can for quick and easy application
- » A single can coats approximately 5 individual parts

MD3 Adhesion Promoter	842	\$16
-----------------------	-----	------



SCAN HERE TO  SHOP ONLINE

» FOR INDIVIDUAL BODY PANEL DIMENSIONS, VISIT FIVESTARBODIES.COM



PREMIUM UNIVERSAL PLASTIC FLAT SHEETS



- » Replace traditional aluminum with this extremely durable plastic
- » Resists chipping, denting, bending to last much longer than aluminum panels
- » Flame retardant with high heat distortion temperature
- » Trims easily with shears
- » Can be bent in a brake
- » .140" thick

**4'x8' & 3'x9.5' FLAT SHEETS
READY TO CUT & FIT!**

UNIVERSAL PLASTIC FLAT SHEETS

» Available in 5 colors **-W -B -G -CB -R**

4'x8' Sheet	30001-93051-x	\$142
3'x9.5' Sheet	30001-93151-x	\$125

» REPLACE TRADITIONAL ALUMINUM WITH OUR HIGH-IMPACT PLASTIC!

PRICING SUBJECT TO CHANGE WITHOUT NOTICE

NORTHEAST MODIFIED

NEW PLASTIC DOOR & QUARTER PANELS



UNMATCHED DURABILITY FOR THE BEASTS OF THE NORTHEAST



THE PREMIER BODY PANELS IN DIRT RACING

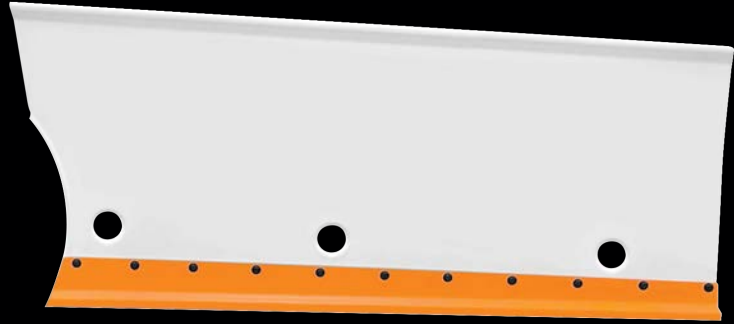

PLASTIC DOORS

Door, left	34200-21051-xL	\$149
Door, right	34200-21051-xR	\$149

PLASTIC QUARTER PANELS

Quarter Panel, left	34200-27351-xL	\$119
Quarter Panel, right	34200-27351-xR	\$119

- » Exclusive MD3 molded plastic panels provide unmatched durability
- » Repeatable flange fit panels for easy installation and replacement
- » Molded wheel well & nerf bar mounting holes
- » Meets all flame resistance test requirements
- » Approved for competition by all major national sanctioning series
- » Available in 5 colors **-W -B -G -CB -R**

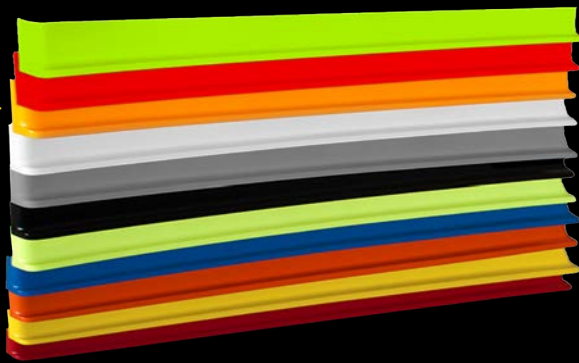

PLASTIC ROCKER PANEL

- » Aerodynamically designed for the best side force
- » These 77-3/4" x 7-1/4" lightweight, high-impact plastic rockers are aerodynamically designed for the best side force
- » They are easy to mount & add structural integrity to side body panels
- » Available in 11 colors

	-W -B -G -CB -R -Y -OR	-FG -FO -FR -FY
Rocker Panel	007-5500-x	\$40EA \$46EA

MD3 ADHESION PROMOTER

- » Specifically engineered adhesion promoter assures proper paint bonding to our special plastic
- » Other automotive grade primers on the market may not work at all or cause severe paint flaking
- » Improves adhesion of vinyl by enhancing the bond between adhesive on the vinyl and the substrate, for a more durable, long-lasting application
- » Comes in an aerosol spray can for quick and easy application
- » A single can coats approximately 5 individual parts

MD3 Adhesion Promoter	842	\$16
-----------------------	-----	------



ENGINEERED THROUGH THE DRIVER'S EYES



STOCK CAR

THE FUTURE OF STOCK CAR RACING STARTS HERE

Engineered with precision, this body features fully molded plastic quarter panels, enhanced aerodynamics & a design that mimics the factory Camaro.

This body is built for outstanding performance on both dirt & pavement.





- » Innovative 2-piece composite roof with integrated windshield, A-post & cowl
- » Engineered thicker-gauge plastic panels for superior strength & durability
- » Consistent, repeatable fit ensures effortless installation & replacement
- » Achieve maximum vinyl adhesion by using MD3 Adhesion Promoter
- » Great for both dirt and pavement racing
- » Fits all metric style chassis
- » Available in Black & White, with optional Blue or Red nose & bumper cover



CONNECT WITH TEAM FIVE STAR | FIVESTARBODIES.COM    

MD3 STOCK CAR

EXCLUSIVE FEATURES & HIGHLIGHTS

REALISTIC FACTORY
CAMARO APPEARANCE

2-PIECE COMPOSITE ROOF WITH
BUILT IN COWL THAT WILL
MOUNT TO FIREWALL

COMPOSITE HOOD
2 OPTIONS: STANDARD
& COPO

HIGH-IMPACT
PLASTIC NOSE



ALUMINUM DOORS

NEW HIGH FLOW LASER CUT ALUMINUM GRILL SCREEN

"WE ARE THRILLED TO BRING THIS NEW INNOVATIVE DESIGN TO THE IMCA STOCK CAR DIVISION, THE COLLABORATION WITH FIVE STAR BODIES HAS BEEN INSTRUMENTAL IN BRINGING THIS PROJECT TO LIFE. THEIR EXPERTISE AND DEDICATION HAVE BEEN INVALUABLE THROUGHOUT THIS PROCESS."

» BRETT ROOT, PRESIDENT OF IMCA

» MD3 IS THE PREMIER LINE OF DIRT RACING BODY PANELS!

MD3 STOCK CAR

EXCLUSIVE FEATURES & HIGHLIGHTS



ALUMINUM DECK LID

HIGH-IMPACT PLASTIC ONE PIECE QUARTER PANELS THAT MOUNT TO ROOF

OPTIONAL POLYCARBONATE QUARTER WINDOW WITH BLACKOUT BORDER

HIGH-IMPACT PLASTIC FENDERS

HIGH-IMPACT PLASTIC ROCKER PANELS

HIGH-IMPACT PLASTIC TAIL

PANELS MADE WITH THICKER GAUGE PLASTIC FOR SUPERIOR STRENGTH & DURABILITY!

ACHIEVE MAXIMUM VINYL ADHESION BY USING MD3 ADHESION PROMOTER. DETAILS AND ORDERING INFORMATION ON PAGE 167!



PRICING SUBJECT TO CHANGE WITHOUT NOTICE

MD3 STOCK CAR

BODY PANELS & OPTIONS

THE FUTURE OF STOCK CAR RACING STARTS HERE

COMPLETE BODY PACKAGE

-W -B

Bumper Cover, Rear, high-impact plastic	-W -B -CB -R	33131-45051-X	\$169
Deck Lid, aluminum		33131-31033-X	\$55
Door, aluminum, left		33131-21033-XL	\$148
Door, aluminum, right		33131-21033-XR	\$148
Fender, high-impact plastic, left		33131-23051-XL	\$169
Fender, high-impact plastic, right		33131-23051-XR	\$169
Hood, composite		33131-33211-X	\$390
Nose, high-impact plastic	-W -B -CB -R	33131-41051-X	\$240
Quarter Panel, high-impact plastic, left		33131-27151-XL	\$268
Quarter Panel, high-impact plastic, right		33131-27151-XR	\$268
Rocker Panel, high-impact plastic (2 REQUIRED) SPECIFY COLOR:	-W -B -CB -OR -R -Y -FG -FO -FR -FY	007-5500-X	\$40
Rocker Panel, high-impact plastic (ENTERED TWICE TO SHOW PACKAGE PRICE)	-W -B -CB -OR -R -Y -FG -FO -FR -FY	007-5500-X	\$40
Roof, front, composite		33131-51311-X	\$413
Roof, rear, composite		33131-51511-X	\$373
RE-SKIN BODY PACKAGE PRICE		33131-10600-x	\$2,890



ALL NEW AGGRESSIVE
AERODYNAMIC DESIGN

EXTREMELY DURABLE
HIGH-IMPACT PLASTIC
NOSE & FENDERS

BODY PACKAGE ACCESSORIES

Hood Filler Panel, high-impact plastic	33131-35851-X	\$52
Deck Lid Filler Panel, Complete	33131-32011-X	\$126
Deck Lid Bracket	33131-75631	\$32
Front Bumper, 1-3/4" round, .095" steel	33131-71185	\$48
Graphics, Bumper Cover ID Kit	33131-44541	\$36
Graphics, Nose ID Kit	33131-44141	\$37
Hood Pin Bracket, 3/4" steel (4 pins required)	33131-34331	\$39
Nose Screen, laser cut aluminum	33131-46533	\$50
Nose Screen, laser cut aluminum, black	33131-46533-B	\$55
Rear Bumper, 1-3/4" round, .065" steel	33131-71682	\$48
Rear Deck Mounting Kit	33131-72931	\$89
Windows, Quarter, mar-resistant coated, 0.093", left	33131-65153L	\$65
Windows, Quarter, mar-resistant coated, 0.093", right	33131-65153R	\$65

BODY DIMENSIONS

Make sure your body aligns accurately to maximize its performance and pass tech inspection successfully!
 Modern Style Nose Body dimensions match up with '88 Monte Style Nose Body dimensions

WIDTHS

A	B	C	D
OUTSIDE TO OUTSIDE	DOOR TO DOOR WIDTH	DOOR TO DOOR WIDTH	OUTSIDE TO OUTSIDE
75" MAX	53-1/4" MIN	57-3/4" MAX	74" MIN <small>(MEASURED AT THE BOTTOM OF WHEEL OPENING)</small>

ROOF HIGH POINT: Measured 29 1/2" back from top of windshield.

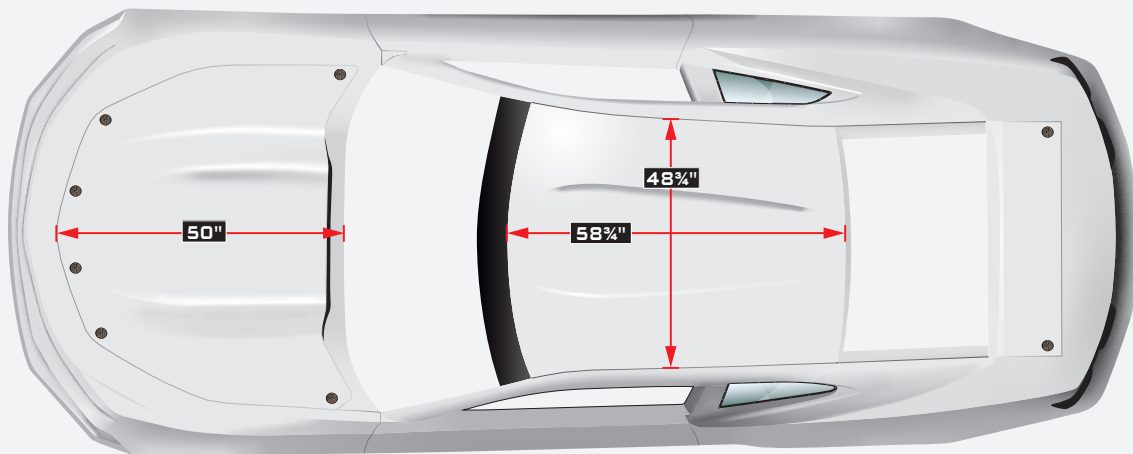
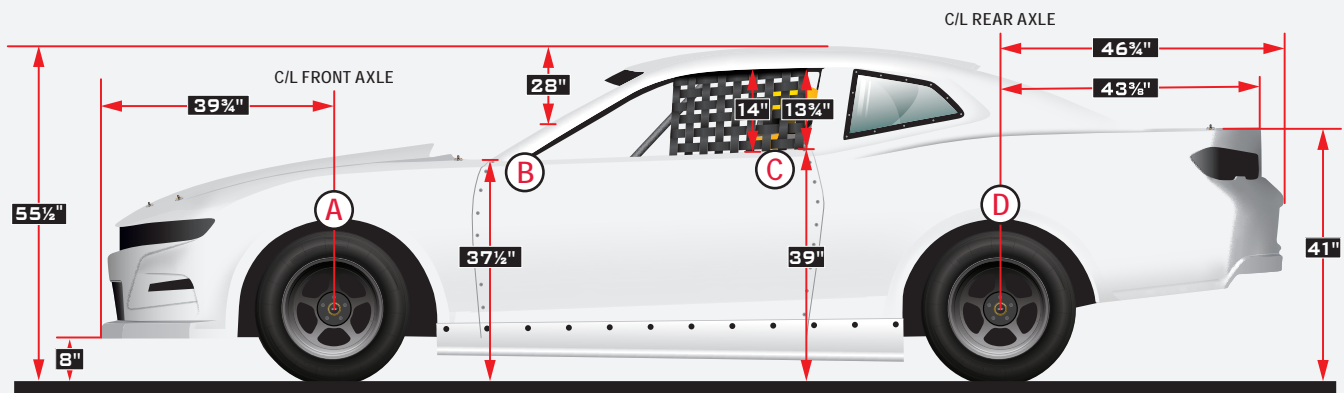

CHASSIS	ROOF HEIGHT	TREAD WIDTH	WHEELBASE
METRIC	55-1/2"	63" MAX	108"



» FOR INDIVIDUAL BODY PANEL DIMENSIONS, VISIT FIVESTARBODIES.COM

» FOR BODY MOUNTING TOOLS, GO TO PAGES 144-167

PRICING SUBJECT TO CHANGE WITHOUT NOTICE

ENGINEERED THROUGH THE DRIVER'S EYES



STREET STOCK

THE MOST VERSATILE BODY ON THE MARKET

The Street Stock Body features a timeless design that has consistently demonstrated its versatility, making it a reliable & long-lasting choice for top racers at short tracks across the country.





- » Replace old, hard-to-find junkyard panels to our complete line of body panels
- » Upgrade to a modern look with Camaro & Mustang nose, fenders, & hood options
- » '88 Monte Carlo panels designed to ensure stock appearance
- » Great for both dirt & pavement racing
- » Excellent fit, easy to install
- » See color options for all body panels & components in ordering section



STREET STOCK

BODY PANELS & OPTIONS

THE MOST VERSATILE BODY ON THE MARKET

» CHOOSE BETWEEN THE CLASSIC '88 MONTE CARLO OR THE MODERN STYLE LOOK

BODY STYLE OPTIONS

'88 Monte Carlo Style Body Panels		-W	-B	-CB	-OR	-R	-Y	-G
Bumper Cover, high-impact plastic	021-450-x							\$164
Bumper Cover ID Kit	021-450-ID							\$38
Nose, high-impact plastic (SPECIFY MAKE: CLASSIC-600 (N/A ORANGE OR YELLOW); MD3-021)	xxx-410-x							\$164
Nose ID Kit (SPECIFY MAKE: CLASSIC-600; MD3-021)	xxx-410-ID							\$39
Hood, composite, flat	601-3301-W							\$320
Hood, composite, scooped	601-3303-W							\$320
Modern Style Body Panels		-W	-B	-CB	-R			
Nose, high-impact plastic (SPECIFY MAKE: CAMARO-20132; MUSTANG-20321; CAMRY-20712)	2xxx-41051-x							\$177
Nose ID Kit (SPECIFY MAKE: CAMARO-20132; MUSTANG-20321; CAMRY-20712)	2xxx-44141							\$39
Fender, half, high-impact plastic, left or right	20002-23051-xLorR							\$116
Fender, full, high-impact plastic, left	11002-23051-xL							\$150
Fender, full, high-impact plastic, right	13002-23051-xR							\$150
Hood, composite, scooped	20002-33311-x							\$320

COMMON BODY PANEL OPTIONS

		-W	-B
Fender, Factory Outer Skin, steel, left	601-24SL	N/A	\$135
Fender, Factory Outer Skin, steel, right	601-24SR	N/A	\$135
Fender, Lower, aluminum, left or right	601-23A-WLorR	\$88	N/A
Fender, Lower, steel, left or right	601-23S-WLorR	\$88	N/A
Quarter Panel, Factory Outer Skin, steel, left or right	601-28SLorR	N/A	\$259
Quarter Panel, Lower, steel, left or right	601-27S-WLorR	\$105	N/A
Quarter Panel, Lower, aluminum, left or right	601-27A-WLorR	\$105	N/A
Door, aluminum, left or right	601-21A-WLorR	\$145	N/A
Door, aluminum, extra-long, left or right	601-211A-WLorR	\$145	N/A
Door, steel, left or right	601-21S-WLorR	\$145	N/A
Door, steel, left or right, IMCA-legal	601-22S-WLorR	\$145	N/A
Door, steel, extra-long, left or right	601-211S-WLorR	\$145	N/A
Deck Lid, aluminum	601-310A-W	\$65	N/A
Deck Lid, steel	601-310S-W	\$65	N/A
Deck Lid Filler Panel, composite	601-3200-W	\$189	N/A
Deck Lid Filler Panel, steel	601-320S-W	\$99	N/A
Roof, front, composite (SEE PAGE 99 FOR DETAILS)	601-5112-W	\$349	N/A
Roof, rear, standard, composite (SEE PAGE 99 FOR DETAILS)	601-5102-W	\$195	N/A
Roof, rear, long, composite (SEE PAGE 99 FOR DETAILS)	601-5104-W	\$195	N/A
2-piece Spoiler, aluminum	601-6702	\$48	N/A
Windshield, blank, coated, 32" X 72" X 1/8"	000-6301	\$136	N/A
Windshield Black-out Kit	600-6390	\$39	N/A

WINDOW OPTIONS

For the 2-Piece Composite Roof

Windshield, flat, coated, 1/8"	601-6303-2B	\$283	N/A
Windows, Quarter, flat, uncoated, pair, .093"	601-6502-2B	\$58	N/A
Window, Rear, uncoated, .093"	601-6101-2	\$76	N/A

For the Factory Stock Roof

Windshield, flat, coated, 1/8", no black-out	600-6303	\$233	N/A
Windows, Quarter, flat, uncoated, pair, .093"	600-6502	\$32	N/A
Window, Rear, flat, uncoated, .093"	600-6101	\$61	N/A
Windows Rear, coated, Aero Coupe, 1/8"	604-6125-A	\$371	N/A

*ALL WINDOWS ARE PRECUT TO FIT, BEVELED & DRILLED, WITH BLACK-OUT BORDER UNLESS OTHERWISE SPECIFIED.

2-PIECE COMPOSITE ROOF

- » Made from Standard Fiberglass Composite (lighter than factory steel)
- » Exact factory OEM shape with attached a-posts & cowl panel
- » Front roof has full molded in windshield bed
- » Rear roof available in 2 different lengths:
 - » **Standard** - fits up to a 108" wheelbase
 - » **Extra-long** - fits up to a 112" wheelbase (uses extra-long doors)

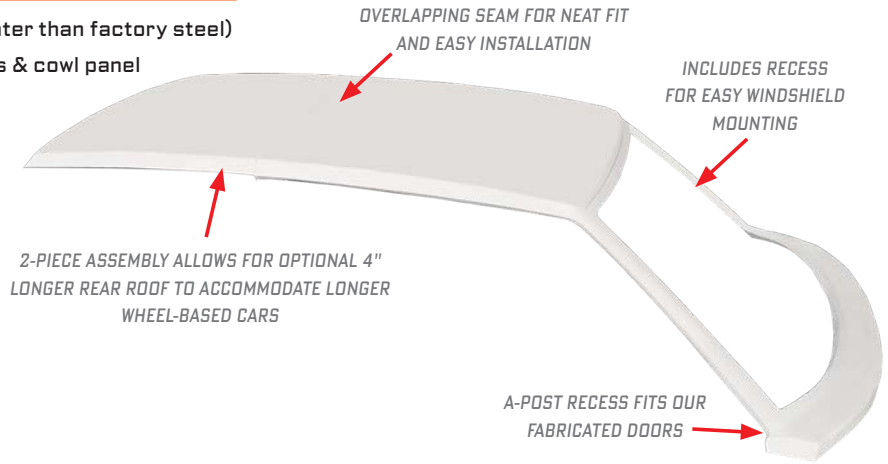

STREET STOCK DIMENSIONS

Make sure your body aligns accurately to maximize its performance and pass tech inspection successfully!
Modern Style Nose Body dimensions match up with '88 Monte Style Nose Body dimensions

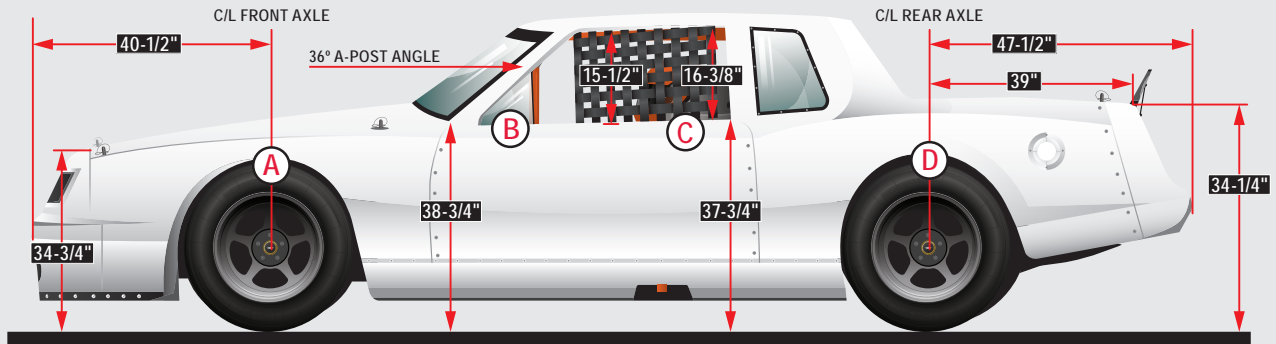

- WIDTHS**
- A** 71"
Outside to Outside:
Measured at front wheel opening
 - B** 65"
Door to Door Width: Measured at
A-posts and outside edge of doors,
measured through car
 - C** 65-1/2"
Door to Door Width: Measured at
B-posts and outside edge of
doors, measured through car
 - D** 65-1/2"
Outside to Outside:
Measured at rear wheel opening

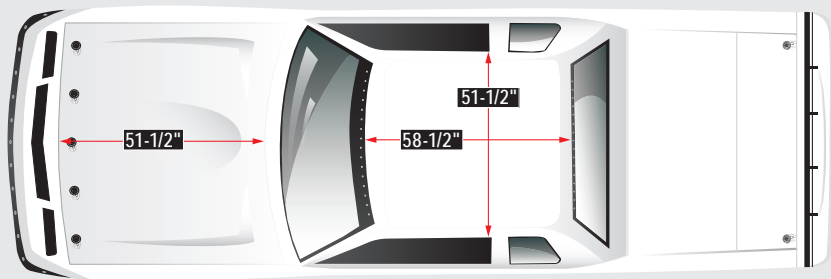

CHASSIS	ROOF HEIGHT	TREAD WIDTH	WHEELBASE
METRIC	52"	63" MAX	108"



» FOR INDIVIDUAL BODY PANEL DIMENSIONS, VISIT FIVESTARBODIES.COM

» FOR BODY MOUNTING TOOLS, GO TO PAGES 144-167

PRICING SUBJECT TO CHANGE WITHOUT NOTICE

STREET STOCK

FEATURED BODY ACCESSORIES

AIR FILTER DEFLECTORS:

- » Lightweight, high-impact molded plastic deflectors have a sleek aerodynamic design that provides maximum air filter protection
- » Three options to choose from, 3", 5", and 6" height
- » For more details & ordering info, see page 77



PLASTIC ROCKER PANEL:

- » Aerodynamically designed for the best side force
- » They are easy to mount & add structural integrity to side body panels
- » For more details & ordering info, see page 74

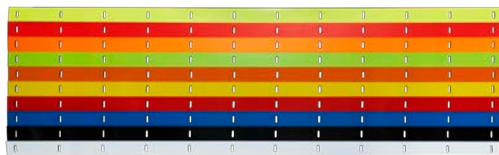
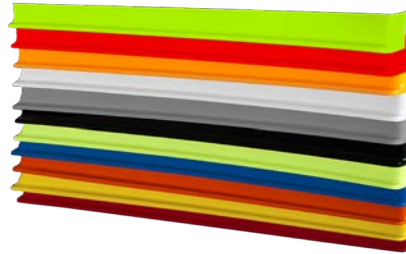

HIGH-IMPACT PLASTIC WEAR STRIPS:

- » Height adjustable to seal the nose to the track to optimize aero and protection from wear
- » CNC-machined from Five Star's exclusive durable plastic
- » For more details & ordering info, see page 147



PREMIUM AVEX STYLE RIVETS:

- » Five Star Premium Rivets are known as the best quality on the market
- » Grip range up to 3/16" for 1/8" rivets & up to 1/2" for 3/16" rivets
- » Super-tight grip & won't spin out while drilling!
- » For more details & ordering info, see page 146

» GO TO PAGES 144-167 TO SEE ALL ACCESSORIES FOR THIS BODY STYLE

STREET STOCK

GRAPHIC KITS & NOSE SCREENS

VINYL NOSE & BUMPER COVER GRAPHIC ID KITS FOR A REALISTIC OEM LOOK!

PRINTED ON OUTDOOR DURABLE HIGH-TACK VINYL • GLOSSY LAMINATED SURFACE PROVIDES EXCELLENT PROTECTION



CHEVROLET CAMARO

Nose ID Kit 20132-44141 \$39



FORD MUSTANG

Nose ID Kit 20321-44141 \$39



TOYOTA CAMRY

Nose ID Kit 20712-44141 \$39



CLASSIC '81-'88 MONTE CARLO

Nose ID Kit 600-410-ID \$39



MD3 '81-'88 MONTE CARLO

Nose ID Kit 021-410-ID \$39



'81-'88 MONTE CARLO

Bumper Cover ID Kit 021-450-ID \$38

ACHIEVE MAXIMUM VINYL ADHESION BY USING MD3 ADHESION PROMOTER. DETAILS AND ORDERING INFORMATION ON PAGE 167!



PROTECT YOUR RADIATOR FROM DEBRIS PENETRATION WITH NOSE SCREENS!



CLASSIC 81-88 MONTE CARLO, LOWER PN: 600-4111



MD3 81-88 MONTE CARLO, UPPER PN: 021-4131

ALUMINUM NOSE SCREENS

- » Frame is laser cut from lightweight aluminum
- » Screen is high strength stainless steel (3/16" mesh is crimped, 1/4" is welded)
- » Available options: unpainted or with durable satin black powder-coated finish

PN	NOSE SCREEN DESCRIPTION	WIDTH (Top)	WIDTH (Bottom)	HEIGHT	MESH	
660-4111	Common, Lower	27-3/4"	27-3/4"	7-1/4"	3/16"	\$50
660-4111-B	Common, Lower, Black	27-3/4"	27-3/4"	7-1/4"	3/16"	\$55
660-4112	Common, Lower	27-3/4"	27-3/4"	7-1/4"	1/4"	\$50
660-4112-B	Common, Lower, Black	27-3/4"	27-3/4"	7-1/4"	1/4"	\$55
021-4131	MD3 81-88 Monte Carlo, Upper	30-3/4"	29"	5-1/2"	3/16"	\$50
021-4131-B	MD3 81-88 Monte Carlo, Upper	30-3/4"	29"	5-1/2"	3/16"	\$55
021-4132	MD3 81-88 Monte Carlo, Upper	30-3/4"	29"	5-1/2"	1/4"	\$50
600-4111	Classic 81-88 Monte Carlo, Lower	28-1/4"	28-1/4"	5-3/4"	3/16"	\$50
600-4112	Classic 81-88 Monte Carlo, Lower	28-1/4"	28-1/4"	5-3/4"	1/4"	\$50
600-4131	Classic 81-88 Monte Carlo, Upper	30"	30"	6"	3/16"	\$50
600-4132	Classic 81-88 Monte Carlo, Upper	30"	30"	6"	1/4"	\$50

PRICING SUBJECT TO CHANGE WITHOUT NOTICE

ENGINEERED THROUGH THE DRIVER'S EYES



TA2 ROAD RACING

EXCLUSIVELY DESIGNED FOR TRANS AM COMPETITION

Constructed from premium composite materials, the TA2 Body
is the perfect combination of a stock appearance
and top-tier performance on the track.





NEW TOYOTA CAMRY BODY COMING SOON!

- » Tremendous shear (tear) resistance to withstand impact & prevent body debris
- » The Camaro & Mustang come with a narrow option for European competition
- » Body made of Advanced Lightweight Composite & Ultraglass
- » Flange-fit panels fit flush with no exposed fasteners
- » Repeatable fit for ease of replacement
- » White finish on all parts

CONNECT WITH TEAM FIVE STAR | FIVESTARBODIES.COM    

TA2 CAMARO

BODY PANELS & OPTIONS

ORDER YOUR BODY THROUGH AN AUTHORIZED DEALER » PAGE 109

**NOTE: TRANS AM CONTROLS DISTRIBUTION OF ALL TA2 BODY PANELS.
ALL PANEL ORDERS MUST GO THROUGH A FIVE STAR TA2 AUTHORIZED DEALER.**

COMPLETE BODY PACKAGE

Deck Lid, Ultraglass	81131-31013	*CALL
Door, Ultraglass, left or right	81131-21013LorR	*CALL
Fender, Ultraglass, left or right	81131-23013LorR	*CALL
Greenhouse, Front, advanced lightweight composite	81131-51312	*CALL
Greenhouse, Rear, advanced lightweight composite	81131-51512	*CALL
Hood, advanced lightweight composite	81131-33012	*CALL
Nose, Upper, advanced lightweight composite	81133-41212	*CALL
Nose, Lower, advanced lightweight composite, common	81001-41112	*CALL
Quarter Panel, Ultraglass, left or right	81131-27313LorR	*CALL
Rear Bumper Cover, advanced lightweight composite	81131-45012	*CALL
Quarter Window, 1/8", coated, black-out border, left or right	81131-65243LorR	\$62 ea
Rear Window, 1/8", coated, black-out border	81131-61243	\$461
Windshield, 3/16", coated, cut, bev, drilled, black-out border	81131-63343	\$510
COMPLETE BODY PACKAGE PRICE		*CALL

*ALL WINDOWS ARE PRECUT TO FIT, BEVELED & DRILLED, WITH BLACK-OUT BORDER UNLESS OTHERWISE SPECIFIED.

TO ENHANCE YOUR BODY PACKAGE, CHOOSE FROM THE OPTIONS BELOW:

BODY PACKAGE OPTIONS & UPGRADES

Door, increased access, upper, Ultraglass, left	81131-21713L	*CALL
Door, increased access, lower, Ultraglass, left	81131-21813L	*CALL
Fender, narrow, Ultraglass, left or right	81132-23013LorR	*CALL
Quarter Panel, narrow, Ultraglass, left or right	81132-27313LorR	*CALL
Nose, Lower, narrow, advanced lightweight composite, common	81002-41112	*CALL
Nose, Lower, high-impact plastic	81001-41151-W	*CALL
Nose, Upper, narrow, advanced lightweight composite	81132-41212	*CALL
Nose, Upper, high-impact plastic	81131-41251-W	*CALL
Vent Window Kit, .093" coated, cut polycarbonate pieces & aluminum brackets	81001-66122	*CALL

VINYL NOSE & BUMPER COVER GRAPHIC ID KITS FOR A REALISTIC OEM LOOK!

PRINTED ON OUTDOOR DURABLE HIGH-TACK VINYL • GLOSS LAMINATED SURFACE PROVIDES EXCELLENT PROTECTION



CHEVROLET CAMARO

Nose ID	81131-44142	\$42
Nose ID, 2018	81131-44141	\$42
Bumper Cover ID	81131-44541	\$29



TA2 CAMARO

DIMENSIONS & TEMPLATES

FIVE STAR BODIES ARE DESIGNED TO MAINTAIN PRECISE FIT WITH OPTIMIZED AERODYNAMICS!

CHEVROLET CAMARO: WIDTHS

A	B	C	D
79" MAX	77" MIN	79" MAX	74" MIN (measured at the bottom of wheel opening)

ROOF HIGH POINT: Measured 23" back from top of windshield. *The distance from the center line of the rear axle to the rear of the bumper cover is different on the Camaro & Mustang. However, the distance from the center line of the rear axle to the rear of the deck lid is the same on both body styles.
 Measured at the intersection of the hood and nose at centerline. *Measured at the centerline.

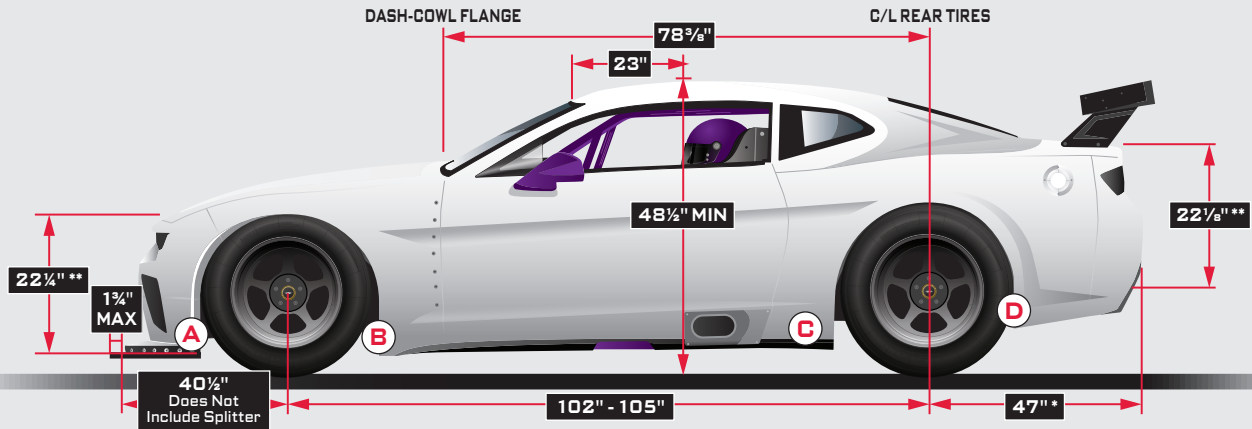

SCAN HERE TO SHOP ONLINE



» FOR INDIVIDUAL BODY PANEL DIMENSIONS, VISIT FIVESTARBODIES.COM

TA2 CAMARO TEMPLATES ENSURE A CORRECT FIT FOR OPTIMUM AERODYNAMICS

- » Templates ensure body is installed correctly
- » Nose Centerline templates are model specific
- » Body Centerline templates can check all models
- » Available in wood or aluminum
- » Master sets available with templates for all models

Template, Body Centerline, wood	81131-82191	\$40
Template, Nose Centerline, wood	81133-82491	\$23
Template, Body Centerline, aluminum	81131-82133	*CALL
Template, Nose Centerline, aluminum	81133-82433	*CALL

» FOR MORE BODY MOUNTING TOOLS, GO TO PAGES 144-167

PRICING SUBJECT TO CHANGE WITHOUT NOTICE

ABC LMSC TRUCK PAVMOD OUTLAW LATE MODEL SPORTSMAN OLDER BODIES MD3 LATE MODEL MD3 MODIFIED NORTHEAST MOD STOCK CAR STREET STOCK TA2 PRO STOCK/MOD FUNNY CAR JR ROADSTER WINDOWS ACCESSORIES

TA2 MUSTANG

BODY PANELS & OPTIONS

ORDER YOUR BODY THROUGH AN AUTHORIZED DEALER » PAGE 109

**NOTE: TRANS AM CONTROLS DISTRIBUTION OF ALL TA2 BODY PANELS.
ALL PANEL ORDERS MUST GO THROUGH A FIVE STAR TA2 AUTHORIZED DEALER.**

COMPLETE BODY PACKAGE

Deck Lid, Ultraglass	81321-31013	*CALL
Door, Ultraglass, left or right	81321-21013LorR	*CALL
Fender, Ultraglass, left or right	81321-23013LorR	*CALL
Greenhouse, Front, advanced lightweight composite	81321-51312	*CALL
Greenhouse, Rear, advanced lightweight composite	81321-51512	*CALL
Hood, advanced lightweight composite	81321-33012	*CALL
Nose, Upper, advanced lightweight composite	81321-41212	*CALL
Nose, Lower, advanced lightweight composite, common	81001-41112	*CALL
Quarter Panel, Ultraglass, left or right	81321-27313LorR	*CALL
Rear Bumper Cover, advanced lightweight composite	81321-45012	*CALL
Quarter Window, 1/8", coated, black-out border, left or right	81321-65243LorR	\$62 ea
Rear Window, 1/8", coated, black-out border	81321-61243	\$461
Windshield, 3/16", coated, cut, bev, drilled, black-out border	81321-63343	\$510
COMPLETE BODY PACKAGE PRICE		*CALL

*ALL WINDOWS ARE PRECUT TO FIT, BEVELED & DRILLED, WITH BLACK-OUT BORDER UNLESS OTHERWISE SPECIFIED.

TO ENHANCE YOUR BODY PACKAGE, CHOOSE FROM THE OPTIONS BELOW:

BODY PACKAGE OPTIONS & UPGRADES

Door, increased access, upper, Ultraglass, left	81321-21713L	*CALL
Door, increased access, lower, Ultraglass, left	81321-21813L	*CALL
Fender, narrow, Ultraglass, left or right	81322-23013LorR	*CALL
Quarter Panel, narrow, Ultraglass, left or right	81322-27313LorR	*CALL
Nose, Lower, narrow, advanced lightweight composite, common	81002-41112	*CALL
Nose, Lower, high-impact plastic	81001-41151-W	*CALL
Nose, Upper, narrow, advanced lightweight composite	81322-41212	*CALL
Nose, Upper, high-impact plastic	81321-41251-W	*CALL
Vent Window Kit, .093" coated, cut poly pieces & aluminum brackets	81001-66122	*CALL

VINYL NOSE & BUMPER COVER GRAPHIC ID KITS FOR A REALISTIC OEM LOOK!

PRINTED ON OUTDOOR DURABLE HIGH-TACK VINYL • GLOSS LAMINATED SURFACE PROVIDES EXCELLENT PROTECTION



FORD MUSTANG

Nose ID	81321-44141	\$42
Bumper Cover ID	81321-44541	\$29



TA2 MUSTANG

DIMENSIONS & TEMPLATES

FIVE STAR BODIES ARE DESIGNED TO MAINTAIN PRECISE FIT WITH OPTIMIZED AERODYNAMICS!

FORD MUSTANG: WIDTHS

A	B	C	D
79" MAX	77" MIN	79" MAX	74" MIN (measured at the bottom of wheel opening)

ROOF HIGH POINT: Measured 23" back from top of windshield. *The distance from the center line of the rear axle to the rear of the bumper cover is different on the Camaro & Mustang. However, the distance from the center line of the rear axle to the rear of the deck lid is the same on both body styles. **Measured at the intersection of the hood and nose at centerline. ***Measured at the centerline.

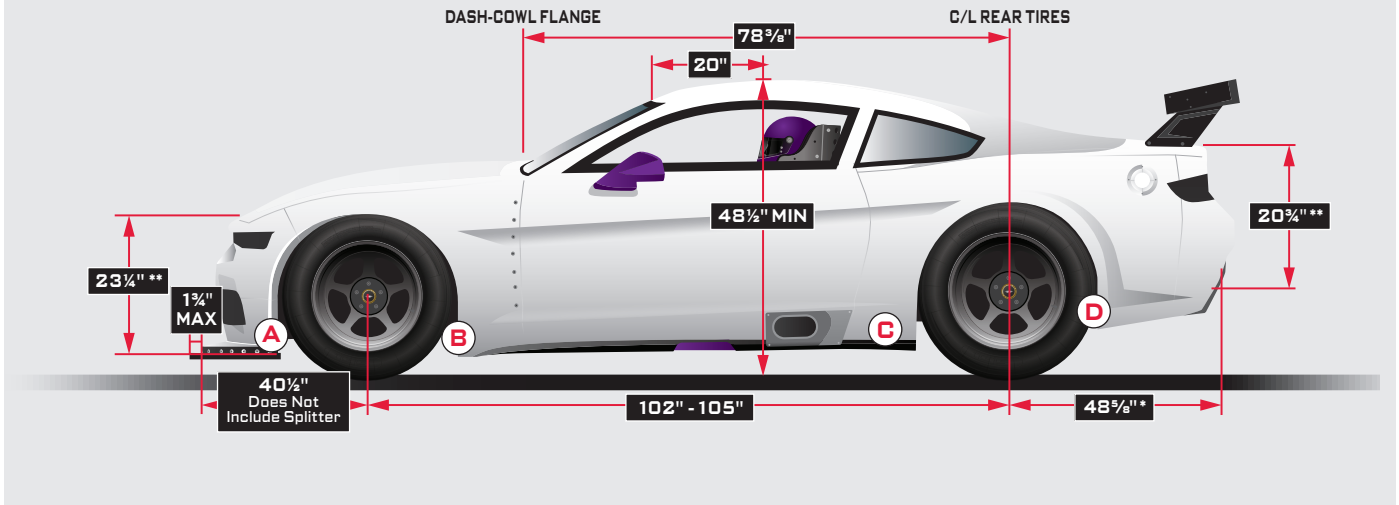

SCAN HERE TO SHOP ONLINE



» FOR INDIVIDUAL BODY PANEL DIMENSIONS, VISIT FIVESTARBODIES.COM

TA2 MUSTANG TEMPLATES ENSURE A CORRECT FIT FOR OPTIMUM AERODYNAMICS

- » Templates ensure body is installed correctly
- » Nose Centerline templates are model specific
- » Body Centerline templates can check all models
- » Available in wood or aluminum
- » Master sets available with templates for all models

Template, Body Centerline, wood	81321-82191	\$40
Template, Nose Centerline, wood	81321-82491	\$23
Template, Body Centerline, aluminum	81321-82133	*CALL
Template, Nose Centerline, aluminum	81321-82433	*CALL

» FOR MORE BODY MOUNTING TOOLS, GO TO PAGES 144-167

TA2 CHALLENGER

BODY PANELS & OPTIONS

ORDER YOUR BODY THROUGH AN AUTHORIZED DEALER » PAGE 109

**NOTE: TRANS AM CONTROLS DISTRIBUTION OF ALL TA2 BODY PANELS.
ALL PANEL ORDERS MUST GO THROUGH A FIVE STAR TA2 AUTHORIZED DEALER.**

COMPLETE BODY PACKAGE

Deck Lid, standard composite	81521-31011	*CALL
Deck Lid Filler Panel, standard composite	81521-32011	*CALL
Door, standard composite, left or right	81521-21011LorR	*CALL
Fender, standard composite, left or right	81521-23011LorR	*CALL
Greenhouse, Front, standard composite	81521-51311	*CALL
Greenhouse, Rear, standard composite	81521-51511	*CALL
Hood, advanced lightweight composite	81521-33012	*CALL
Nose, standard composite	81521-41011	*CALL
Quarter Panel, standard composite, left or right	81521-27311LorR	*CALL
Rear Bumper Cover, standard composite	81521-45011	*CALL
Quarter Window, 1/8", coated, black-out border, left or right	81521-65243LorR	\$48 ea
Rear Window, 1/8", coated, black-out border	81521-61243	\$388
Windshield, 3/16", coated, cut, bev, drilled, black-out border	81521-63343	\$422
COMPLETE BODY PACKAGE PRICE		*CALL

*ALL WINDOWS ARE PRECUT TO FIT, BEVELED & DRILLED, WITH BLACK-OUT BORDER UNLESS OTHERWISE SPECIFIED.

TO ENHANCE YOUR BODY PACKAGE, CHOOSE FROM THE OPTIONS BELOW:

BODY PACKAGE OPTIONS & UPGRADES

Door, increased access, upper, small, composites, left	81521-21711L	*CALL
Door, increased access, lower, large, composites, left	81521-21811L	*CALL

VINYL NOSE & BUMPER COVER GRAPHIC ID KITS FOR A REALISTIC OEM LOOK!

PRINTED ON OUTDOOR DURABLE HIGH-TACK VINYL • GLOSS LAMINATED SURFACE PROVIDES EXCELLENT PROTECTION



DODGE CHALLENGER

Nose ID	81521-44141	\$42
Bumper Cover ID	81521-44541	\$29

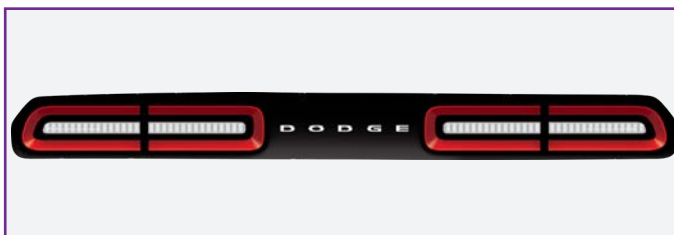

TA2 CHALLENGER

DIMENSIONS & TEMPLATES

FIVE STAR BODIES ARE DESIGNED TO MAINTAIN PRECISE FIT WITH OPTIMIZED AERODYNAMICS!

DODGE CHALLENGER: WIDTHS

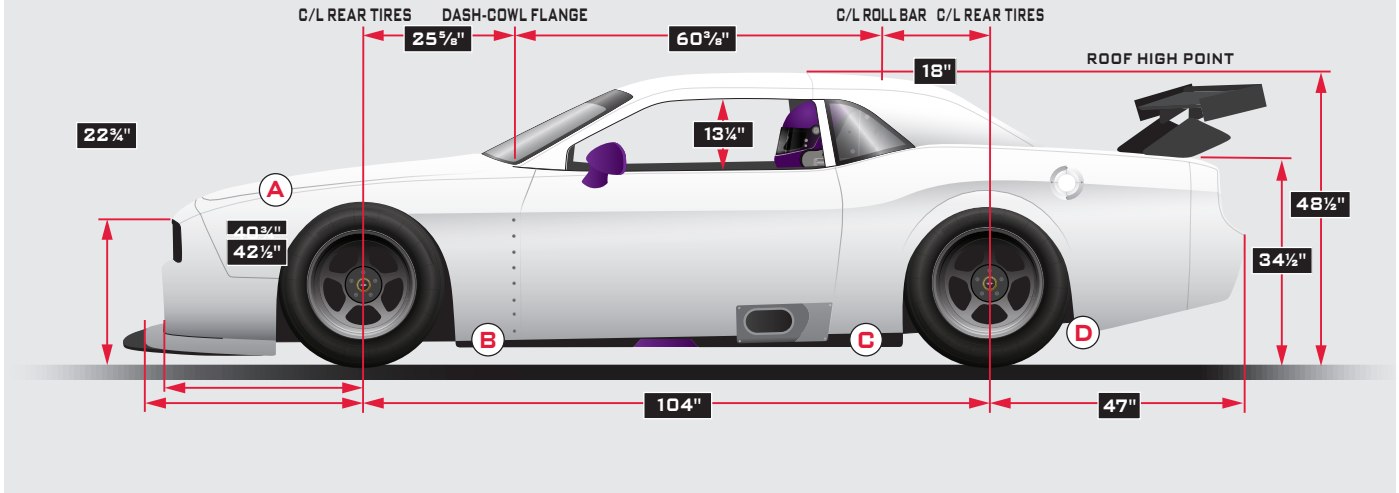

» FOR MORE BODY MOUNTING TOOLS, GO TO PAGES 144-167



» FOR INDIVIDUAL BODY PANEL DIMENSIONS, VISIT FIVESTARBODIES.COM

AUTHORIZED FIVE STAR TA2 BODY DEALERS

HOWE RACING ENTERPRISES

3195 LYLE ROAD
BEAVERTON, MI 48612
PH: (989) 435-7080
HOWERACING.COM

JEFFERSON RACE CARS

1660 STATE ROUTE 410
NACHES, WA 98937
PH: (509) 952-6233
JEFFERSON-RACING.COM

MIKE COPE RACING ENTERPRISES, INC.

11692 56TH COURT NORTH
CLEARWATER, FL 33760
PH: (727) 201-8910
MIKECOPERACECARS.COM

M1-SLR

71 CARRERA STREET
ST. AUGUSTINE, FL 32084
PH: (704) 746-7264
TEAMSLR.COM/M1-RACECARS

TA2 ROAD RACE

FEATURED BODY ACCESSORIES

ALUMINUM WINDOW BRACES

- » Strongest window braces on the market
- » Designed to the exact contour of your Five Star windows
- » Made of premium high-strength aluminum with flat black powder-coated finish
- » Foam-padded surface won't scratch your windows
- » Pre-drilled holes to mount adjustable bracing from the interior dash
- » **Kit includes:** 3 aluminum braces and weighs less than 2 lbs

Front Braces, Chevrolet	26-1/8" x 1"	81131-76333	\$84
Rear Braces, Chevrolet	27-1/4" x 1"	81131-76133	\$84
Front Braces, Ford	28-1/4" x 1"	81321-76333	\$84
Rear Braces, Ford	34-7/8" x 1"	81321-76133	\$84



CHEVROLET WINDSHIELD BRACES

WEIGHS
7.3280Z



CHEVROLET REAR BRACES



LOWER NOSE SCREEN

- » Protects the radiator from debris penetration
- » Frame is laser cut from lightweight aluminum
- » Screen is high strength stainless steel (1/4" MESH IS WELDED)
- » Durable black powder-coated finish
- » Weighs only 10.32oz

Nose Screen, common	81001-464338	\$55
---------------------	--------------	------



POLYCARBONATE DOOR VENT WINDOWS

- » Vent windows give cars a proven performance gain in the wind tunnel
- » Precut to fit, mar-resistant coated, clear .093" polycarbonate
- » Laser cut aluminum mounting brackets

Precut-to-fit, set of 2	81001-66122	\$38
-------------------------	-------------	------

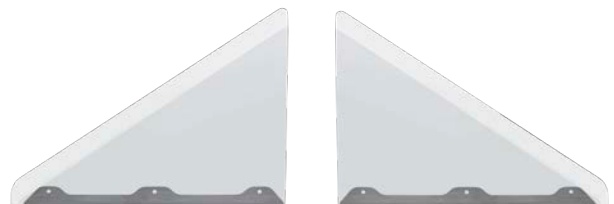

TA2 ROAD RACE

BODY ACCESSORIES

LOWER NOSE UNIVERSAL SPLITTER

- » 2 piece 5/16" thick black high-impact plastic material
- » CNC-routed mounting points
- » Weighs 21 lbs
- » Approved for use in Trans Am Racing Series

Splitter	81001-41851	\$118
----------	-------------	-------

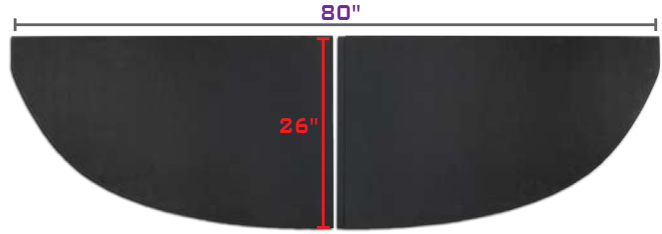

FRONT & REAR BUMPERS

- » Now formed using CNC progressive tube bending technology
- » Fits the exact contour of Five Star noses and bumper covers for maximum protection and ease of installation
- » Formed from 1-1/2" OD round steel tubing

Front, Chevrolet, .065" steel	81131-71162	\$48
Rear, Chevrolet, .065" steel	81131-71662	\$48
Front, Ford, .065" steel	81321-71162	\$48
Rear, Ford, .065" steel	81321-71662	\$48



ALUMINUM HOOD PIN BRACKETS

- » Pre-formed to fit the nose & hood precisely
- » 3/4" square option, & will work with our 3/8" hood pins

Bracket, Chevrolet	81131-34333	\$55
Bracket, Ford	81321-34333	\$55

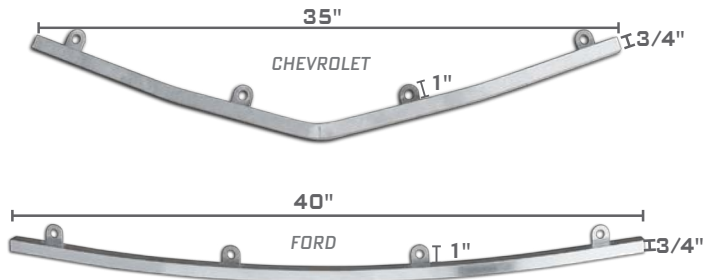

CONVEX RACING MIRROR

- » This convex glass mirror gives you the best view of your competition, includes a bracket kit for easy installation
- » All black frame with black anodized machined aluminum brackets
- » Only weighs 19 oz

Convex Glass Mirror	00001-85020	\$49
---------------------	-------------	------



ENGINEERED THROUGH THE DRIVER'S EYES



PRO STOCK / PRO MOD

ENGINEERED FOR MAXIMUM PERFORMANCE

The Pro Stock/Pro Mod body reigns as the preferred choice for top drag racers. It is meticulously engineered to deliver maximum performance on the drag strip, making it the ultimate selection for those seeking speed, precision & winning results.





- » Available in 3 composite blends:
- » **LIGHTWEIGHT COMPOSITE:** Body weighs under 80 lbs
- » **CARBON FIBER:** Body weighs under 70 lbs
- » **ULTRA LIGHT CARBON FIBER:** Body weighs under 60 lbs
- » Fits 105" to 115" wheelbase chassis
- » Gray ready to paint finish on all parts

CONNECT WITH TEAM FIVE STAR | FIVESTARBODIES.COM    

CAMARO BODY PANELS & OPTIONS

* CARBON FIBER BODY PANELS SOLD THROUGH CHEVROLET PERFORMANCE

» BILL SCHEMERS: 810.397.9688 EMAIL: BILL.S@TGIDIRECT.COM

PRO STOCK BODY PACKAGES	LIGHTWEIGHT COMPOSITE		*CARBON FIBER		*ULTRA LIGHT CARBON FIBER	
Dash	64131-90012	\$698	N/A	N/A	N/A	N/A
Deck Lid	64131-31012	\$401	64131-31017	*CALL	64131-31018	*CALL
Door, left	64131-21012L	\$1,018	64131-21017L	*CALL	64131-21018L	*CALL
Door, right	64131-21012R	\$1,018	64131-21017R	*CALL	64131-21018R	*CALL
Front Clip, 1-piece UP TO 105" WHEELBASE, SCOOPED	64132-43012	\$3,484	64132-43017	*CALL	64132-43018	*CALL
Front Clip, 1-piece UP TO 105" WHEELBASE, EFI	64132-43012-2	\$3,484	64132-43017-2	*CALL	64132-43018-2	*CALL
Rear Clip, 1-piece	64131-51712	\$4,167	64131-51717	*CALL	64131-51718	*CALL
Spoiler, Spill Plates	913-6700-SP	\$215	COS0604-SP	\$347	N/A	N/A
Spoiler, Wing	XC 962-6700L-W	\$385	XC 962-6700C-W	\$464	XC 962-6700U-W	\$480
PRO STOCK BODY PACKAGE PRICE	64131-10312	\$11,386	64131-10317	*CALL	64131-10318	*CALL

PRO MOD BODY PACKAGES	LIGHTWEIGHT COMPOSITE		*CARBON FIBER		*ULTRA LIGHT CARBON FIBER	
Dash	64131-90012	\$698	N/A	N/A	N/A	N/A
Deck Lid	64131-31012	\$401	64131-31017	*CALL	64131-31018	*CALL
Door, left	64131-21012L	\$1,018	64131-21017L	*CALL	64131-21018L	*CALL
Door, right	64131-21012R	\$1,018	64131-21017R	*CALL	64131-21018R	*CALL
Front Clip, 1-piece UP TO 115" WHEELBASE, SCOOPED	65132-43012	\$3,607	65132-43017	*CALL	65132-43018	*CALL
Front Clip, 1-piece UP TO 115" WHEELBASE, EFI	65132-43012-2	\$3,607	65132-43017-2	*CALL	65132-43018-2	*CALL
Rear Clip, 1-piece	64131-51712	\$4,167	64131-51717	*CALL	64131-51718	*CALL
Spoiler, Spill Plates	913-6700-SP	\$215	COS0604-SP	\$347	N/A	N/A
Spoiler, Wing	XC 962-6700L-W	\$385	XC 962-6700C-W	\$464	XC 962-6700U-W	\$480
PRO MOD BODY PACKAGE PRICE	65131-10312	\$11,509	65131-10317	*CALL	65131-10318	*CALL

IMPORTANT: LEAD TIMES MAY VARY. PRICE DOES NOT INCLUDE SHIPPING OR THE ADDITIONAL CRATING FEES APPLIED AT TIME OF PURCHASE FOR COMPLETE BODIES.

PRO STOCK / PRO MOD WINDOWS & HEADLIGHT LENS COVERS TINTED WINDOWS AVAILABLE ON OUR WEBSITE

Windshield, molded, mar-resistant coated, 3/16", OVERSIZED	64131-63302	\$397
Windshield, molded, mar-resistant coated, 3/16", cut to fit, beveled	64131-63332	\$472
Windshield, molded, mar-resistant coated, 1/8", OVERSIZED	64131-63202	\$382
Windshield, molded, mar-resistant coated, 1/8", cut to fit, beveled	64131-63232	\$409
Door Window, molded, mar-resistant coated, 1/8", OVERSIZED, left or right	64131-62202LorR	\$158 ea
Door Window, molded, mar-resistant coated, 1/8", cut to fit, beveled, left or right	64131-62232LorR	\$191 ea
Door Window, molded, mar-resistant coated, .093", OVERSIZED, left or right	64131-62102LorR	\$126 ea
Door Window, molded, mar-resistant coated, .093", cut to fit, beveled, left or right	64131-62132LorR	\$145 ea
Quarter Window, molded, mar-resistant coated, 1/8", cut to fit, beveled, drilled, left or right	64131-65242LorR	\$42 ea
Quarter Window, molded, mar-resistant coated, .093", cut to fit, beveled, drilled, left or right	64131-65142LorR	\$40 ea
Rear Window, molded, mar-resistant coated, 1/8", cut to fit, beveled, drilled	64131-61242	\$398
Rear Window, molded, mar-resistant coated, .093", cut to fit, beveled, drilled	64131-61142	\$264
Headlight Lens Covers, molded, mar-resistant coated polycarbonate, pair	60132-68142	\$72

VINYL NOSE & TAIL ID GRAPHIC ID KITS FOR A REALISTIC DEM LOOK!

PRINTED ON OUTDOOR DURABLE HIGH-TACK VINYL • GLOSS LAMINATED SURFACE PROVIDES EXCELLENT PROTECTION



CHEVROLET CAMARO

Nose ID	60131-44142	\$38
Tail ID	60131-44542	\$38

» FOR OLDER CAMARO PRO STOCK BODY PANELS, CALL OUR SALES TEAM

MUSTANG BODY PANELS & OPTIONS

HOW TO ORDER YOUR BODY IN 3 QUICK & EASY STEPS

» 1. SELECT BODY TYPE » 2. SPECIFY WITH OR WITHOUT SCOOP » 3. SELECT MATERIAL

PRO STOCK BODY PACKAGES	LIGHTWEIGHT COMPOSITE		CARBON FIBER		ULTRA LIGHT CARBON FIBER	
Dash	960-900L	\$698	N/A	N/A	N/A	N/A
Deck Lid	64321-31012	\$401	64321-31017	\$398	64321-31018	\$440
Door, left	64321-21012L	\$1,011	64321-21017L	\$1,076	64321-21018L	\$1,157
Door, right	64321-21012R	\$1,011	64321-21017R	\$1,076	64321-21018R	\$1,157
Front Clip, 1-piece UP TO 105" WHEELBASE, SCOOPED	64321-43012	\$3,202	64321-43017	\$4,085	64321-43018	\$4,754
Front Clip, 1-piece UP TO 105" WHEELBASE, EFI	64321-43012-2	\$3,202	64321-43017-2	\$4,085	64321-43018-2	\$4,754
Rear Clip, 1-piece	64321-51712	\$4,255	64321-51717	\$5,177	64321-51718	\$6,170
Spoiler, Spill Plates	913-6700-SP	\$215	CCS0604-SP	\$347	N/A	N/A
Spoiler, Wing	64321-48012	\$392	64321-48017	\$445	64321-48018	\$486
PRO STOCK BODY PACKAGE PRICE	64321-10312	\$11,185	64321-10317	\$13,302	64321-10318	\$15,209

PRO MOD BODY PACKAGES	LIGHTWEIGHT COMPOSITE		CARBON FIBER		ULTRA LIGHT CARBON FIBER	
Dash	960-900L	\$698	N/A	N/A	N/A	N/A
Deck Lid	64321-31012	\$401	64321-31017	\$398	64321-31018	\$440
Door, left	64321-21012L	\$1,011	64321-21017L	\$1,076	64321-21018L	\$1,157
Door, right	64321-21012R	\$1,011	64321-21017R	\$1,076	64321-21018R	\$1,157
Front Clip, 1-piece UP TO 115" WHEELBASE, SCOOPED	65321-43012	\$3,202	65321-43017	\$4,085	65321-43018	\$4,754
Front Clip, 1-piece UP TO 115" WHEELBASE, EFI	65321-43012-2	\$3,202	65321-43017-2	\$4,085	65321-43018-2	\$4,754
Rear Clip, 1-piece	64321-51712	\$4,255	64321-51717	\$5,177	64321-51718	\$6,170
Spoiler, Spill Plates	913-6700-SP	\$215	CCS0604-SP	\$347	N/A	N/A
Spoiler, Wing	64321-48012	\$392	64321-48017	\$445	64321-48018	\$486
PRO MOD BODY PACKAGE PRICE	65321-10312	\$10,086	65321-10317	\$12,206	65321-10318	\$14,071

IMPORTANT: LEAD TIMES MAY VARY. PRICE DOES NOT INCLUDE SHIPPING OR THE ADDITIONAL CRATING FEES APPLIED AT TIME OF PURCHASE FOR COMPLETE BODIES.

PRO STOCK / PRO MOD WINDOWS & HEADLIGHT LENS & TAIL LIGHT COVERS TINTED WINDOWS AVAILABLE ON OUR WEBSITE

Windshield, molded, mar-resistant coated, 3/16", OVERSIZED	64321-63302	\$379
Windshield, molded, mar-resistant coated, 3/16", cut to fit, beveled	64321-63332	\$406
Windshield, molded, mar-resistant coated, 1/8", OVERSIZED	64321-63202	\$353
Windshield, molded, mar-resistant coated, 1/8", cut to fit, beveled	64321-63232	\$383
Door Window, molded, mar-resistant coated, 1/8", OVERSIZED, left or right	64321-62202LorR	\$144 ea
Door Window, molded, mar-resistant coated, 1/8", cut to fit, beveled, left or right	64321-62232LorR	\$176 ea
Door Window, molded, mar-resistant coated, .093", OVERSIZED, left or right	64321-62102LorR	\$121 ea
Door Window, molded, mar-resistant coated, .093", cut to fit, beveled, left or right	64321-62132LorR	\$145 ea
Quarter Window, molded, mar-resistant coated, 1/8", cut to fit, beveled, drilled, left or right	64321-65242LorR	\$121 ea
Quarter Window, molded, mar-resistant coated, .093", cut to fit, beveled, drilled, left or right	64321-65142LorR	\$88 ea
Rear Window, molded, mar-resistant coated, 1/8", cut to fit, beveled, drilled	64321-61242	\$398
Rear Window, molded, mar-resistant coated, .093", cut to fit, beveled, drilled	64321-61142	\$242
Headlight Lens Covers, molded, mar-resistant coated polycarbonate, pair	60321-68142	\$52
Tail Light Covers, composites	64321-45417	\$275

VINYL NOSE & TAIL ID GRAPHIC ID KITS FOR A REALISTIC OEM LOOK!

PRINTED ON OUTDOOR DURABLE HIGH-TACK VINYL • GLOSS LAMINATED SURFACE PROVIDES EXCELLENT PROTECTION

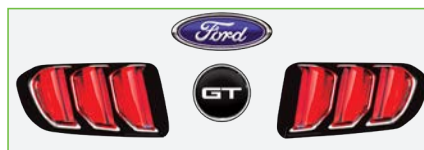

FORD MUSTANG

Nose ID	60321-44141	\$52
Tail ID	64321-44541	\$38

PRICING SUBJECT TO CHANGE WITHOUT NOTICE

PRO STOCK

BODY DIMENSIONS

NO.	LOCATION	DETAILS	CHEVROLET CAMARO SS	FORD MUSTANG
1.	Front Overhang	Measured from long side of wheelbase center to front edge of body (splitter not included)	45.00	45.00 max
2.	Width	Over spindle	64.75	64.75
3.	Front Fascia Width	Measured across the front end at upper/outer corners of headlight recessed area	51.00	30.875
4.	Windshield Length Center	Measured from top center of windshield down to rear of hood/cowl center	20.25 min	24.50 min
5.	Overall Height	Measurement taken from the highest point of roof to rear of rocker	44.00 min	44.00
6.	Width (at B-Post)	Measurement taken 15" up from bottom of rocker, +/-0.25"	65.75	65.00
7.	Roof Length		58.625	45.25
8.	Side Window Height	Measurement taken at tallest point	12.125	14.00
9.	Door Length	Measurement taken at upper body line	56.375	53.375
10.	Rear Window Length		27.25	35.75
11.	Deck Lid Length	Measurement taken from bottom of rear window center	18.125	19.75
12.	Deck Lid Width	Measurement taken across rear of deck lid	47.75	45.50
13.	Spoiler Length	Length does not include wicker height. Minimum 0.75" height for wicker. Must be 90°	14.00	14.00
14.	Windshield Length	Measurement taken 12" inward from bottom corner of windshield. From this point, go to top of windshield, parallel to center line of body	26.25 min	28.50 min
15.	Spill Plate Height	+/-0.125"	6.00	6.00
16.	Section of Spill Plate above Spoiler	+/-0.125"	1.00	1.00
17.	Spill Plate Extension past rear of Spoiler		2.00 max	2.00 max
18.	Width in Front of Front Tire	Measurement taken at bottom of opening. +/-0.25"	62.50	62.125
19.	Width Behind Front Tire	Measurement taken 10" from front of rocker. +/-0.25"	63.625	64.25
20.	Width at Front Edge of Door	Measurement taken at widest point, +/-0.25"	65.50	65.25
21.	Width in Front of Rear Tire	Measurement taken at bottom of rocker. +/-0.25"	65.75	65.50
22.	Width Behind Rear Tire	Measurement taken at bottom of panel, widest point, +/-0.25"	61.50	60.875
23.	Width at Center of Rear Axle	+/-0.25"	66.25	67.25
24.	Rear Overhang	Measurement taken from the center of the rear axle to the center of bumper at furthest point above wheelie bar opening, +/-0.25"	48.25	49.25
25.	Length Left Hand Side	Measurement taken from rear of rocker to front edge of front wheel opening. +/-0.25"	100.50	102.125
26.	Length Right Hand Side	Measurement taken from rear of rocker to front edge of front wheel opening. +/-0.25"	99.125	100.875
27.	Wheelbase - Max		105.00	105.00
28.	Wheelbase - Min		104.00	104.00
29.	B-Post to Centerline of rear axle	+/-0.25"	21.50	22.00
30.	Splitter Length	Amount of 2.375" Total length front splitter mounted in front of body (see NHRA rulebook for more info)	0.375	0.375
31.	Length of Spill Plate		26.00 max	26.00 max
32.	B-Post Location	Measurement taken from bottom of rocker	15.00	15.00

FIVE STAR BODIES ARE DESIGNED TO MAINTAIN PRECISE FIT WITH OPTIMIZED AERODYNAMICS!

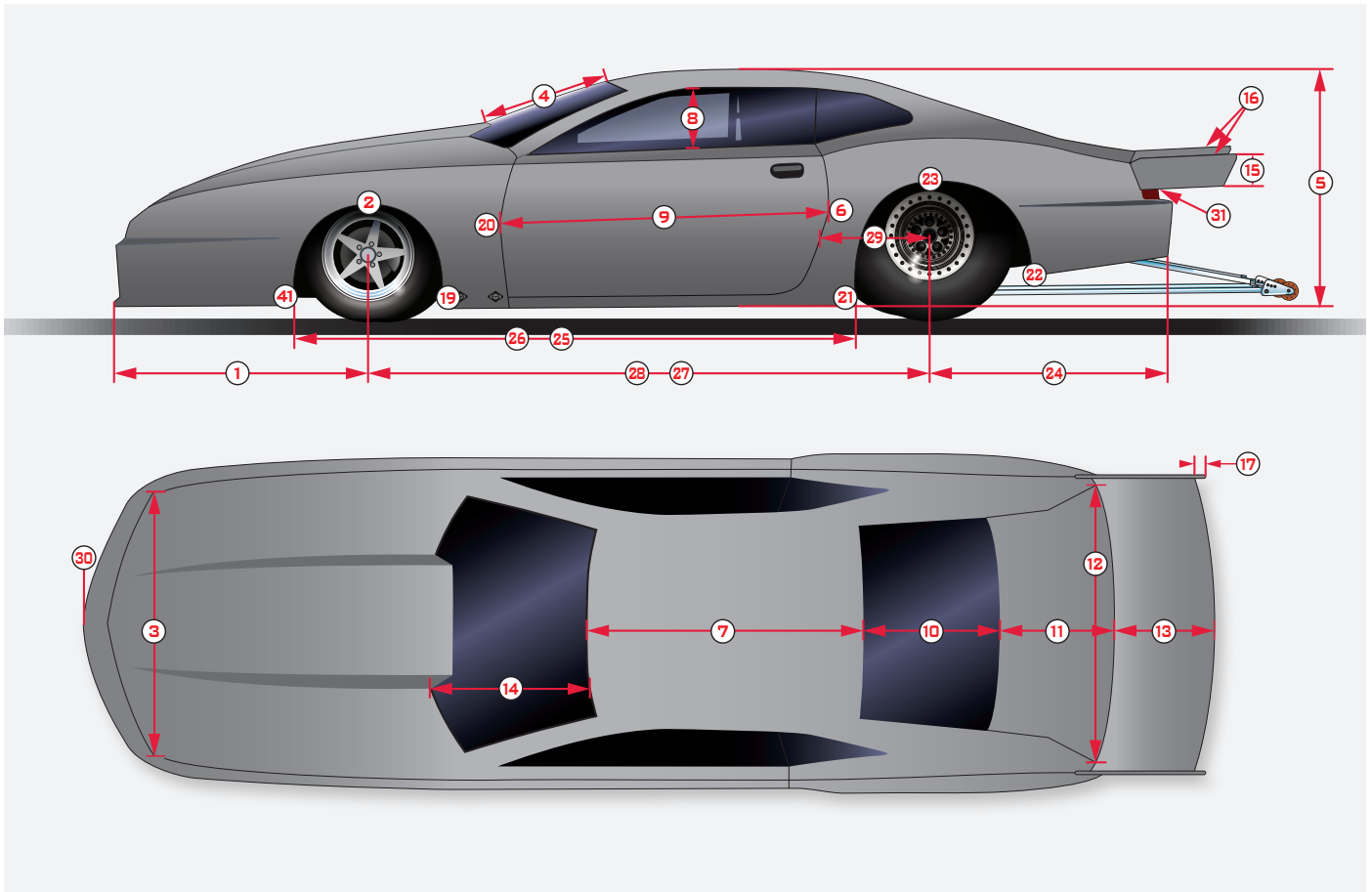

» **DOWNLOAD OFFICIAL RULEBOOK @ NHRARACER.COM**

HAVE A TECH QUESTION? THE NHRA ALSO HAS RESOURCES FOR ALL NHRA DIVISIONS TO ANSWER YOUR QUESTIONS ABOUT SAFETY, RULES & COMPLIANCE. VISIT NHRARACER.COM



TEMPLATE SETS ENSURE A CORRECT FIT FOR OPTIMUM AERODYNAMICS

- » Complete template set ensures body is installed correctly
- » Made from high-quality aluminum to maintain shape
- » Purchase complete set or Body/Nose Centerline only

Template Set, Ford, Complete, aluminum (ADDITIONAL CRATING CHARGE FOR FREIGHT SHIPMENT)	60321-82033	\$834
Template Set, Chevrolet, Complete, aluminum (ADDITIONAL CRATING CHARGE FOR FREIGHT SHIPMENT)	60132-82033	\$712
Template, Nose/Body Centerline, Chevrolet, aluminum	60132-82133	\$331

****PRICING SUBJECT TO CHANGE WITHOUT NOTICE****

PRO STOCK / PRO MOD

FEATURED PRODUCTS



WINDOW INSTALLATION KIT

- » Provides the perfect fit and helps to increase the life of your window
- » Black oxide coated to prevent rust
- » This kit has enough hardware to install a complete set of windows on one car
- » Kit includes: 120 6-32 1/2" & 16 6-32 3/4" flat head socket screws, 136 6-32 nylon locknuts, 1 long-arm hex key and 9/64" drill bit

Window Installation Kit	805	\$27
-------------------------	-----	------



VINYL NOSE & TAIL ID GRAPHIC ID KITS

Built to withstand the rigors of the racetrack, our vinyl graphics are made from high-quality materials that resist fading, cracking, and peeling. They maintain their brilliant appearance even under the harshest conditions.

- » **HIGH-TACK ADHESION:** Our outdoor high-tack vinyl ensures that your graphics stay securely in place
- » **EXTREME DURABILITY:** Gloss laminated surface provides excellent protection under the harshest conditions
- » **EASY APPLICATION:** Installing our graphics is a breeze. With our easy-to-follow application instructions and the use of professional-grade vinyl, you can achieve a smooth, bubble-free finish that looks like it was applied by a pro!
- » **ORDERING INFO** on pages 114-115

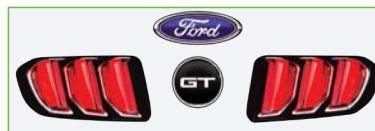

PREMIUM CARBON FIBER FLAT SHEETS

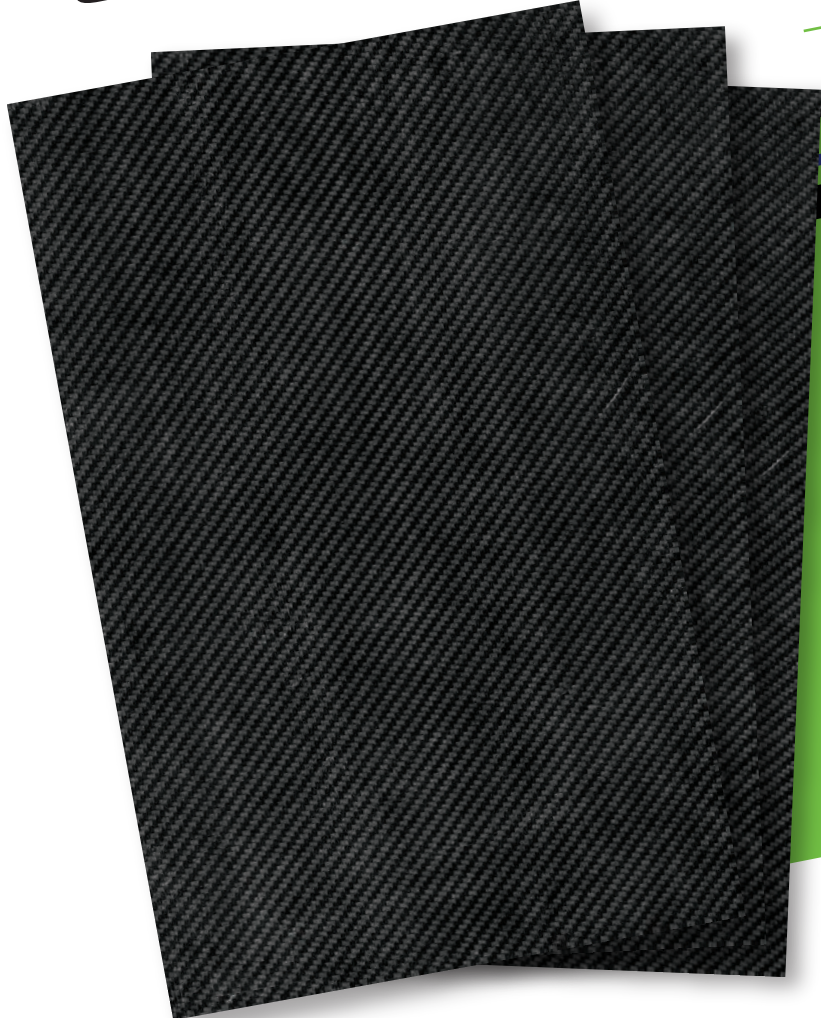

- » True cosmetic carbon fiber surface finish
- » Flat sheets allow you to custom fit your needs
- » Very high strength to weight ratio & heat tolerance
- » Excellent vibration damping characteristics
- » Laminated for additional strength & durability
- » Perfect for Interior accent panels

**2'x4' & 4'x8' FLAT SHEETS
READY TO CUT & FIT!**

STANDARD WEIGHT CARBON FIBER FLAT SHEETS

» Sheets laminated with 2 layers carbon fiber, 1 layer woven fiberglass unless otherwise noted

090-04412	.040" thick, 2'x4'	\$178
090-00412	.040" thick, 4'x8' (1 LAYER CARBON FIBER 2 LAYER WOVEN FIBERGLASS)	\$704
090-00421	.040" thick, 4'x8'	\$761
090-00612	.050" thick, 4'x8'	\$802

LIGHTWEIGHT CARBON FIBER FLAT SHEETS

» Multi-layer laminate consisting of 100% carbon fiber to create the lightest panel possible

090-04430	.040" thick, 2'x4'	\$213
090-00220	.028" thick, 4'x8'	\$695
090-00430	.040" thick, 4'x8'	\$816

ENGINEERED THROUGH THE DRIVER'S EYES



TOP ALCOHOL FUNNY CAR

OFFICIAL GM LICENSED CHEVROLET CAMARO BODY

The perfect blend of speed and style, officially recognized for its authenticity & excellence in the world of drag racing.





» **ALL CARBON FIBER CONSTRUCTED BODY:**

- » Body mounting tabs laminated into the structure for ease of installation
- » Body comes with a gray ready to paint surface finish
- » Fits up to 125" wheelbase chassis
- » Weighs under 90 lbs

CONNECT WITH TEAM FIVE STAR | FIVESTARBODIES.COM    

CAMARO FUNNY CAR BODY & WINDOWS

COMPLETE FUNNY CAR BODY SOLD THROUGH CHEVROLET PERFORMANCE

» BILL SCHEMERS: 810.397.9688 EMAIL: BILL.S@TGIDIRECT.COM

COMPLETE CAMARO FUNNY CAR BODY

Includes Tethered Burst Panel, & Escape Hatch	GM 88958780	*CALL
---	-------------	-------

REPLACEMENT PANELS & WINDOWS

Tethered Burst Panel	GM 88958780-B	\$518
Escape Hatch	GM 88958780-H	\$368
Spill Plate Set (INCLUDES LEFT & RIGHT SPILL PLATES & SPILL PLATE ANGLES)	GM 88958780-S	\$1,297
Parachute Boxes, pair (INCLUDES LEFT & RIGHT)	GM 88958780-P	\$661
Windshield, laminated, mar-resistant coated, .265", cut to fit, beveled, countersunk	68131-63558	\$920
Windshield, mar-resistant coated, 1/4", cut to fit, beveled	68131-63452	\$503
Windshield, mar-resistant coated, 3/16", cut to fit, beveled	68131-63352	\$525
Windows, Door, pair, mar-resistant coated, 1/8", cut to fit, beveled	68131-62252	\$242



UPGRADE TO FIVE STAR'S EXCLUSIVE LAMINATED WINDOW

- » Multi-layer laminated material deflects heavy impact for enhanced driver safety
- » Similar thickness to monolithic (single-layer) polycarbonate windows
- » The BEST OPTICAL QUALITY window available
- » High tech protective coatings applied
- » CNC machined and drilled for exact fit
- » Available exclusively from Five Star
- » Mandated windshield material used for all top NASCAR divisions

VINYL BODY ID GRAPHIC ID KITS FOR A REALISTIC DEM LOOK!

PRINTED ON OUTDOOR DURABLE HIGH-TACK VINYL • GLOSSY LAMINATED SURFACE PROVIDES EXCELLENT PROTECTION



CHEVROLET CAMARO

Body ID Kit	68131-44382	\$79
-------------	-------------	------

KIT INCLUDES: NOSE, TAIL, SWEEPS, WINDOW BLACKOUTS



'15 CHEVROLET CAMARO

Body ID Kit	68131-44381	\$79
-------------	-------------	------

KIT INCLUDES: NOSE, TAIL, SWEEPS, WINDOW BLACKOUTS

PREMIUM CARBON FIBER FLAT SHEETS

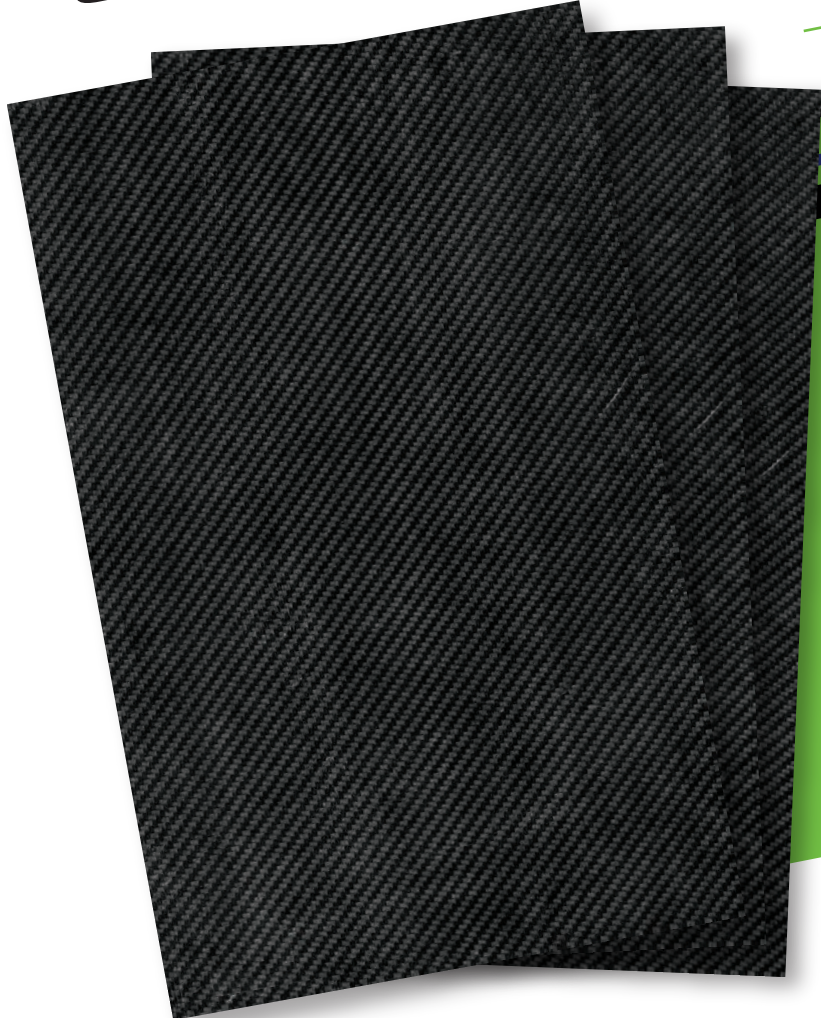

- » True cosmetic carbon fiber surface finish
- » Flat sheets allow you to custom fit your needs
- » Very high strength to weight ratio & heat tolerance
- » Excellent vibration damping characteristics
- » Laminated for additional strength & durability
- » Perfect for Interior accent panels

**2'x4' & 4'x8' FLAT SHEETS
READY TO CUT & FIT!**

STANDARD WEIGHT CARBON FIBER FLAT SHEETS

» Sheets laminated with 2 layers carbon fiber, 1 layer woven fiberglass unless otherwise noted

090-04412	.040" thick, 2'x4'	\$178
090-00412	.040" thick, 4'x8' (1 LAYER CARBON FIBER 2 LAYER WOVEN FIBERGLASS)	\$704
090-00421	.040" thick, 4'x8'	\$761
090-00612	.050" thick, 4'x8'	\$802

LIGHTWEIGHT CARBON FIBER FLAT SHEETS

» Multi-layer laminate consisting of 100% carbon fiber to create the lightest panel possible

090-04430	.040" thick, 2'x4'	\$213
090-00220	.028" thick, 4'x8'	\$695
090-00430	.040" thick, 4'x8'	\$816

CAMARO FUNNY CAR

BODY DIMENSIONS

NO.	MEASUREMENT LOCATION	MEASUREMENT
1.	Ground clearance; from leading edge of body to 12" behind centerline of front spindle	3" min
2.	Ground clearance; from 12" behind centerline of front axle to the rear of the car	2" min
3.	Vertical height; from centerline of spindle to wheel opening	5" min
4.	Front over hang; from leading edge of body to centerline of the front spindle	40" max
5.	Cowl height; in front of injector hat	5" max
6.	Injector opening width	26" max
7.	Body burst panel; in front of injector hat	288 in ² min
8.	Window height	OEM minus no more than 2"
9.	Fire extinguisher window opening; both sides	6" Diameter min
10.	Center of rear axle to trailing edge of rocker panel	18" min
11.	Vertical height from center line of rear axle to wheel opening	8" min
12.	Height; trailing edge of rear bumper to the ground	29" max
13.	Height; bumper vertical surface	3" min
14.	Wheelbase; right/passenger side: max 2" difference between	100" min / 125" max
15.	Wheelbase; left/driver side: max 2" difference between	100" min / 125" max
16.	Rear over hang; centerline of rear axle to trailing edge of rear bumper	54" max
17.	Bumper opening; for parachute shroud lines	30" x 4" max
18.	Roof width	32" min
19.	Roof length; top of front windshield to top of rear window	OEM +/- 4"
20.	Escape hatch length	18" min
21.	Escape hatch width	17" min
22.	Body width; at centerline of front axles - max difference 6"	60" min
23.	Body width; at centerline of rear axles - max difference 6"	60" min
24.	Spoiler width; outside	54" max
25.	Spoiler over hang; centerline of rear axle to trailing edge of spoiler	56" max
26.	Spoiler height; above top of roof; may not be above spill plates	4" max
27.	Spill plate height; above top roof	5" max
28.	Lip around body; fenders, bumpers, rocker panels	1" max
29.	Hinged tail light openings	100 in ² max each side
30.	Spill plate over hang; centerline of rear axle to trailing edge of spill plates	60" max
31.	Rear deck between spill plates; depth below rear deck outside spill plates	1.75" max
32.	Top of spill plate to ground; height	60" max

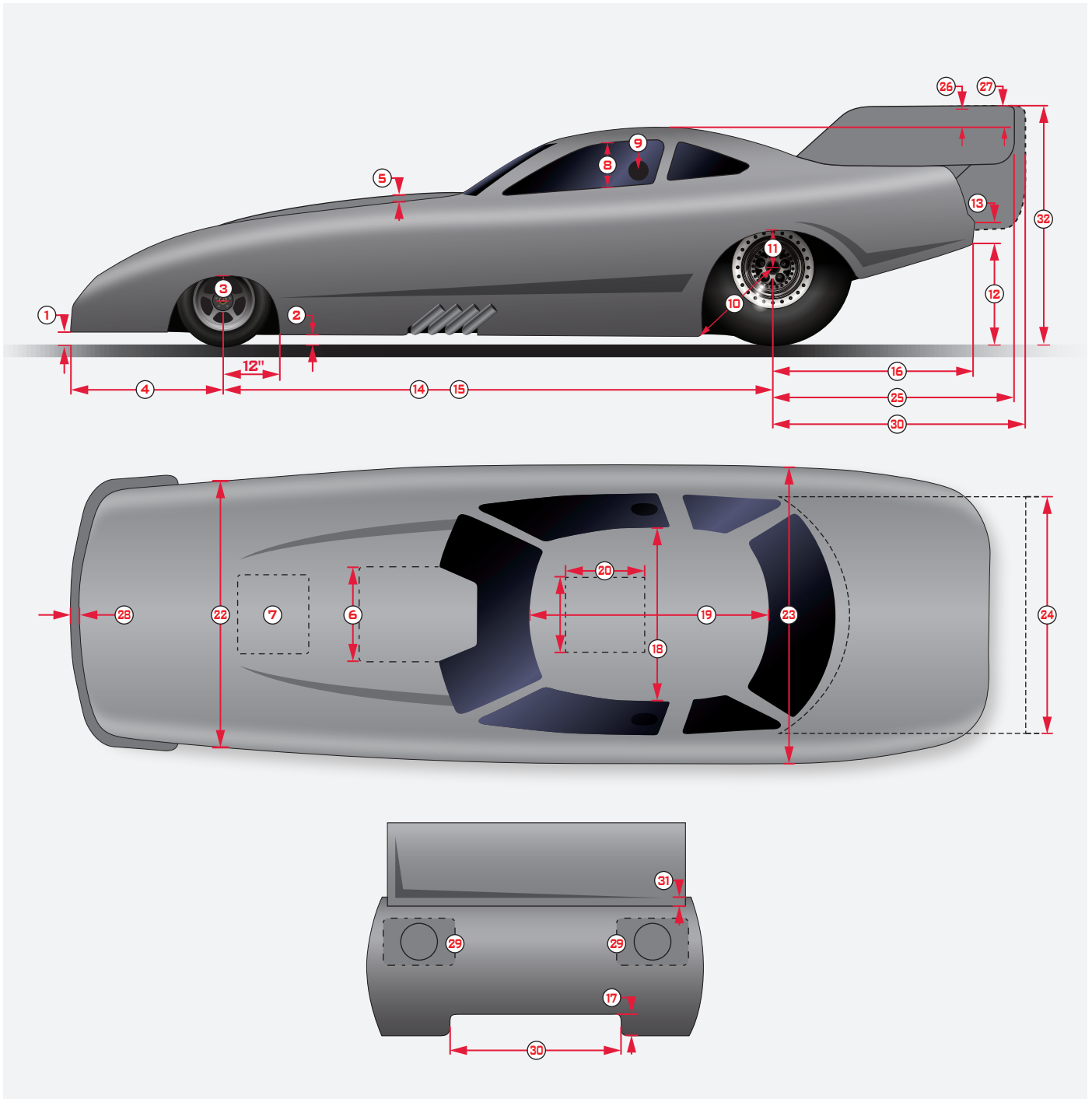

» DOWNLOAD OFFICIAL RULEBOOK @ NHRARACER.COM

HAVE A TECH QUESTION? THE NHRA ALSO HAS RESOURCES FOR ALL NHRA DIVISIONS TO ANSWER YOUR QUESTIONS ABOUT SAFETY, RULES & COMPLIANCE. VISIT NHRARACER.COM



PRICING SUBJECT TO CHANGE WITHOUT NOTICE



THE NEW DODGE CHARGER
JUNIOR DRAGSTER
ADVANCED LIGHTWEIGHT COMPOSITE FOR MAXIMUM SPEED!

COMPLETE DODGE CHARGER JUNIOR DRAGSTER BODY

- » Advanced Lightweight Composite Body
- » Comes in a gray ready to paint surface finish
- » Fits an 85-½" wheelbase chassis
- » Weighs under 30 lbs

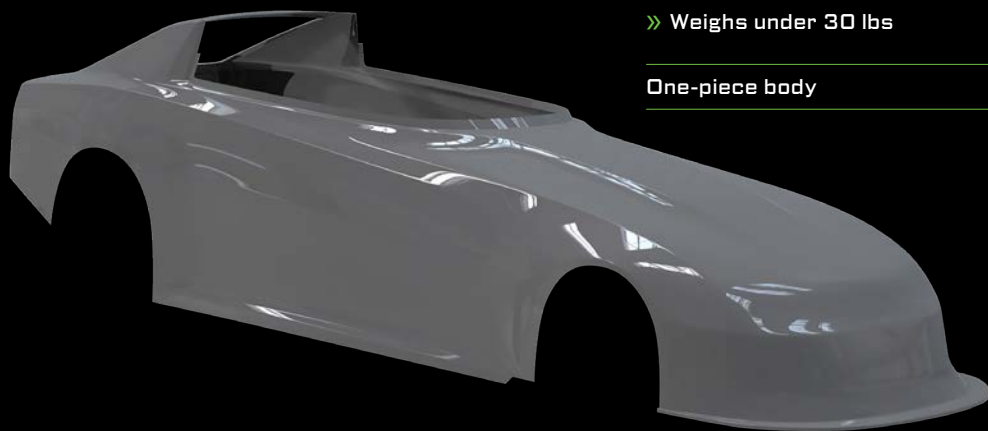

One-piece body	66511-43412	\$3,765
----------------	-------------	---------

DODGE CHARGER JUNIOR DRAGSTER WINDSHIELDS

- » Engineered for superior strength to ensure top-level safety
- » Screen-printed permanent blackout border available
- » Proprietary coating to increase longevity of window
- » Made from our durable polycarbonate material

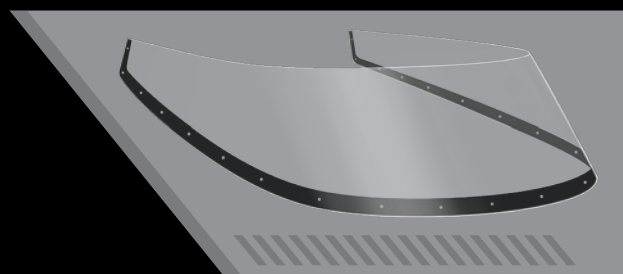

Windshield, 1/8", black-out border	66511-63253	\$492
------------------------------------	-------------	-------

WINDOW INSTALLATION KIT

- » Using proper hardware provides the perfect fit & helps to increase the life of your window
- » Black oxide coated to prevent rust
- » Enough hardware to install a complete set of windows on one car
- » Kit includes: 120 6-32 1/2" & 16 6-32 3/4" flat head socket screws, 136 6-32 nylon locknuts, 1 long-arm hex key & 9/64" drill bit



Window Installation Kit	805	\$27
-------------------------	-----	------

SCAN HERE TO



SHOP ONLINE

ENGINEERED THROUGH THE DRIVER'S EYES



RACING WINDOWS

THE #1 WINDOWS IN MOTORSPORTS

Explore the widest variety of racing windows in the industry. The list of options is endless! If you don't find what you are looking for, see our custom window section and build your own.



» **OPTICAL GRADE MATERIALS:**

Our exclusive grade of polycarbonate material is better than glass, developed exclusively for & only available at Five Star

» **EXCELLENT HARD-COATING:**

Our multiple coating types greatly enhance durability with abrasion & chemical resistance, along with UV & anti-fog protection

» **SCREEN PRINTED BLACK-OUT BORDERS:**

Our borders use a scratch resistant, non-flaking permanent ink for a clean & professional look, saving you hours of work

» **CNC TRIMMED FOR EASY INSTALLATION:**

Our windows are CNC cut to size with smooth, beveled edges & pre-drilled holes for a consistent, perfect fit

PREMIUM RACING WINDOWS

FEATURES & OPTIONS

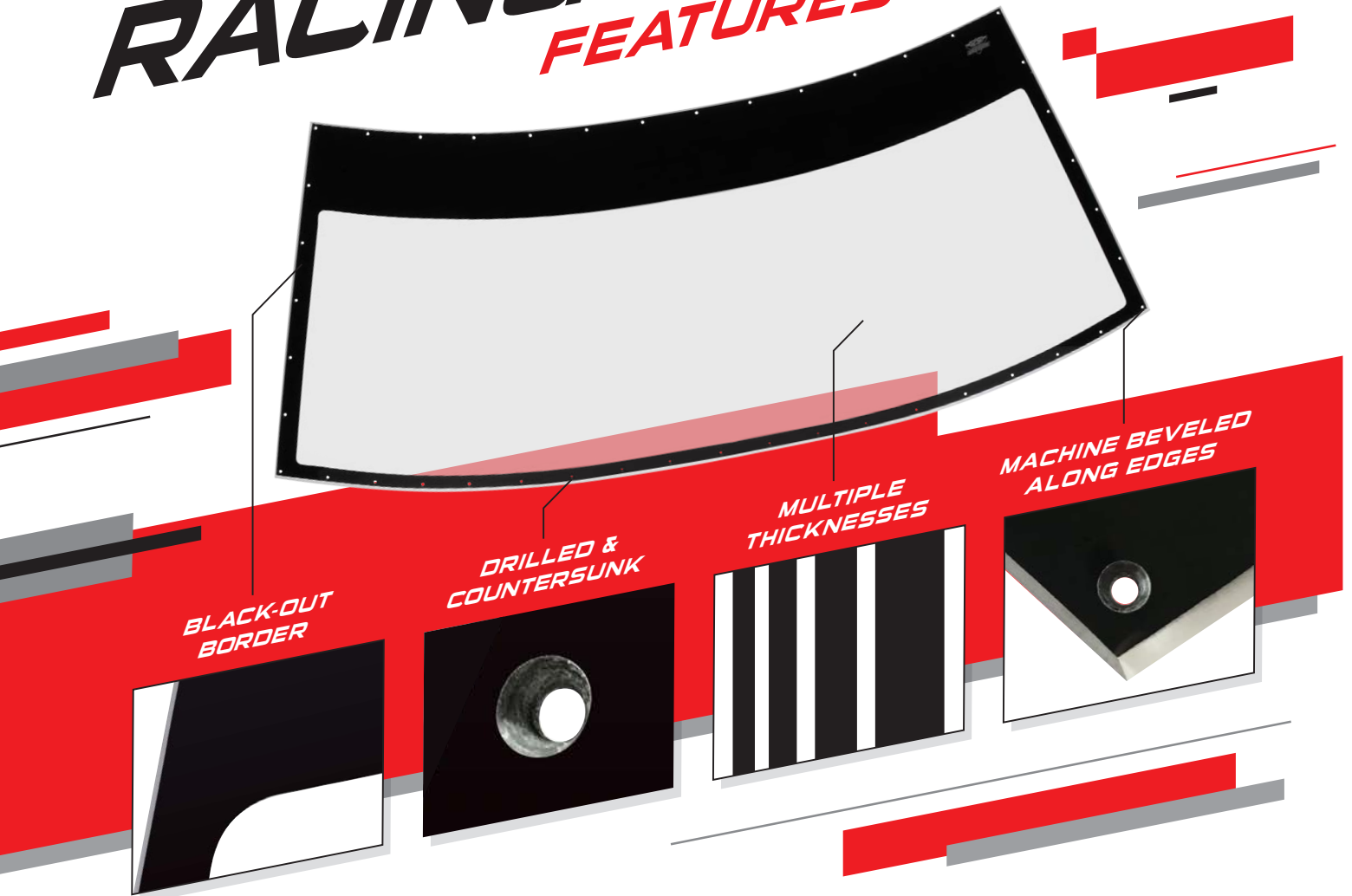

MATERIAL:

- » Two Monolithic Polycarbonate options & thickness:
 - » Clear - 100% Light Transmission
 - » Tinted - 18% Light Transmission
- » Five Star SafeGuard Laminated Polycarbonate Thickness: 0.265"

COATED OR UNCOATED:

- » Mar-Resistant coated or uncoated (economy)
- » Coated windows last longer and save you money over time
- » Uncoated polycarbonate is cheaper but offers no protection against scratching, hazing, and the damaging effects of UV. Plus, cleaning an uncoated window can cause scratch marks that affect visibility.

EDGE TREATMENT:

- » Edges can be machine beveled and will fit exactly into the window frame

CUT:

- » Oversize: Typically cut 1-1/2 inches larger than the window frame; requires cutting, trimming, beveling and drilling
- » Precut to Fit: Straight-cut to fit exactly into the window frame

INSTALLATION OPTIONS:

- » Option 1: Installation holes are pre-drilled.
- » Option 2: Installation holes are pre-drilled & countersunk

BLACK-OUT BORDER:

- » Professional appearance is printed with ultra-durable, high-quality, scratch-resistant and non-flaking permanent ink.
- » Black-out borders are available on custom formed windows for higher-quantity production runs ONLY.

BUILD YOUR OWN CUSTOM WINDOWS

» CALL OUR SALES TEAM AT 262.877.2171 FOR YOUR CUSTOM WINDOW NEEDS!

CUSTOM WINDOW SPECIFICATIONS

THESE TWO DIMENSIONS ARE NEEDED TO DETERMINE WHICH SHEET TO PURCHASE:

DIM A - THE HEIGHT: Place your window on end upon a level space with the roof edge down. Measure (DIM A), from the floor to the highest point

DIM B - THE WIDTH: Measure across the widest point (DIM B) to be sure that the width does not exceed 70"

» If DIM A is less than 39" use Sheet #1

» If DIM A is 39-47" use Sheet #2

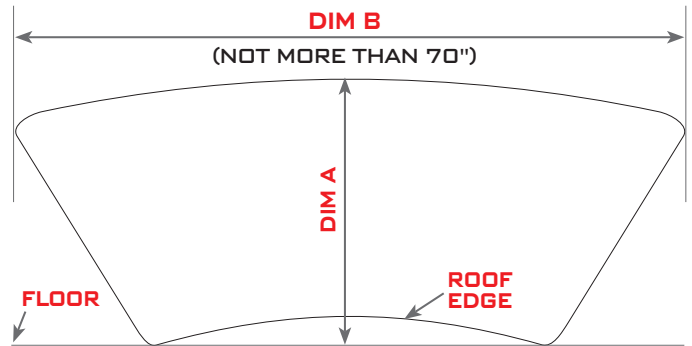

MATERIAL	THICKNESS	SHEET #1	SHEET #2
Clear	.093"	\$317	\$363
Tint	.093"	N/A	\$436
Clear	.118" (1/8")	\$353	\$399
Tint	.118" (1/8")	N/A	\$479
Clear	.177" (3/16")	\$424	\$462
Clear	.236" (1/4")	\$505	\$616

IMPORTANT INFORMATION:

- » Oversized molded sheets are typically 1-1/2" larger than stock (you cut it to fit)
- » Sheets are formed, not flat. Prices on this chart include all forming costs.
- » Contact our Five Star Sales Team for complete ordering information, or to determine whether or not factory glass window is needed for tooling purposes

POLYCARBONATE FLAT SHEETS

MAR-RESISTANT FLAT SHEETS CANNOT BE THERMOFORMED! Tint is dark gray with 18% light transmission. Custom sheet sizes are available upon request, and with a minimum order quantity.

PART #	CLEAR/TINT	THICKNESS	SHEET SIZE	COATING	PRICE
000-6102	Clear	.093"	40" x 72"	uncoated	\$93
000-6112	Tint	.093"	40" x 72"	mar-resistant	\$223
000-6300	Clear	.118" (1/8")	24" x 48"	mar-resistant	\$68
000-6301	Clear	.118" (1/8")	32" x 72"	mar-resistant	\$136
000-6303	Clear	.118" (1/8")	36" x 72"	mar-resistant	\$174
000-6302	Clear	.118" (1/8")	40" x 72"	mar-resistant	\$189
000-6122	Tint	.118" (1/8")	40" x 72"	mar-resistant	\$247
000-6306	Clear	.118" (1/8")	72" x 96"	mar-resistant	\$408
000-6304	Clear	.177" (3/16")	36" x 72"	mar-resistant	\$233

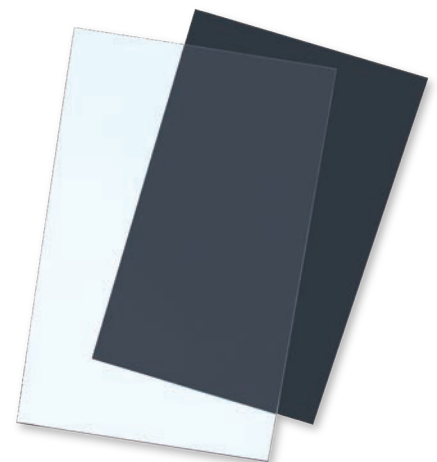

POLYCARBONATE FLAT SHEETS

» GO TO FIVESTARBODIES.COM TO SEE OUR FULL LINE OF WINDOWS!

PRICING SUBJECT TO CHANGE WITHOUT NOTICE

FACTORY STOCK DIMENSION WINDOWS

THICKNESS
OVERSIZE
PRECUT TO FIT
BEVELED
DRILLED
COUNTERSUNK
BLACK OUT
SPECIAL ORDER

CHEVROLET CAMARO FIFTH GEN: 2010-2015

Windshield	164-6345-1	1/4"	X							\$507
Windshield	164-6345-2	1/4"		X						\$539
Windshield	164-6335-2	3/16"		X						\$453
Window, Door, left or right	164-6235-2LorR	3/16"		X						\$256
Window, Door, left or right	164-6225-2LorR	1/8"		X						\$215
Window, Quarter, left or right	164-6535-2LorR	3/16"		X						\$97
Window, Quarter, left or right	164-6525-2LorR	1/8"		X						\$85
Window, Rear	164-6135-2	3/16"		X						\$439
Window, Rear	164-6125-1	1/8"	X							\$354
Window, Rear	164-6125-2	1/8"		X						\$383

CHEVROLET CAMARO FOURTH GEN: 1993-2002

Windshield	150-6345-STK	1/4"	X							\$484
Windshield	150-6335-STK	3/16"	X							\$427
Windshield	150-6335-2	3/16"		X						\$442
Windshield	150-6325-STK	1/8"	X							\$399
Window, Rear	150-6135-STK	3/16"	X							\$427
Window, Rear	150-6125-STK	1/8"	X							\$399
Window, Rear, uncoated	150-6111	.093"	X							\$200
Window, Rear	150-6115	.093"	X							\$362

CHEVROLET CAMARO THIRD GEN: 1982-1992

Windshield	524-6325	1/8"	X							\$354
Window, Rear	110-6135	3/16"	X							\$427
Window, Rear	110-6125	1/8"	X							\$399
Window, Rear, uncoated	110-6111	.093"	X							\$200
Window, Rear	110-6115	.093"	X							\$362

CHEVROLET CAMARO FIRST GEN: 1967-1969 (CLEAR)

Windshield	114-6335-STK	3/16"	X							\$467
Windshield	114-6325-STK	1/8"	X							\$202
Window, Doors, left or right	114-6225-STK-LorR	1/8"	X							\$98
Window, Doors, left or right	114-6215-STK-LorR	.093"	X							*CALL
Window, Quarters, left or right	114-6525-STK-LorR	1/8"	X							\$66
Window, Quarters, left or right	114-6515-STK-LorR	.093"	X							*CALL
Window, Rear	114-6125-STK	1/8"	X							\$202

CHEVROLET CAMARO FIRST GEN: 1967-1969 (TINTED)

Window, Doors, left or right	114-6225-TINT-LorR	1/8"	X						X	\$118
Window, Doors, left or right	114-6215-TINT-LorR	.093"	X						X	\$111
Window, Quarters, left or right	114-6525-TINT-LorR	1/8"	X						X	\$80
Window, Quarters, left or right	114-6515-TINT-LorR	.093"	X						X	\$42
Window, Rear	114-6125-TINT	1/8"	X						X	\$243
Window, Rear	114-6115-TINT	.093"	X						X	\$222

FACTORY STOCK DIMENSION WINDOWS

THICKNESS OVERSIZE PRECUT TO FIT BEVELED DRILLED COUNTERSUNK BLACK OUT SPECIAL ORDER

CHEVROLET CORVETTE C7: 2014-2019

Windshield	80145-63402	1/4"	X							\$484
Windshield	80145-63422	1/4"		X						\$501
Windshield	80145-63302	3/16"	X							\$427
Windshield	80145-63322	3/16"		X						\$442
Windshield	80145-63222	1/8"		X						\$415
Window, Quarter, left or right	80145-65222LorR	1/8"		X						\$32
Window, Rear	80145-61302	3/16"	X							\$317
Window, Rear	80145-61322	3/16"		X						\$347
Window, Rear	80145-61202	1/8"	X							\$282
Window, Rear	80145-61222	1/8"		X						\$310

CHEVROLET CORVETTE: C7 CYNERGY BODY

Windshield	65145-63302	3/16"	X							\$404
Windshield	65145-63202	1/8"	X							\$340
Windshield	65145-63102	.093"	X							\$340
Window, Rear	65145-61202	1/8"	X							\$340
Window, Rear	65145-61102	.093"	X							\$340
Window, Rear (TINTED)	65145-61204	1/8"	X					X		\$396

CHEVROLET CORVETTE C6: 2005-2013

Headlight Covers	923-410HC	.093"	X							\$90
Windshield	923-6345-1	1/4"	X							\$484
Windshield	923-6345-2	1/4"		X						\$501
Windshield	923-6345-2B	1/4"		X			X			\$535
Windshield	923-6335-1	3/16"	X							\$427
Windshield	923-6335-2	3/16"		X						\$442
Window, Rear	923-6135-2B	3/16"		X			X			\$512
Window, Rear	923-6125-2	1/8"		X						\$415
Window, Rear	923-6125-2B	1/8"		X			X			\$479
Window, Rear	923-6125-1	1/8"	X							\$399

CHEVROLET CORVETTE C5: 1997-2004

Windshield	922-6345-1	1/4"	X							\$484
Windshield	922-6345-2	1/4"		X						\$501
Windshield	922-6335-1	3/16"	X							\$427
Windshield	922-6335-2	3/16"		X						\$442
Windshield	922-6325-1	1/8"	X							\$399
Windshield	922-6325-2	1/8"		X						\$415
Window, Rear	922-6135-1	3/16"	X							\$427
Window, Rear (Z06 style)	922-6135-1 Z06	3/16"	X							\$317
Window, Rear	922-6135-2	3/16"		X						\$477
Window, Rear	922-6125-1	1/8"	X							\$399
Window, Rear	922-6125-2	1/8"		X						\$415

FACTORY STOCK DIMENSION WINDOWS

THICKNESS
OVERSIZE
PRECUT TO FIT
BEVELED
DRILLED
COUNTERSUNK
BLACK OUT
SPECIAL ORDER

CHEVROLET CORVETTE C4: 1984-1996

Windshield	920-6345-1	1/4"	X							\$507
Windshield	920-6345-2	1/4"		X						\$524
Windshield	920-6335-1	3/16"	X							\$423
Windshield	920-6335-2	3/16"		X						\$439
Windshield	920-6325-1	1/8"	X							\$354
Windshield	920-6325-2	1/8"		X						\$369
Window, Rear	920-6135-1	3/16"	X							\$423
Window, Rear	920-6135-2	3/16"		X						\$439
Window, Rear	920-6125-1	1/8"	X							\$354
Window, Rear	920-6125-2	1/8"		X						\$369

CHEVROLET CORVETTE C2: 1963-1967

Window, Rear	920-6125-SPLIT	1/8"	X							\$227
--------------	----------------	------	---	--	--	--	--	--	--	-------

*TRIMMABLE TO SPLIT WINDOW, NOTCHED TO HELP CUT SPLIT

CHEVROLET MONTE CARLO: 1981-1988

Windshield	524-6325	1/8"	X							\$354
Windshield, flat	600-6303	1/8"		X						\$233
Window, Rear (Aero Coupe)	604-6125-A	1/8"	X							\$371
Window, Rear, flat, uncoated	600-6101	.093"		X						\$61

DODGE VIPER GTS: 1996-1999

Windshield	906-6345-1	1/4"	X							\$507
Windshield	906-6335-1	3/16"	X							\$423
Window, Rear	906-6125	1/8"	X							\$354

FORD MUSTANG FIFTH GEN: 2005-2014

Windshield	902-6345-STK	1/4"	X							\$507
Windshield	902-6335-STK	3/16"	X							\$384
Windshield	902-6325-STK	1/8"	X							\$322
Window, Rear	902-6135-STK	3/16"	X							\$423
Window, Rear	902-6125-STK	1/8"	X							\$354

FORD MUSTANG FOURTH GEN: 1994-2004

Windshield	900-6345-1	1/4"	X							\$507
Windshield	900-6335-1	3/16"	X							\$423
Windshield	900-6325-1	1/8"	X							\$354
Window, Rear	900-6135	3/16"	X							\$423
Window, Rear	900-6125	1/8"	X							\$354



FACTORY STOCK DIMENSION WINDOWS

THICKNESS
OVERSIZE
PRECUT TO FIT
BEVELED
DRILLED
COUNTERSUNK
BLACK OUT
SPECIAL ORDER

PONTIAC FIREBIRD FOURTH GEN: 1993-2002

Windshield	150-6345-STK	1/4"	X							\$484
Windshield	150-6335-STK	3/16"	X							\$427
Windshield	150-6335-2	3/16"		X						\$442
Windshield	150-6325-STK	1/8"	X							\$399
Window, Rear	150-6135-STK	3/16"	X							\$427
Window, Rear	150-6125-STK	1/8"	X							\$399

PONTIAC FIREBIRD THIRD GEN: 1982-1992

Window, Rear	110-6135	3/16"	X							\$427
Window, Rear	110-6125	1/8"	X							\$399

PONTIAC GRAND PRIX: 1996-2003

Windshield	324-6345-1	1/4"	X							\$507
Windshield	324-6335-1	3/16"	X							\$393
Windshield	324-6325	1/8"	X							\$354
Window, Rear	324-6125	1/8"	X							\$354

BMW E30 COUPE: 1985-1991

Windshield	953-6345-2	1/4"		X						\$524
Window, Quarter, pair	953-6525	1/8"	X							\$215
Window, Rear	953-6135-2	3/16"		X						\$388
Window, Rear, M3 model	953-6135-2M	3/16"		X						\$388

BMW E36 COUPE: 1992-1998

Windshield	951-6345-2	1/4"		X						\$524
Window, Quarter, left or right	951-6525-2LorR	1/8"		X						\$147
Window, Rear	951-6135-2	3/16"		X						\$453

BMW E36 SEDAN: 1992-1998

Windshield	951-6345-4	1/4"		X						\$524
Window, Rear	951-6135-4	3/16"		X						\$453

BMW E46 COUPE: 2000-2006

Windshield	952-6345-2	1/4"		X						\$524
Windshield	952-6335-2	3/16"		X						\$383
Window, Quarter, left or right	952-6525-2LorR	1/8"		X						\$147
Window, Rear	952-6135-2	3/16"		X						\$453
Window, Rear	952-6125-2	1/8"		X						\$311

MAZDA MIATA MX-5: 2006-2015

Windshield	80771-63422	1/4"		X				X		\$524
------------	-------------	------	--	---	--	--	--	---	--	-------

PORSCHE 911 SERIES 991: 2011-2019

Windshield	991-6345-2	1/4"		X						\$524
------------	------------	------	--	---	--	--	--	--	--	-------

FACTORY STOCK DIMENSION WINDOWS

THICKNESS
OVERSIZE
PRECUT TO FIT
BEVELED
DRILLED
COUNTERSUNK
BLACK OUT
SPECIAL ORDER

PORSCHE 911 SERIES 997: 2005-2013

Windshield	997-6345-2	1/4"		X						\$524
Windshield	997-6335-2	3/16"		X						\$439
Window, Quarter, pair	996/7-6525-2	1/8"		X						\$192
Window, Rear	997-6125-2	1/8"		X						\$415

PORSCHE 911 SERIES 996: 1997-2006

Windshield	996-6345-2	1/4"		X						\$524
Windshield	996-6335-2	3/16"		X						\$439
Window, Quarter, pair	996/7-6525-2	1/8"		X						\$192
Window, Rear	996-6125-2	1/8"		X						\$415

PORSCHE 911 SERIES 993: 1995-1998

Windshield, C2/C4 models	911-6345-2C	1/4"		X						\$524
--------------------------	-------------	------	--	---	--	--	--	--	--	-------

PORSCHE 911: 1964-1994

Windshield	911-6345-1	1/4"	X							\$507
Windshield	911-6345-2	1/4"		X						\$524
Windshield, C2/C4 models	911-6345-2C	1/4"		X						\$524
Windshield	911-6335-1	3/16"	X							\$423
Windshield	911-6335-2	3/16"		X						\$439
Windshield, C2/C4 models	911-6335-2C	3/16"		X						\$439
Window, Rear	911-6135-1	3/16"	X							\$333
Window, Rear	911-6135-2	3/16"		X						\$349
Window, Rear	911-6135F	3/16"		X						\$349
Window, Rear	911-6125-1	1/8"	X							\$282
Window, Rear	911-6125-2	1/8"		X						\$298
Window, Rear	911-6125F	1/8"		X						\$298

PORSCHE 914: 1969-1976

Windshield	943-6345-2	1/4"		X						\$524
------------	------------	------	--	---	--	--	--	--	--	-------

PORSCHE 944: 1982-1991

Windshield	944-6345-1	1/4"	X							\$507
Windshield	944-6345-2	1/4"		X						\$524
Window, Rear	944-6135-1	3/16"	X							\$461
Window, Rear	944-6135-2	3/16"		X						\$477
Window, Rear	944-6125-1	1/8"	X							\$399
Window, Rear	944-6125-2	1/8"		X						\$415

PORSCHE BOXSTER, GEN 1 SERIES 986: 1996-2004

Windshield	994-6345-2	1/4"		X						\$524
Windshield	994-6335-2B	3/16"		X				X		\$443

PORSCHE CAYMAN, GEN 2 SERIES 981/982: 2014 & NEWER

Window, Rear	911-6135-4	3/16"	X							\$453
--------------	------------	-------	---	--	--	--	--	--	--	-------

FACTORY STOCK DIMENSION WINDOWS

THICKNESS OVERSIZE PRECUT TO FIT **OPTIONS** BEVELED DRILLED COUNTERSUNK BLACK OUT SPECIAL ORDER

PORSCHE CAYMAN, GEN 1 SERIES 987: 2006-2013

Window, Rear	911-6135-3	3/16"		X							\$349
--------------	------------	-------	--	---	--	--	--	--	--	--	-------

TOYOTA SUPRA: 1993-1998

Windshield	916-6345-1	1/4"	X								\$444
Windshield	916-6345-2	1/4"		X							\$469
Window, Rear	916-6125-2	1/8"		X							\$341

WINDOW INSTALLATION KIT

- » Using proper hardware provides the perfect fit & helps to increase the life of your window
- » Black oxide coated to prevent rust
- » Enough hardware to install a complete set of windows on one car
- » **Kit includes:** 120 6-32 1/2" & 16 6-32 3/4" flat head socket screws, 136 6-32 nylon locknuts, 1 long-arm hex key & 9/64" drill bit

Window Installation Kit	805	\$27
-------------------------	-----	------



IMPORTANT:

USING RIVETS APPLIES TOO MUCH PRESSURE TO YOUR WINDOW & WILL FRACTURE THE POLYCARBONATE

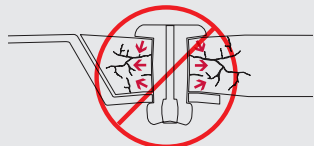

WINDOW INSTALLATION COUNTERSINK DRILL BIT

- » 3/8" diameter steel bit with a 1/4" shank, used for countersinking holes for window screw installation into polycarbonate
- » Not required for precut to fit, beveled, & drilled windows

Drill Bit	805-1	\$19
-----------	-------	------



FIVE STAR PLASTIC WINDOW CLEANER

- » This specially formulated anti-static foaming spray contains no chemicals or abrasives that will cause damage to plastic
- » Lifts grease, grime, and wipes off fast and easy to provide a streak-free clean and clear surface finish

Window Cleaner, 19oz Can	843	\$9.95
--------------------------	-----	--------



» FIVE STAR CLEANING TIPS!

- » ALWAYS AVOID USING ABRASIVE CLEANERS & CHEMICAL SOLVENTS THAT CAN EASILY CAUSE DAMAGE TO POLYCARBONATE WINDOWS
- » USE A MICROFIBER TOWEL FOR BEST, STREAK-FREE FINISH
- » TO PREVENT SCRATCHING AND HAZING ON YOUR WINDOWS, NEVER SCRUB WITH BRUSHES OR ABRASIVE MATERIALS

WINDOWS FOR AFTERMARKET DRAG RACING BODIES

THICKNESS
OVERSIZE
PRECUT TO FIT
BEVELED
DRILLED
COUNTERSUNK
BLACK OUT
SPECIAL ORDER

PRO STOCK / PRO MOD CHEVROLET CAMARO: 2017 & NEWER (CLEAR)

		THICKNESS	OVERSIZE	PRECUT TO FIT	BEVELED	DRILLED	COUNTERSUNK	BLACK OUT	SPECIAL ORDER	
Windshield	64131-63302	3/16"	X							\$397
Windshield	64131-63332	3/16"		X	X					\$472
Windshield	64131-63202	1/8"	X							\$382
Windshield	64131-63232	1/8"		X						\$409
Window, Door, left or right	64131-62202LorR	1/8"	X							\$158
Window, Door, left or right	64131-62232LorR	1/8"		X	X					\$191
Window, Door, left or right	64131-62102LorR	.093"	X							\$126
Window, Door, left or right	64131-62132LorR	.093"		X	X					\$145
Window, Quarter, left or right	64131-65242LorR	1/8"		X	X	X				\$42
Window, Quarter, left or right	64131-65142LorR	.093"		X	X	X				\$40
Window, Rear	64131-61242	1/8"		X	X	X				\$398
Window, Rear	64131-61142	.093"		X	X	X				\$264

PRO STOCK / PRO MOD CHEVROLET CAMARO: 2017 & NEWER (TINTED)

Window, Door, left or right	64131-62204LorR	1/8"	X						X	\$173
Window, Door, left or right	64131-62234LorR	1/8"		X	X				X	\$212
Window, Quarter, left or right	64131-65244LorR	1/8"		X	X	X			X	\$51
Window, Rear	64131-61244	1/8"		X	X	X			X	\$411

DRAG PRO STOCK / PRO MOD CHEVROLET CAMARO: 2012-2016

Windshield	961-6335-1	3/16"	X							\$344
Windshield	961-6335-2	3/16"		X	X					\$369
Windshield	961-6325-2	1/8"		X						\$340
Window, Door, left or right	960-6225-2LorR	1/8"		X	X					\$160
Window, Door, left or right	960-6215-2LorR	.093"		X	X					\$121
Window, Quarter, left or right	960-6525-2LorR	1/8"		X	X	X				\$110
Window, Quarter, left or right	960-6515-2LorR	.093"		X	X	X				\$80
Window, Rear	960-6125-2	1/8"		X	X	X				\$311
Window, Rear	960-6115-2	.093"		X	X	X				\$220

DRAG PRO MOD CHEVROLET CAMARO: 2011

Windshield	960-6335-2	3/16"		X	X					\$369
Windshield	960-6325-1	1/8"	X	X	X					\$379
Window, Door, left or right	960-6225-1LorR	1/8"	X	X	X					\$157
Window, Door, left or right	960-6225-2LorR	1/8"		X	X					\$160
Window, Door, left or right	960-6215-2LorR	.093"		X	X					\$121
Window, Quarter, left or right	960-6525-2LorR	1/8"		X	X	X				\$110
Window, Quarter, left or right	960-6515-2LorR	.093"		X	X	X				\$80
Window, Rear	960-6125-1	1/8"	X		X	X				\$286
Window, Rear	960-6125-2	1/8"		X	X	X				\$311
Window, Rear	960-6115-2	.093"		X	X	X				\$220

WINDOWS FOR AFTERMARKET DRAG RACING BODIES

OPTIONS

THICKNESS	OVERSIZE	PRECUT TO FIT	BEVELED	DRILLED	COUNTERSUNK	BLACK OUT	SPECIAL ORDER
-----------	----------	------------------	---------	---------	-------------	-----------	------------------

PRO MOD CHEVROLET CAMARO: 1967-1969 (CLEAR)

Windshield	114-6335-DRAG	3/16"	X							\$379
Windshield	114-6325-DRAG	1/8"	X							\$202
Window, Door, left or right	114-6225-DRAG-LorR	1/8"	X							\$98
Window, Quarter, left or right	114-6525-DRAG-LorR	1/8"	X							\$66
Window, Door, left or right	114-6215-DRAG-LorR	.093"	X							\$60
Window, Quarter, left or right	114-6515-DRAG-LorR	.093"	X							\$35
Window, Rear	114-6125-DRAG	1/8"	X							\$202
Window, Rear	114-6115-DRAG	.093"	X							\$185

PRO MOD CHEVROLET CAMARO: 1967-1969 (TINTED)

Window, Doors, left or right	114-6225-TINT-LorR	1/8"	X						X	\$118
Window, Doors, left or right	114-6215-TINT-LorR	.093"	X						X	\$111
Window, Quarters, left or right	114-6525-TINT-LorR	1/8"	X						X	\$80
Window, Quarters, left or right	114-6515-TINT-LorR	.093"	X						X	\$42
Window, Rear	114-6125-TINT	1/8"	X						X	\$243
Window, Rear	114-6115-TINT	.093"	X						X	\$222

CHEVROLET COBALT

Windshield	913-6335-1	3/16"	X							\$344
Windshield	913-6335-2	3/16"		X	X					\$369
Windshield	913-6325-1	1/8"	X							\$287
Window, Door, left or right	913-6225LorR	1/8"	X							\$131
Window, Door, left or right	913-6225-2LorR	1/8"		X	X					\$143
Window, Quarter, left or right	913-6525LorR	1/8"	X							\$98
Window, Quarter, left or right	913-6525-2LorR	1/8"		X	X	X				\$110
Window, Rear	913-6125	1/8"	X							\$286
Window, Rear	913-6125-2	1/8"		X	X	X				\$311

CHEVROLET CAVALIER

Windshield	904-6335-1	3/16"	X							\$344
Windshield	904-6325-1	1/8"	X							\$353
Window, Door, left or right	904-6225LorR	1/8"	X							\$144
Window, Quarter, fits either side	903-6525	1/8"	X							\$85
Window, Rear	904-6125	1/8"	X							\$286

CHEVROLET CAVALIER (TINTED)

Window, Door, left or right	904-6225LorR-TNT	1/8"	X						X	\$341
Window, Quarter, fits either side	903-6525-TNT	1/8"	X						X	\$107
Window, Rear	904-6125-TNT	1/8"	X						X	\$365

DODGE AVENGER

Windshield	909-6335-2	3/16"		X	X	X				\$369
Windshield, trim at base	909-6335-1	3/16"	X							\$344
Windshield	909-6325-1	1/8"	X							\$287
Window, Door, left or right	909-6225-2LorR	1/8"		X	X	X				\$94
Window, Quarter, left or right	909-6525-2LorR	1/8"		X	X	X				\$85
Window, Rear	909-6125-2	1/8"		X	X	X				\$272

WINDOWS FOR AFTERMARKET DRAG RACING BODIES

THICKNESS
OVERSIZE
PRECUT TO FIT
BEVELED
DRILLED
COUNTERSUNK
BLACK OUT
SPECIAL ORDER

DODGE DART

Windshield	910-6335-2	3/16"		X	X					\$444
Windshield	910-6325-2	1/8"		X	X					\$382
Window, Door, left or right	910-6225-2LorR	1/8"		X	X					\$191
Window, Door, left or right	910-6215-2LorR	.093"		X	X					\$145
Window, Quarter, left or right	910-6525-2LorR	1/8"		X	X	X				\$117
Window, Quarter, left or right	910-6515-2LorR	.093"		X	X	X				\$92
Window, Rear	910-6135-2	3/16"		X	X	X				\$405
Window, Rear	910-6125-2	1/8"		X	X	X				\$373
Window, Rear	910-6115-2	.093"		X	X	X				\$290

DODGE NEON

Windshield	907-6335-1	3/16"	X							\$344
Windshield	907-6325-1	1/8"	X							\$303
Windows, Door/Quarter, left or right	907-6225LorR	1/8"	X							\$144
Windows, Door/Quarter, left or right	907-6225LorR	1/8"	X							\$144
Window, Rear	907-6125	1/8"	X							\$286
Window, Rear	907-6125-2	1/8"		X						\$340

DODGE STRATUS

Windshield	908-6335-1	3/16"	X							\$344
Windshield	908-6325-1	1/8"	X							\$344
Window, Door, left or right	908-6225LorR	1/8"	X							\$144
Window, Quarter, left or right	908-6525LorR	1/8"	X							\$98
Window, Rear	908-6135	3/16"	X							\$344
Window, Rear	908-6125	1/8"	X							\$286

PRO STOCK / PRO MOD FORD MUSTANG: 2016 & NEWER (CLEAR)

Windshield	64321-63302	3/16"	X							\$379
Windshield	64321-63332	3/16"		X	X					\$406
Windshield	64321-63202	1/8"	X		X					\$353
Windshield	64321-63232	1/8"		X	X					\$383
Window, Door, left or right	64321-62202LorR	1/8"	X							\$144
Window, Door, left or right	64321-62232LorR	1/8"		X	X					\$176
Window, Door, left or right	64321-62102LorR	.093"	X		X					\$121
Window, Door, left or right	64321-62132LorR	.093"	X	X	X					\$145
Window, Quarter, left or right	64321-65242LorR	1/8"		X	X	X				\$121
Window, Quarter, left or right	64321-65142LorR	.093"		X	X	X				\$88
Window, Rear	64321-61242	1/8"		X	X	X				\$398
Window, Rear	64321-61142	.093"		X	X	X				\$242

PRO STOCK / PRO MOD FORD MUSTANG: 2016 & NEWER (TINTED)

Window, Door, left or right	64321-62204LorR	1/8"	X						X	\$173
Window, Door, left or right	64321-62234LorR	1/8"		X	X				X	\$212
Window, Quarter, left or right	64321-65244LorR	1/8"		X	X	X			X	\$146
Window, Rear	64321-61244	1/8"		X	X	X			X	\$411

WINDOWS FOR AFTERMARKET DRAG RACING BODIES

THICKNESS
OVERSIZE
PRECUT TO FIT
BEVELED
DRILLED
COUNTERSUNK
BLACK OUT
SPECIAL ORDER

FORD MUSTANG: 2010 ROUSH BODY

Windshield	901-6335-2	3/16"		X	X						\$369
Windshield	901-6335-1	3/16"	X								\$344
Window, Door, left or right	901-6225-2LorR	1/8"		X	X						\$143
Window, Quarter, left or right	901-6525-2LorR	1/8"		X	X						\$72
Window, Rear	901-6125-2	1/8"		X	X	X					\$311
Window, Rear	901-6125-1	1/8"	X								\$315

FORD MUSTANG: 2005-2009 HAIRY GLASS BODY

Windshield	902-6335-1	3/16"	X								\$313
Windshield	902-6335-2	3/16"		X	X	X	X				\$338
Windshield	902-6325-1	1/8"	X								\$287
Window, Door, left or right	902-6225-2LorR	1/8"		X	X	X	X				\$143
Window, Quarter, left or right	902-6525-2LorR	1/8"		X	X	X	X				\$72
Window, Rear	902-6125-1	1/8"	X								\$261
Window, Rear	902-6125-2	1/8"		X							\$289
Window, Rear	902-6115-1	.093"	X								\$295

PONTIAC GRAND AM (CLEAR)

Windshield	904-6335-1	3/16"	X								\$344
Windshield	904-6325-1	1/8"	X								\$353
Window, Door, left or right	904-6225LorR	1/8"	X								\$144
Window, Quarter, left or right	904-6525LorR	1/8"	X								\$85
Window, Rear	904-6125	1/8"	X								\$286

PONTIAC GRAND AM (TINTED)

Window, Door, left or right	904-6225LorR-TNT	1/8"	X						X		\$341
Window, Quarter, left or right	904-6525LorR-TNT	1/8"	X						X		\$199
Window, Rear	904-6125-TNT	1/8"	X						X		\$365

PONTIAC GTO (CLEAR)

Windshield	914-6335-1	3/16"	X								\$344
Windshield	914-6335-2	3/16"		X	X						\$369
Windshield	914-6325-1	1/8"	X								\$322
Window, Door, left or right	914-6225LorR	1/8"	X								\$131
Window, Door, left or right	914-6225-2LorR	1/8"		X	X						\$143
Window, Quarter, left or right	914-6525LorR	1/8"	X								\$98
Window, Quarter, left or right	914-6525-2LorR	1/8"		X	X	X					\$110
Window, Rear	914-6125	1/8"	X								\$286
Window, Rear	914-6125-2	1/8"		X	X	X					\$311
Window, Rear	914-6115	.093"	X								\$289

PONTIAC GTO (TINTED)

Window, Door, left or right	914-6225-2LorR-TNT	1/8"		X	X				X		\$156
Window, Quarter, left or right	914-6525-2LorR-TNT	1/8"		X	X	X			X		\$137
Window, Rear	914-6125-2-TNT	1/8"		X	X	X			X		\$390

WINDOWS FOR AFTERMARKET DRAG RACING BODIES

THICKNESS
OVERSIZE
PRECUT TO FIT
BEVELED
DRILLED
COUNTERSUNK
BLACK OUT
SPECIAL ORDER

PONTIAC GXP

Windshield	924-6345-2	1/4"		X	X					\$481
Windshield	924-6335-1	3/16"	X							\$344
Windshield	924-6335-2	3/16"		X	X					\$369
Windshield	924-6325-1	1/8"	X							\$344
Windshield	924-6325-2	1/8"		X	X					\$383
Window, Door, left or right	924-6225LorR	1/8"	X							\$131
Window, Door, left or right	924-6225-2LorR	1/8"		X	X					\$143
Window, Quarter, left or right	924-6525LorR	1/8"	X							\$98
Window, Quarter, left or right	924-6525-2LorR	1/8"		X	X	X				\$110
Window, Rear	924-6125	1/8"	X							\$286
Window, Rear	924-6125-2	1/8"		X	X	X				\$311

DRAGSTER WINDOWS

Windshield, wide, 12" tall	931-6325-2M	1/8"	X							\$221
Windshield, standard, 12" tall	931-6325-1	1/8"	X							\$221
Windshield, standard, 9" tall	931-6325-1A	1/8"	X							\$198
Windshield, standard, 7" tall	931-6325-1B	1/8"	X							\$179

(WINDSHIELDS ARE 18" WIDE ACROSS THE BOTTOM. STANDARD WINDSHIELDS ARE 14" WIDE ACROSS THE TOP. WIDE WINDSHIELDS ARE 16" WIDE ACROSS THE TOP)

FACTORY X CAMARO

Windshield	61131-63332	3/16"		X	X					\$490
Window, Door, left or right	61131-62202LorR	1/8"	X							\$144
Window, Door, left or right	61131-62232LorR	1/8"		X	X					\$210
Window, Quarter, left or right	61131-65242LorR	1/8"		X	X					\$42
Window, Rear	61131-61202	1/8"	X							\$353
Window, Rear	61131-61242	1/8"		X	X					\$342

FACTORY X CAMARO (TINTED)

Window, Door, left or right	61131-62204LorR	1/8"	X						X	\$180
Window, Rear	61131-61204	1/8"	X						X	\$441

FACTORY X MUSTANG

NEW!

Windshield	61321-63332	3/16"		X	X					\$490
Window, Door, left or right	61321-62232LorR	1/8"		X	X					\$210
Window, Quarter, left or right	61321-65242LorR	1/8"		X	X	X				\$42
Window, Rear	61321-61242	1/8"		X	X	X				\$342

FUNNY CAR CHEVROLET IMPALA

Windshield	933-6335-2	3/16"		X	X					\$402
Window, Door, left or right	933-6225-2LorR	1/8"		X	X					\$110
Window, Door, left or right	933-6235-2LorR	3/16"		X	X					\$125

FUNNY CAR CHEVROLET MONTE CARLO

Windshield	930-6335-2	3/16"		X	X					\$286
Window, Door, left or right	930-6225-2LorR	1/8"		X	X					\$110

WINDOWS FOR AFTERMARKET DRAG RACING BODIES

OPTIONS

THICKNESS	OVERSIZE	PRECUT TO FIT	BEVELED	DRILLED	COUNTERSUNK	BLACK OUT	SPECIAL ORDER
-----------	----------	---------------	---------	---------	-------------	-----------	---------------

FUNNY CAR DODGE CHARGER

Windshield	932-6335-2	3/16"		X	X					\$402
Windshield	932-6345-2	1/4"		X	X					\$508
Window, Door, left or right	932-6225-2LorR	1/8"		X	X					\$110
Window, Door, left or right (HAS FIRE HOLE)	932-6235-2LorR	3/16"		X	X					\$125

FUNNY CAR FORD MUSTANG

Windshield	929-6335-2	3/16"		X	X					\$286
Window, Door, left or right	929-6225-2LorR	1/8"		X	X					\$110

FUNNY CAR TOYOTA SUPRA

Windshield, Laminated	68731-63558	.265"		X						\$920
Window, Door, pair (has fire hole)	68731-62352 REV 1	3/16"	X							\$380
Window, Door, pair (has fire hole)	68731-62252 REV 1	1/8"	X							\$242
Window, Door, pair	68731-62252	1/8"	X							\$242

UNIVERSAL AFTERMARKET RACING WINDOWS

OPTIONS

THICKNESS	OVERSIZE	PRECUT TO FIT	BEVELED	DRILLED	COUNTERSUNK	BLACK OUT	SPECIAL ORDER
-----------	----------	---------------	---------	---------	-------------	-----------	---------------

UNIVERSAL AFTERMARKET (CLEAR)

Windshield	324-6345-ST	1/4"	X							\$616
Windshield	324-6335-ST	3/16"	X							\$462
Windshield	324-6325-ST	1/8"	X							\$399
Windows, Door, pair	000-6235	3/16"	X							\$428
Windows, Door, pair	000-6225	1/8"	X							\$328
Windows, Door, pair	000-6215	.093"	X							\$280

*SEE POLYCARBONATE FLAT SHEETS FOR WINDOW, REAR

UNIVERSAL AFTERMARKET (TINTED)

Windows, Door, pair	000-6225DT	1/8"	X							\$354
Window, Quarter, left or right	000-6502DT	1/8"	X							\$105
Window, Rear	324-6125DT	1/8"	X							\$370

UNIVERSAL AFTERMARKET WINDSHIELD

PART NUMBER: 324-63x5-ST

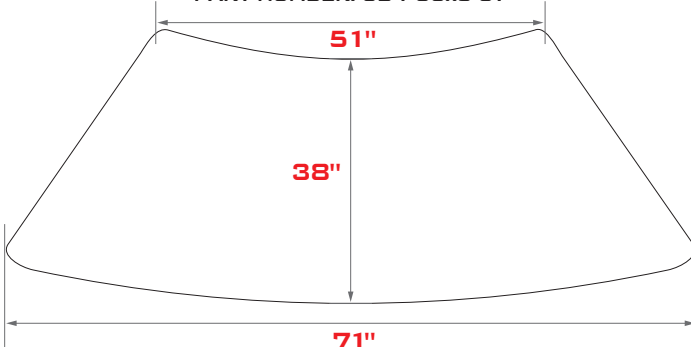

UNIVERSAL AFTERMARKET DOOR WINDOW

PART NUMBER: 000-62x5

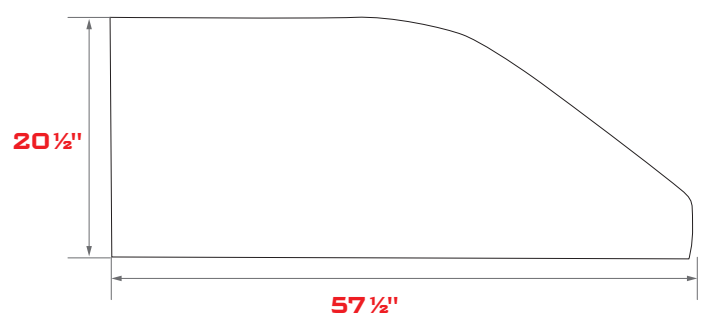

ENGINEERED THROUGH THE DRIVER'S EYES



BODY MOUNTING TOOLS, BRACING & ACCESSORIES

PRODUCTS ESSENTIAL FOR A COMPLETE,
PROFESSIONAL LOOKING RACECAR



- » **MOUNTING TOOLS:** Ensure a professional body installation and easily replace panels throughout the season with a quick, hassle-free process
- » **UNIVERSAL BRACING:** Support body panels with these lightweight components essential to achieving astounding aerodynamics
- » **ACCESSORIES:** Everything you need to give your racecar that extra finishing touch!

FIVE STAR PREMIUM AVEX STYLE MULTI-GRIP RIVETS

- » Five Star Rivets have a super-tight grip & won't spin while drilling
- » Grip range of up to 3/16" for 1/8" rivets & up to 1/2" for 3/16" rivets
- » Use long shank rivets for fastening fender, door, & windshield post together
- » Sold in quantities of 100 & 500; large head & small head with choice of 1/8" unpainted or 3/16" unpainted, white, black, blue, or red



SIZE/DESCRIPTION	QTY	SMALL	LARGE	
3/16", color	100	814x-100S	814x-100L	\$17
3/16", unpainted	100	816-100S	816-100L	\$17
3/16" long shank	100	816A-100S	N/A	\$19
3/16", color	500	814x-500S	814x-500L	\$53
3/16", unpainted	500	816-500S	816-500L	\$53
1/8", unpainted	100	815-100S	815-100L	\$13
1/8", unpainted	500	815-500S	815-500L	\$48

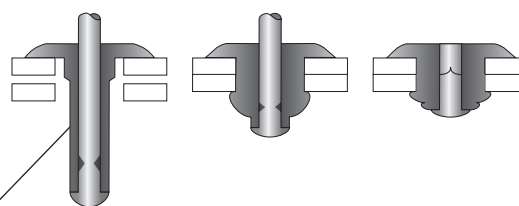

Provide a secure installation of your body panels with Five Star Rivets & Washers!

Five Star Rivets pull much tighter than other, cheaper rivets.

Washers are oversized to fit with Five Star Rivets and keep rivets tight no matter how much vibration

FIVE STAR PREMIUM WASHERS

- » Five Star Premium Washers are lightweight & available in 3 sizes
- » Recommended for all plastic & composite body panels to keep them tight & prevent rivets from pulling out

TYPE	SIZE (I.D.)	SIZE (O.D.)	QTY		
Standard	1/8"	3/8"	100	817-100A	\$9
Standard	1/8"	3/8"	500	817-500A	\$25
Standard	3/16"	1/2"	100	818-100A	\$9
Standard	3/16"	1/2"	500	818-500A	\$25
Large	3/16"	3/4"	100	818-100AL	\$9
Large	3/16"	3/4"	500	818-500AL	\$25

HIGH-IMPACT PLASTIC WEAR STRIPS

- » Height adjustable to seal the nose to the track to optimize aero & protection from wear
- » CNC-machined from Five Star's exclusive durable plastic
- » 2-piece kit fits either side
- » Install with Five Star Universal Body Mounting Kits
- » Available in 10 colors **-W -B -CB -R -Y -OR -FG -FO -FR -FY**

ABC NextGen, NextGen Late Model Stock Car	116" x 1-7/8"	11002-41551-x	\$35
ABC, LMSC, Straight-up Metal, Dirt Grand National	112" x 2-3/4"	000-400-x	\$35
S2 Sportsman	101" x 3"	664-400-x	\$42
Classic Street Stock (N/A IN FLUORESCENT COLORS)	120" x 5"	600-400-x	\$41
MD3 Street Stock, '88 Monte Carlo	119" x 3"	021-400-x	\$41
Modern Style Street Stock, North American Sportsman	107" x 3"	20002-41551-x	\$38

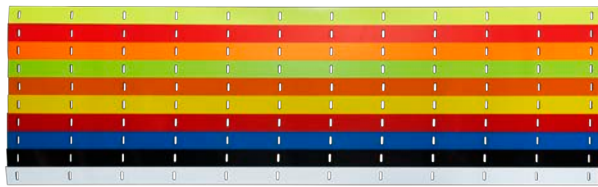

11002-41551-X

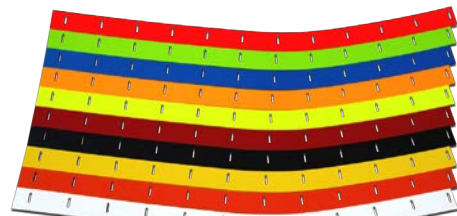

000-400-X



11002-41551-Y YELLOW WEAR STRIPS FULLY INSTALLED WITH 00001-72651 UNIVERSAL BODY MOUNTING KIT

KITS SPEED UP WEAR STRIP INSTALLATION & ALLOW FOR ADJUSTABILITY OF WEAR STRIP IF NEEDED



FULLY ASSEMBLED PLASTIC

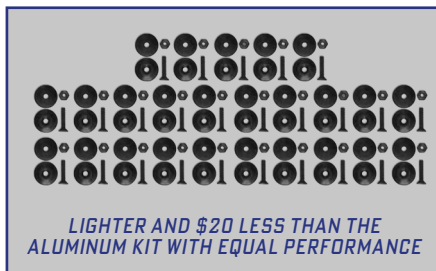

LIGHTER AND \$20 LESS THAN THE ALUMINUM KIT WITH EQUAL PERFORMANCE



FULLY ASSEMBLED ALUMINUM

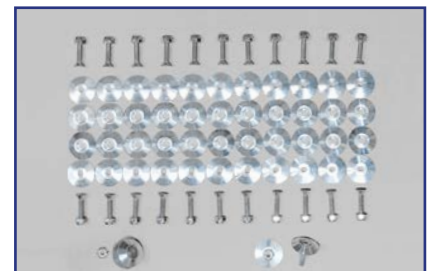

UNIVERSAL BODY MOUNTING KITS

- » Universal fit that can be used anywhere on a racecar
- » Plastic Kit comes in all black & features Delrin washers that withstand repeated impact & stress
- » **Aluminum Kit includes:** 25 lightweight machined aluminum inner & outer 1" diameter washers, 25 nuts & 25 bolts. Kit weighs 12 oz
- » **Plastic Kit includes:** 25 ultra-durable plastic inner & outer 1" diameter washers, 25 lightweight aluminum nuts & 25 bolts. Kit weighs 7 oz

Aluminum: 25 sets (FULL INSTALLATION)	000-400K	\$49
Plastic: 25 sets (FULL INSTALLATION)	00001-72651	\$29

PRICING SUBJECT TO CHANGE WITHOUT NOTICE

FRONT BUMPERS

- » Formed using CNC progressive tube bending technology
- » Fits the exact contour of Five Star noses for maximum protection and ease of installation
- » Formed from 1-3/4" OD round steel tubing
- » For a complete secure mount, it is recommended to install your bumpers with Five Star's Front Bumper Mounting Kits

ABC NEXTGEN		
Front, .065" steel	11002-71182	\$48
Front, .095" steel	11002-71185	\$48
Front, .095" steel (12" EXT RIGHT SIDE)	11002-71188	\$56
NEXTGEN LATE MODEL STOCK CAR		
Front, .065" steel	13002-71182	\$48
Front, .095" steel	13002-71185	\$48
Front, .095" steel (12" EXT RIGHT SIDE)	13002-71188	\$56
ORIGINAL ABC / ORIGINAL LMSC / STRAIGHT-UP METAL		
Front, .065" steel	660-7103	\$48
Front, .095" steel	660-7103B	\$48
Front, .095" steel (12" EXT RIGHT SIDE)	660-7103C	\$56

NORTH AMERICAN SPORTSMAN		
Front .065" steel	20002-71182	\$48
STREET STOCK '88 MONTE CARLO		
Front, .065" steel	600-7103	\$48
Front, .095" steel	600-7103B	\$48
Front, .065" steel	600-7101 (SQUARE)	\$48
STREET STOCK MD3 CAMARO, MUSTANG & CAMRY		
Front, .065" steel	20002-71182	\$48
DIRT GRAND NATIONAL		
Front, .065" steel	700-7103	\$48
Front, .095" steel	700-7103B	\$48
SHORT TRACK TRUCK COMMON		
Front, .065" steel	21001-71162	\$48

FRONT BUMPER MOUNTING KIT (HIGHLIGHTED IN ORANGE) WITH BLACK ADJUSTABLE BUMPER SUPPORTS



.095" STEEL BUMPER WITH
12" EXTENSION FOR
ADDITIONAL RIGHT FRONT
PROTECTION

NEW!
LIGHTWEIGHT EXTRUDED ALUMINUM



CLOSE-UP OF
ADJUSTABLE
BUMPER SUPPORT

FRONT BUMPER MOUNTING KITS

- » Everything you need to mount the bumper to the chassis
- » Upgraded lightweight, extruded, black anodized aluminum adjustable bumper supports
- » Make quick, easy, & accurate adjustments with a 5/8" wrench
- » Universal design for all Five Star Short Track Noses
- » Fits all chassis configurations
- » **Complete Kit includes:** 2 aluminum threaded bumper support tubes; 4 clevis, eye bolts & nuts; 2 1-1/2" pieces of square tubing, notched on one end; 2 pieces of flat stock; 4 1-1/2" bolts & stover nuts, 2 pivoting chassis mounts with 2-1/2" bolts & nuts
- » **Adjustable Bumper Support Kit includes:** 2 extruded, threaded, black anodized aluminum adjustable tubes; 4 eye bolts & nuts; 4 1-1/2" bolts and stover nuts
- » **Replacement Kit includes:** 2 1-1/2" square pieces of square tubing; 2 pieces of flat stock; 1/2" nuts & bolts & mounting tabs

Complete Kit	10001-72721	\$132
Adjustable Bumper Support Kit	10001-72733	\$35
Replacement Kit	802-4	\$87

10001-72721 | COMPLETE KIT

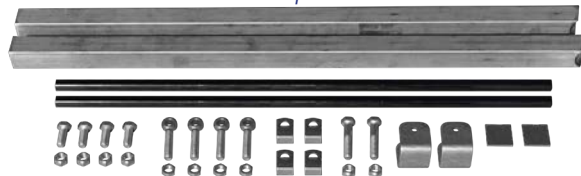

10001-72733 | ADJUSTABLE BUMPER SUPPORTS KIT



802-4 | REPLACEMENT KIT



HOOD PIN BRACKETS

- » Preformed to fit the nose & hood precisely
- » Aluminum option weighs less than half of steel option
- » Both options include welded-on tabs for hood pin placement
- » Aluminum bracket includes welded on mounting tabs on each end to brace to the front bumper mounting kit for added support
- » ABC NextGen / NextGen Late Model Stock Car require 4 hood pins & Older Style ABC and Older Style LMSC require 5 hood pins
- » Available in 1/2" & 3/4" options, & will work with both 1/2" & 3/8" hood pins

ABC NEXTGEN / NEXTGEN LATE MODEL STOCK CAR		
3/4" OD, aluminum (COMMON)	11002-34333	\$66
3/4" OD, steel (COMMON)	11002-34331	\$35
ORIGINAL ABC / ORIGINAL LATE MODEL STOCK CAR		
3/4" OD, aluminum (EXCLUDES FORD)	660-411A-HPB	\$66
3/4" OD, aluminum (FORD)	570-411A-HPB	\$66
3/4" OD, steel (EXCLUDES FORD)	660-411-HPB	\$35
3/4" OD, steel (FORD)	570-411-HPB	\$35
1/2" OD, steel (EXCLUDES FORD)	660-410-HPB	\$35
1/2" OD, steel (FORD)	570-410-HPB	\$35
NORTH AMERICAN SPORTSMAN		
3/4" OD, steel	20002-34331	\$35

S2 SPORTSMAN		
3/4" OD, steel	664-411-HPB	\$35
1/2" OD, steel	664-410-HPB	\$35
SHORT TRACK TRUCK		
1/2" OD, steel (COMMON)	21001-34131	\$35
STREET STOCK		
3/4" OD, steel ('88 MONTE CARLO)	600-410-HPB	\$35
3/4" OD, steel (CAMARO, MUSTANG & CAMRY)	20002-34331	\$35
DIRT GRAND NATIONAL		
1/2" OD, steel (EXCLUDES FORD)	700-410-HPB	\$35
1/2" OD, steel (FORD)	703-410-HPB	\$35

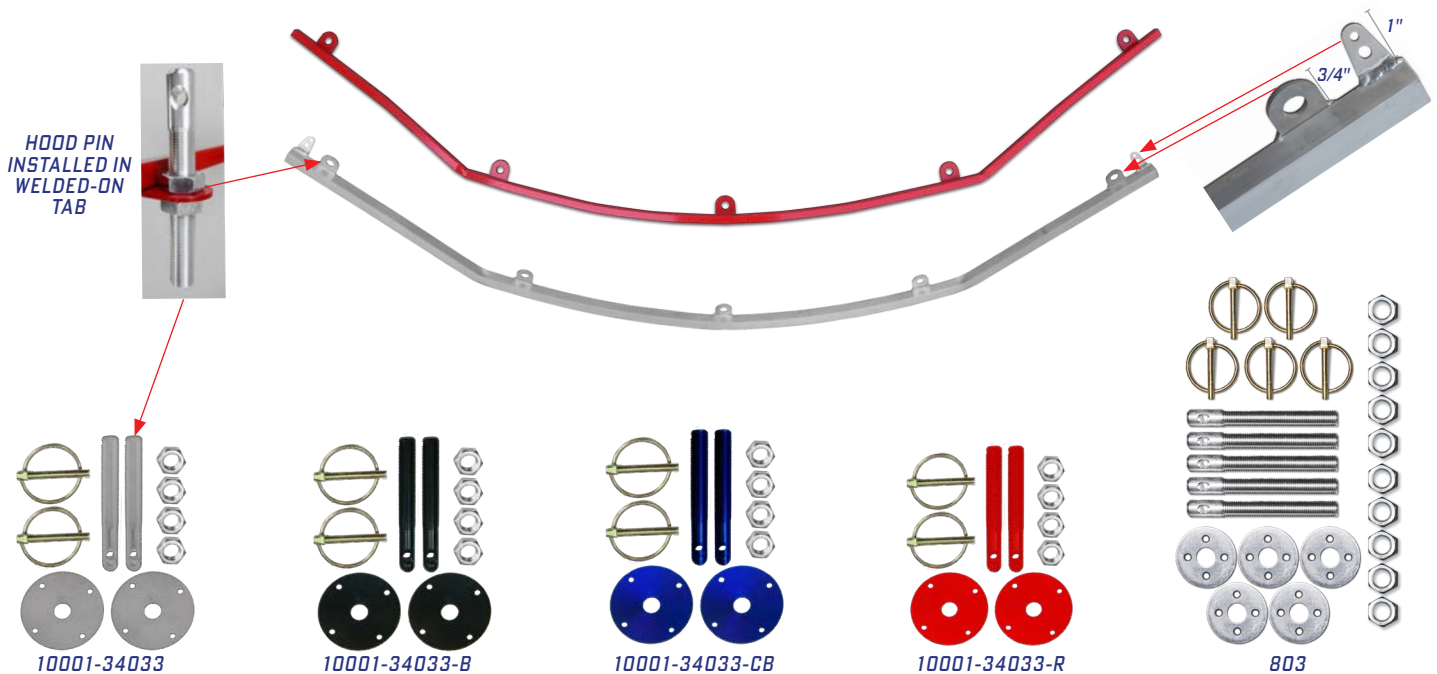

HOOD PIN KITS

- » **Secure your hood in style!**
- » 3/8" Hood Pin Kit: 2 pack kit includes: 2 lightweight anodized & gun-drilled aluminum pins (half the weight of standard), 2 aluminum scuff plates, 2 flip-over steel clips, 4 jam nuts
- » 1/2" Hood Pin Kit: 5 pack kit includes: 5 lightweight aluminum pins, 5 aluminum scuff plates, 5 flip-over style steel clips, 10 jam nuts

3/8" Hood Pin Kit, Silver	10001-34033	\$16
3/8" Hood Pin Kit, Black	10001-34033-B	\$16
3/8" Hood Pin Kit, Blue	10001-34033-CB	\$16
3/8" Hood Pin Kit, Red	10001-34033-R	\$16
1/2" Hood Pin Kit, 5 pack	803	\$38
1/2" Scuff Plate, aluminum	803-PS	\$2

PRICING SUBJECT TO CHANGE WITHOUT NOTICE

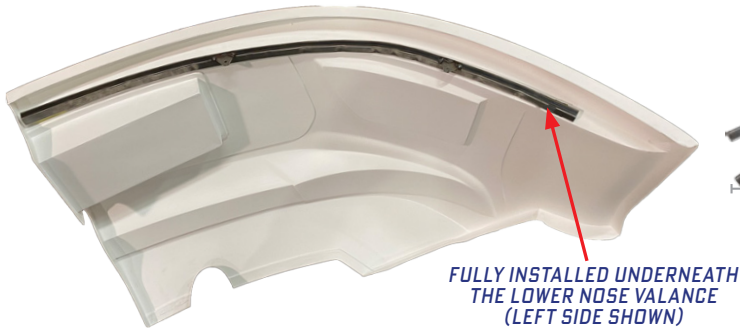

FULLY INSTALLED UNDERNEATH THE LOWER NOSE VALANCE (LEFT SIDE SHOWN)



ALUMINUM
11002-75733

42-1/2"

LOWER NOSE SUPPORT BRACKET

- » Mounts under the lower valance to maintain strength & structural integrity for the nose under high speeds
- » Choose from lightweight aluminum or steel bracket
- » Fits left & right half of nose
- » 2-piece kit includes: 2 brackets with 2 attached mounting tabs for ease of installation

Aluminum	11002-75733	\$49
Steel	11002-75731	\$44

FITS THESE BODY STYLES: ABC NEXTGEN AND NEXTGEN LATE MODEL STOCK CAR



000-500: MOUNT TO INSIDE OF WEAR STRIPS WITH A FIVE STAR UNIVERSAL BODY MOUNTING KIT



11002-75333: MOUNT VERTICALLY ON NOSE SIDE

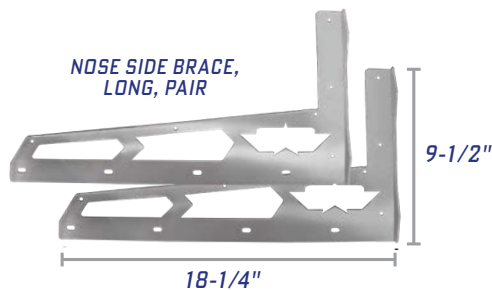

NOSE SIDE BRACE,
LONG, PAIR

9-1/2"

18-1/4"

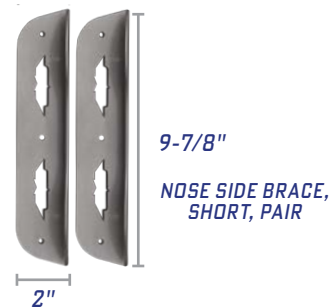

9-7/8"

NOSE SIDE BRACE,
SHORT, PAIR

2"

ALUMINUM NOSE SIDE BRACES

- » Provides structure to an aero critical part of the car
- » Laser-cut aluminum is pre-drilled for riveting to the nose & for mounting body braces
- » Works great with Five Star's Premium Adjustable Body Braces (PN 10001-759XX ON PAGE 165)
- » Each pair weighs less than a pound

Nose Side Brace, Long, pair	000-500	\$39
-----------------------------	---------	------

FITS THESE BODY STYLES: OLDER STYLE ABC AND OLDER STYLE LMSC, FIBERGLASS SPORTSMAN, STRAIGHT UP METAL, DIRT GRAND NATIONAL, MINI STOCK MUSTANG

Nose Side Brace, Short, pair	11002-75333	\$15
------------------------------	-------------	------

FITS THESE BODY STYLES: ABC NEXTGEN, NORTH AMERICAN SPORTSMAN, NEXTGEN LATE MODEL STOCK CAR, SHORT TRACK TRUCK

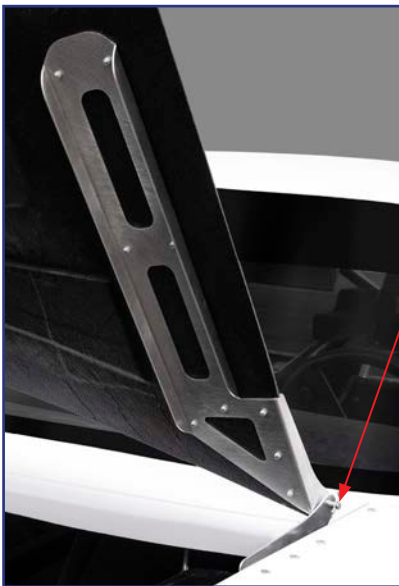

FULLY INSTALLED 11002-73333



FULLY INSTALLED 000-33H

ALUMINUM HOOD HINGE KITS

- » Hinged hoods create easy access to the engine compartment
- » Long Hinge Kit includes: Laser cut aluminum hinge, pin, & clip assembly. 1 kit is required to complete the installation of a hood
- » Short Hinge Kit includes: Laser cut aluminum hinge, pin, & clip assembly. 2 kits are required to complete the installation of a hood

Hood Hinge, short	000-33H	\$17
Hood Hinge, long	11002-73333	\$39
Replacement Pin & Clip	000-33HP	\$5

ALUMINUM HOOD PROP

- » Makes for the easiest access to the engine compartment
- » Made of machined lightweight aluminum
- » Used for hinged hoods
- » Sold as a pair, 2 needed for installation

Hood Prop, pair	000-3400	\$67
-----------------	----------	------



FULLY INSTALLED 000-3400



000-409 FULLY INSTALLED



STREET STOCK
FLEXIBLE RADIATOR DUCT

FLEXIBLE RADIATOR DUCTS

- » Retains air flow functionality even after frontal impact & reduces the risk of radiator damage
- » Flexible Radiator Duct replaces rigid metal ductwork with a custom canvas bag & aluminum or plastic framing
- » Long lasting & durable
- » Simple installation
- » Select your model by measuring the size of the radiator core
- » Features molded plastic radiator mounting flanges
- » Plastic Nose Air Inlet Extension (PN 000-409-NP) used for 000-409 Radiator Ducts only

Street Stock (PN 600-409)

- » Fits both '88 Monte Carlo Noses
- » Captures air from both the upper & lower nose grill openings

ABC/NORTH AMERICAN SPORTSMAN/S2/SU		STYLE/SIZE	ABC NEXTGEN/NEXTGEN LMSC	
000-409-1	\$169	Griffin, 22-3/8" x 17-7/8"	11002-42120	\$135
000-409-2	\$169	Howe, 24-1/4" x 18-1/2"	11002-42121	\$135
000-409-3	\$169	Howe, 22-1/4" x 18-3/4"	11002-42122	\$135
000-409-4	\$169	C & R, 22-1/4" x 17-3/4"	11002-42123	\$135
000-409-5	\$169	C & R, 24-1/4" x 17-3/4"	11002-42124	\$135
000-409-6	\$169	Howe, 27-1/4" x 18-1/2"	11002-42125	\$135
LMSC		STYLE/SIZE	STREET STOCK	
000-409-5	\$169	C & R, 24-1/4" x 17-3/4"	600-409-2	\$156
000-409-6	\$169	Howe, 27-1/4" x 18-1/2"	600-409-6	\$156

PLASTIC BRAKE DUCT KIT

- » Provide peak airflow to cool your brakes
- » Universal fit for all noses at correct angle; fits either side
- » Fits 3" & 4" Brake Duct hose
- » Crimped 3/16" stainless steel screen to keep debris out
- » Kit includes: pre-cut stainless steel screen, rivets & washers
- » Weighs 6 oz

Brake Duct Kit 000-412D \$35

FITS THESE BODY STYLES: ABC NEXTGEN, ABC, NEXTGEN LMSC, LMSC, S2, SHORT TRACK TRUCK, NORTH AMERICAN SPORTSMAN, STRAIGHT-UP METAL, STREET STOCK



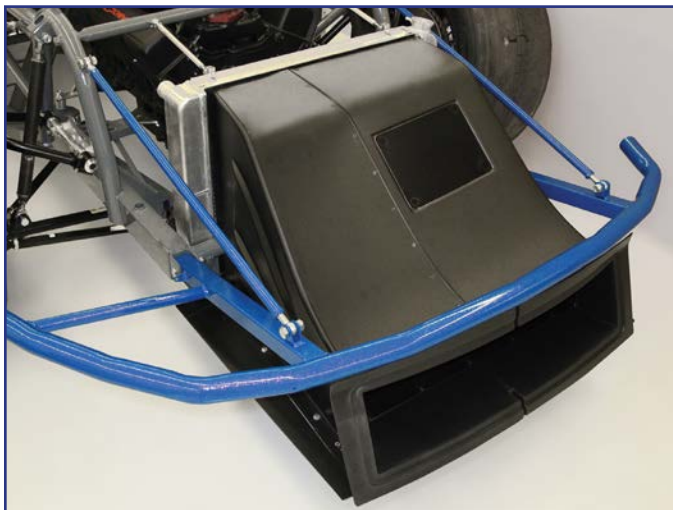

000-408 FULLY INSTALLED

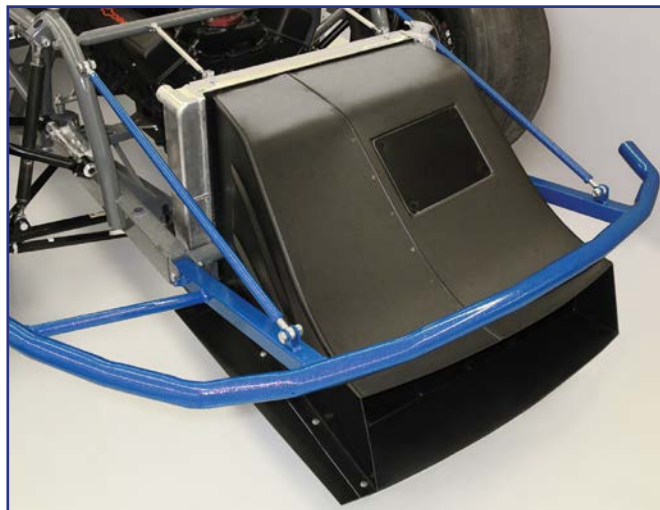

11002-42151 FULLY INSTALLED

MOLDED PLASTIC RADIATOR DUCTS

- » Universal multi piece design for easy installation to fit any chassis and radiator size/offset
- » High air flow design
- » Premium molded plastic weighs less than 13 lbs
- » More durable and easier to install than other sheet metal air boxes
- » 100% positive seal from nose to radiator
- » Access panel for easy debris clean-out
- » **Kit includes:** 2-piece molded plastic radiator duct, 1 molded plastic bottom, 1 aluminum cover kit with 4 black rivets, 1 plastic nose air inlet extension, and 1 molded plastic frame *(THE PLASTIC NOSE AIR INLET EXTENSION IS FOR THE UNIVERSAL SHORT TRACK BODY. IT IS NOT NEEDED FOR ABC NEXTGEN AND NEXTGEN LATE MODEL STOCK CAR)*

Universal Short Track Bodies*	000-408	\$221
ABC NextGen / NextGen Late Model Stock Car	11002-42151 <i>(AIR INLET EXTENSION NOT REQUIRED)</i>	\$185
Radiator Duct, 2-piece	000-408-D	\$68
Radiator Duct, Bottom	000-408-B	\$54
Radiator Duct, Cover Kit	000-408-A	\$15
Radiator Duct, Frame	000-408-R	\$36

*FITS THESE BODY STYLES: OLDER STYLE ABC, OLDER STYLE LMSC, NORTH AMERICAN SPORTSMAN, S2 SPORTSMAN, STRAIGHT-UP METAL, STREET STOCK



PLASTIC NOSE AIR INLET EXTENSION

- » Ideal for racers who build their own aluminum radiator box
- » Molded Plastic construction weighs less than 2 lbs
- » The Plastic Nose Air Inlet Extension is not needed for the ABC NextGen & NextGen Late Model Stock Car
- » Item already included with 000-408 Molded Plastic Radiator Duct & 000-409 Flexible Radiator Duct

Plastic Nose Air Inlet Extension	000-409-NP	\$36
----------------------------------	------------	------

FITS THESE BODY STYLES: ABC, LMSC, NORTH AMERICAN SPORTSMAN, S2 SPORTSMAN, STRAIGHT-UP METAL



SHOWN MOUNTED FROM INSIDE OF NOSE



PRICING SUBJECT TO CHANGE WITHOUT NOTICE

COWL INDUCTION COLD AIR BOXES

FLOW BENCH TESTED FOR PEAK AIRFLOW

- » Advanced lightweight composite construction with flame retardant gray resin
- » Comparable in weight to carbon fiber alternatives
- » Designed for maximum airflow using air filters as short as 3"
- » Increased distributor & under hood clearance
- » Fits a standard 14" filter element

4 Barrel, 0° Angle (Offset)	10001-53401	\$564
4 Barrel, 3° Angle (Standard)	10001-53431	\$564
2 Barrel, standard	10001-53201	\$426
2 Barrel, offset	10001-53202	\$406

NOTE: FOR OLDER STYLE 51-SERIES COLD AIR BOXES CALL FIVE STAR 262.877.2171



FULLY INSTALLED COLD AIR BOX



2 BARREL COLD AIR BOX

4 BARREL AIR BOXES:

- » Available in 0° & 3° to ensure a proper, level fit
- » Feature a patented machined adapter ring for clean airflow, better fit, & durability
- » 3° Air box is commonly used for short track late models
- » How to determine air box angle option:
 - » Set car at proper ride height
 - » Place angle finder on carburetor to determine which air box option fits best



4 BARREL COLD AIR BOX

2 BARREL OFFSET AIR BOX:

- » Offset 2-barrel air box is for engines with a larger setback
- » Designed to allow the element to be flat across the back for engine setback & clearance in the cowl
- » Fits a standard 3-1/2" x 14" filter element

2 BBL AIR BOX IS DYNO TESTED

"The results were outstanding! Five Star's 2bbl Air Box was 10 HP & 16 ft lbs of torque better than the old one!"

-SHANE HARDING
HARDING MOTORSPORTS CHASSIS

PATENTED FLOW DESIGN 4 BBL UNIQUE HIGH FLOW DESIGN

CNC-machined aluminum ring (laminated into the air box) fits perfectly on carburetor to maximize airflow

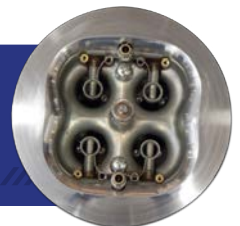

SCAN HERE TO  SHOP ONLINE

» FOR INDIVIDUAL PART DIMENSIONS, VISIT FIVESTARBODIES.COM

REFLECTIVE HEAT SHIELD

- » Thin reflective adhesive film reflects over 90% of radiant heat from the engine, up to 500°F
- » Easy to cut and install to protect any part of the racecar from high heat:
 - » All Cold Air Boxes
 - » Foot Boxes
 - » Fuel Filter Housings
 - » Interiors
 - » Shock Canisters
 - » And more

Cold Air Box Kit, 4 oz	000-52HS	\$74
5'x26" Sheet, 3oz per ft	000-5HS	\$74



FULLY INSTALLED
COLD AIR BOX KIT
000-52HS

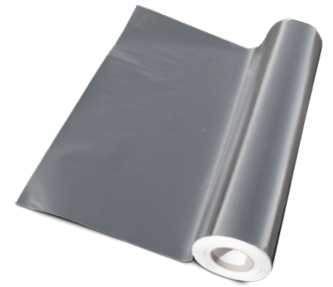

5' LENGTH X 26" WIDE SHEETS
000-5HS

COWL AIR INSERT

- » Designed for maximum airflow directly into the cold air box
- » Made of Ultraglass composite and oversized for left and right adjustment to properly fit the air box
- » Opening meets all sanctioning regulations
- » Included with ABC Body Packages
- » Available in 4 colors

		-W -B	-CB -R
Cowl Air Insert	661-5100A-X	\$72	\$75

FITS THESE BODY STYLES: ABC NEXTGEN, ABC, NORTH AMERICAN SPORTSMAN, S2, STRAIGHT-UP METAL, SHORT TRACK TRUCK



COWL AIR DEFLECTORS

- » Smoothly flows air from cowl air opening into cold air box
- » Black Ultraglass Composite
- » Rounded Bottom: 20" x 7", Square Bottom: 20-1/8" x 7-1/2"
- » Fits all air box styles listed on page 154
- » 000-5100A-B available & fits older style 51-series air boxes

Rounded Bottom	000-5200A	\$59
Square Bottom	000-5100A-B	\$76



ROUNDED BOTTOM | 000-5200A



SQUARE BOTTOM | 000-5100A-B

ALUMINUM COWL BRACKET TABS

- » Create a positive seal by holding hood flat at the cowl
- » Mounts along front flange of cowl panel
- » Fits 3/8" or 1/2" hood pins
- » Kit is included with cowl panels
- » Kit includes: 4 laser-cut aluminum tabs weighing 0.5 oz each

Cowl Bracket Tabs	000-510	\$13
-------------------	---------	------



REAR BUMPERS

- » Formed using CNC progressive tube bending technology
- » Fits the exact contour of Five Star bumper covers for maximum protection and ease of installation
- » Formed from 1-3/4" OD round steel tubing
- » For a complete secure mount, it is recommended to install your bumpers with Five Star's Rear Bumper Mounting Kits

ABC NextGen, .065" steel	11002-71682	\$48
NextGen Late Model Stock Car, .065" steel	11002-71682	\$48
ABC / LMSC / Straight-Up Metal, .065" steel	570-7503	\$48
North American Sportsman, .065" steel	11002-71682	\$48

Street Stock '88 Monte Carlo, .065" steel	600-7501	\$48
Dirt Grand National, .065" steel	570-7503	\$48
Short Track Truck, .065" steel	T000-7503	\$48

**REAR BUMPER FULLY INSTALLED WITH HEIGHT ADJUSTABLE MOUNTING KIT
(HIGHLIGHTED IN ORANGE)**

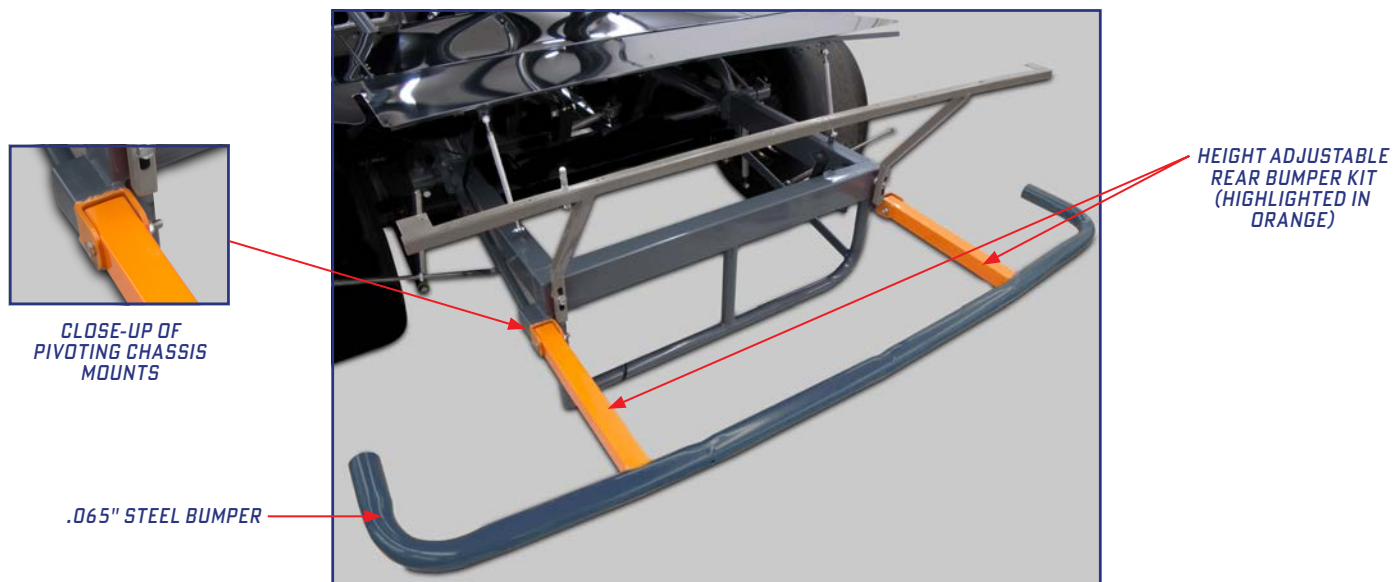

802-2S | HEIGHT ADJUSTABLE



802-2 | NON-ADJUSTABLE

REAR BUMPER MOUNTING KITS

- » Everything you need to mount the bumper to the chassis
- » Universal design for all Five Star Short Track Bumper Covers
- » Fits all chassis configurations
- » Available in two options:
- » **Height-Adjustable Kit: (PN 802-2S)** Allows for several different mounting options and pivots to allow precise adjustments to the height of the rear bumper cover
Kit includes: 2 pivoting chassis mounts; 1 36" long 1-1/2" square piece of tubing; 2 pieces of flat stock; 2 1/2" nuts and bolts
- » **Non-Adjustable Kit: (PN 802-2)** Make your bumper a bolt-on component
Kit includes: 2 3' long x 1-3/4" thick pieces of round tubing, 2 pieces of .120" thick square tubing and 5/16" hex bolts & nuts

Height-adjustable Kit	802-2S	\$49
Non-adjustable Kit	802-2	\$43

STEEL REAR DECK MOUNTING KIT

- » Everything you need to properly fabricate a perfect fitting brace from the rear bumper cover & deck lid to the chassis
- » **Deck Lid Bracket:** (PN 660-450-DLB) supports your rear body clip by securing it to the rear bumper cover & quarter panel.
Kit includes: 2 tabs for hood pins; weighs 36 oz
- » **Deck Lid Height Slider Kit:** (PN 802-3) allows for easy adjustment of spoiler height with 3-1/2" of deck lid height adjustability.
Kit includes: 2 pieces slotted 3/4" square tubing, 3/8" hex bolts & nuts
- » **Deck Lid Hold-down Kit:** (NOT SOLD SEPARATELY) allows for a removable deck lid.
Kit includes: 1 aluminum deck lid hold-down strip, 2 mounting tabs, 4 jam nuts, 2 3/8" gun-drilled, anodized aluminum pins & scuff plates (SILVER), & 2 flip-over steel clips

Rear Deck Mounting Kit*	660-450-RDK	\$89
Replacement Deck Lid Bracket*	660-450-DLB	\$32
Replacement Deck Lid Height Slider Kit*	802-3	\$19
Replacement Deck Lid Hold-Down Strip	XM 000-310H-X	
Replacement Deck Lid Hold-Down Hardware Kit	XA 000-310H-K	

FITS THESE BODY STYLES: ABC NEXTGEN, ABC, NEXTGEN LMSC, LMSC, NORTH AMERICAN SPORTSMAN, S2, STRAIGHT-UP METAL, STREET STOCK, DIRT GRAND NATIONAL, MINI STOCK

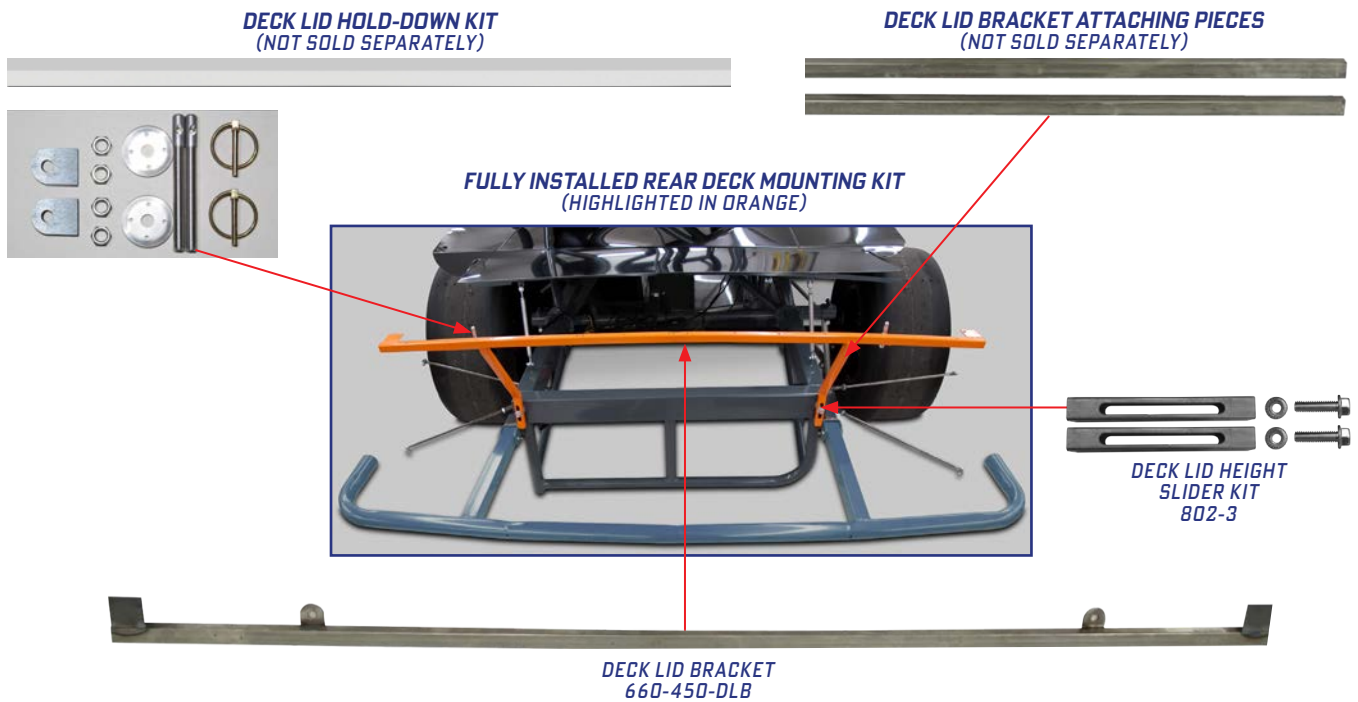

ONLY WEIGHS 17 OZ
LESS THAN HALF THE WEIGHT OF STEEL



ALUMINUM DECK LID BRACKET

- » This is a premium upgrade from the steel deck lid bracket to save weight without sacrificing strength
- » Mounts to the rear bumper cover and quarter panel, includes 2 tabs for hood pins and 4 tabs for chassis mounting options
- » Complete the combination with our 3/8" Hood Pin Kit (PN 10001-34033-X)

Aluminum Deck Lid Bracket	11002-75633	\$49
---------------------------	-------------	------

FITS THESE BODY STYLES: ABC NEXTGEN, ABC, NEXTGEN LMSC, LMSC, NORTH AMERICAN SPORTSMAN, S2, STRAIGHT-UP METAL, STREET STOCK, DIRT GRAND NATIONAL, MINI STOCK

REPLACEMENT SPOILER BRACKETS & BLADES

- » 2-piece polycarbonate blade with 2-piece aluminum bracket, your choice of unpainted or black powder-coated
- » Available in 90, 70 and 55 degree angles

ABC NextGen / NA Sportsman	5" (90°)		5" (70°)		6-1/2" (90°)		6-1/2" (70°)					
Brackets, replacement, aluminum, 60"	11002-47369-1	11002-47367-1	11002-47369-1	11002-47367-1	11002-47369-1	11002-47367-1	11002-47369-1	11002-47367-1				
Brackets, replacement, aluminum, 64-1/2"	11002-47389-1	11002-47387-1	11002-47389-1	11002-47387-1	11002-47389-1	11002-47387-1	11002-47389-1	11002-47387-1				
Brackets, replacement, aluminum, black, 60"	11002-47369-1B	11002-47367-1B	11002-47369-1B	11002-47367-1B	11002-47369-1B	11002-47367-1B	11002-47369-1B	11002-47367-1B				
Brackets, replacement, aluminum, black, 64-1/2"	11002-47389-1B	11002-47387-1B	11002-47389-1B	11002-47387-1B	11002-47389-1B	11002-47387-1B	11002-47389-1B	11002-47387-1B				
Blades, replacement, polycarbonate, 60"	11002-47359-2	11002-47357-2	11002-47359-2	11002-47357-2	11002-47359-2	11002-47357-2	11002-47359-2	11002-47357-2				
Blades, replacement, polycarbonate, 64-1/2"	11002-47479-2	11002-47477-2	11002-47479-2	11002-47477-2	11002-47479-2	11002-47477-2	11002-47479-2	11002-47477-2				
ABC / S2 / Straight-Up Metal	5" (90°)		5" (70°)		5" (55°)		6-1/2" (90°)		6-1/2" (70°)		6-1/2" (55°)	
Brackets, aluminum	661-6739-1	661-6737-1	661-6735-1	661-6739-1	661-6737-1	661-6735-1	661-6739-1	661-6737-1	661-6735-1	661-6739-1	661-6737-1	661-6735-1
Brackets, aluminum, black	661-6739-1B	661-6737-1B	661-6735-1B	661-6739-1B	661-6737-1B	661-6735-1B	661-6739-1B	661-6737-1B	661-6735-1B	661-6739-1B	661-6737-1B	661-6735-1B
Blades, polycarbonate	661-6749-2	661-6747-2	661-6745-2	661-6739-2	661-6737-2	661-6735-2	661-6739-2	661-6737-2	661-6735-2	661-6739-2	661-6737-2	661-6735-2



UNPAINTED BRACKETS WITH BLADES



BLACK POWDER-COATED BRACKETS WITH BLADES, FULLY INSTALLED USING 807-3 ADJUSTABLE BODY BRACES (SOLD SEPARATELY, SEE PG XXX)



SPOILER IS FULLY INSTALLED ON THE BUMPER COVER USING THE SPOILER MOUNTING KIT

ALUMINUM SPOILER MOUNTING KIT

- » Everything needed to mount the polycarbonate spoiler blade to the bracket, & the bracket to the bumper cover
- » **76-piece kit includes:** 32 lightweight machined aluminum inner & outer washers, 22 flat head socket screws & 22 locknuts

Spoiler Mounting Kit	000-67K	\$33
----------------------	---------	------



POLYCARBONATE RUB RAIL

- » Protect your vinyl without hiding it!
- » Attach to side of body to eliminate tire marks on fenders, doors, and quarter panels
- » Ultra-durable polycarbonate to absorb impact
- » Can be trimmed to fit your application

Rub Rail, 75" long

000-2100

\$19 ea



FULLY MOUNTED POLYCARBONATE RUB RAIL



PLASTIC VERSION INCLUDES CURVED EDGE FOR OPTIMUM AERODYNAMICS



000-5501P-W
MOLDED PLASTIC STANDARD ROCKER PANEL



ALUMINUM VERSION HAS ENDS ROLLED BY SPECIAL PROCESS, ENHANCING AIR FLOW



000-5501A-W
ALUMINUM STANDARD ROCKER PANEL



000-5500A-W
ALUMINUM STRAIGHT ROCKER PANEL

EDGES ARE LEFT STRAIGHT, NOT CURVED

MOLDED PLASTIC & ALUMINUM ROCKER PANELS

- » Mounts below the fender / door / quarter panel area and fits either side
- » Curved edges provide optimum aerodynamics and adds structural integrity to side body panels
- » Manufactured in high-impact plastic and lightweight aluminum
- » Available in 5 color options

			-W -B	-CB -R
High-Impact Plastic (N/A IN YELLOW)	000-5501P-x	82"x 5"	\$33	\$38
Aluminum	000-5501A-x	77-3/4" x 5"	\$39	\$39
Aluminum, straight	000-5500A-x	79" x 4-3/4"	\$39	n/a

FITS THESE BODY STYLES: ABC NEXTGEN, ABC, NEXTGEN LMSC, LMSC, NORTH AMERICAN SPORTSMAN, S2 SPORTSMAN, SHORT TRACK TRUCK, STREET STOCK

ALUMINUM WINDOW BRACES

- » Strongest window braces on the market
- » Designed to the exact contour of your Five Star windows
- » Made of premium high-strength aluminum with flat black powder-coated finish
- » Foam-padded surface won't scratch your windows
- » Pre-drilled holes to mount adjustable bracing from the interior dash
- » **Kit includes:** 3 aluminum braces & installation hardware

Windshield Brace Kits		C=Center, L=Left, R=Right, O=outer, all 1" Wide	
ABC Next Gen Windshield Brace Kit	11002-76333	24-1/8"(C), 24-1/4"(L), 24-1/2"(R)	\$84
NextGen Late Model Stock Car Windshield Brace Kit	13002-76333	25-5/8"(C), 25-1/2"(L), 25-5/8"(R)	\$84
ABC/LMSC/Straight-Up Metal Windshield Brace Kit	564-6301	28-5/8" x 1"	\$84
North American Sportsman Windshield Brace Kit	12001-76333	26" x 1"	\$84
Pavement Modified Windshield Brace Kit	020-6301	26-1/2" x 1"	\$84
Short Track Truck Windshield Brace Kit	21001-76333	31-5/8"(C), 31-3/4"(L), 31-1/2"(R)	\$84
Rear Window Brace Kits		C=Center, L=Left, R=Right, O=outer, all 1" Wide	
ABC NextGen Rear Window Brace Kit	11002-76133	30-7/8"(C), 30-5/8"(O)	\$84
NextGen Late Model Stock Car Rear Window Brace Kit	11002-76133	30-7/8"(C), 30-5/8" (O)	\$84
ABC/LMSC/Straight-Up Metal Rear Window Brace Kit	674-6101	32" x 1"	\$84
North American Sportsman Rear Window Brace Kit	12001-76133	31-1/4"(C), 30-1/2"(O)	\$84
Pavement Modified Rear Window Brace Kit	020-6101	34" x 1"	\$84



FULLY INSTALLED WINDOW BRACE KIT

WEIGHS LESS THAN 2 LBS



IMPORTANT:
USING RIVETS APPLIES TOO MUCH PRESSURE TO YOUR WINDOW & WILL FRACTURE THE POLYCARBONATE

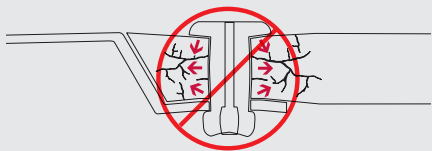

WINDOW INSTALLATION KIT

- » Using proper hardware provides the perfect fit & helps to increase the life of your window
- » Black oxide coated to prevent rust
- » Enough hardware to install a complete set of windows on one car
- » **Kit includes:** 120 6-32 1/2" & 16 6-32 3/4" flat head socket screws, 136 6-32 nylon locknuts, 1 long-arm hex key & 9/64" drill bit

Window Installation Kit	805	\$27
-------------------------	-----	------

WINDOW INSTALLATION COUNTERSINK DRILL BIT

- » 3/8" diameter steel bit, 1/4" shank
- » Use this drill bit to countersink holes perfectly for window screw installation into polycarbonate!
- » Ensures a flush fit and a secure hold every time
- » Not required for precut to fit, beveled, & drilled windows

Drill Bit	805-1	\$19
-----------	-------	------

RIGHT SIDE DOOR SUPPORT

- » Easily adjust your right side door to the proper width
- » This piece connects your right side door bar to your door
- » .080" thick aluminum laser-cut to reduce weight
- » Laser cutting allows for precise, consistent shape & weight
- » Slotted mounting holes allow for easy inner & outer door adjustments to proper width
- » Weighs under 2 lbs

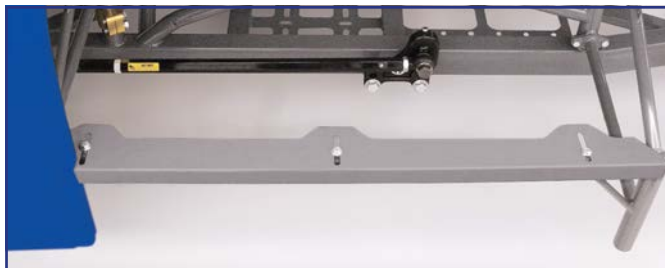

FULLY INSTALLED 11002-75533

Aluminum Door Support	11002-75533	\$30
-----------------------	-------------	------

FITS THESE BODY STYLES: ABC NEXTGEN, ABC, S2 SPORTSMAN, NORTH AMERICAN SPORTSMAN, SHORT TRACK TRUCK, DIRT GRAND NATIONAL



DRILL BIT KIT

- » Special double-ended drill bits
- » These bits drill a slightly larger diameter hole than a standard 1/8" or 3/16" bit to prevent stress cracks in the material
- » The short drill shaft makes drilling in tight places easier
- » Kit includes: 2 9/64" double-ended drill bits & 2 #30 double-ended drill bits

Drill Bit Kit	806	\$18
---------------	-----	------

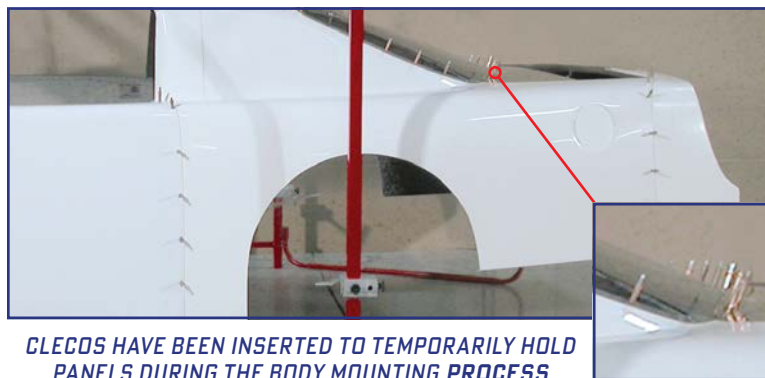

CLECOS HAVE BEEN INSERTED TO TEMPORARILY HOLD PANELS DURING THE BODY MOUNTING PROCESS

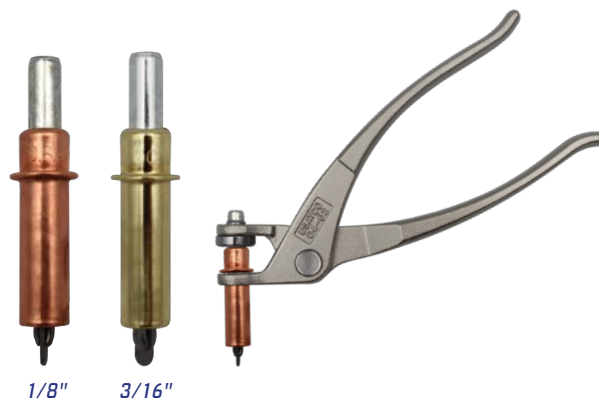

CLECO KIT & PLIERS

- » Precision has never been this easy! Cleco Pliers & Cleco Fasteners ensure perfect alignment every time
- » Clecos can be easily inserted with the Cleco Pliers to temporarily hold panels during the body mounting process
- » Our Cleco pliers are engineered for comfort & built to last, ensuring a secure grip & maximum control
- » Choice of 1/8" 25-piece Cleco Kit or 3/16" 25-piece Cleco Kit

1/8" Single Spade Kit, long	812	\$28
3/16" Single Spade Kit, long	813	\$36
Cleco Pliers	811	\$12

PRICING SUBJECT TO CHANGE WITHOUT NOTICE

FENDER-TO-NOSE BACK-UP PLATES KIT

- » Reinforces the flange where the fenders mount to the nose
- » Pre-drilled holes in the necessary locations for quick & easy mounting
- » Made of .063" thick aluminum
- » **4-piece kit includes: 2 front & 2 rear plates (ENOUGH FOR BOTH SIDES)**

ABC NextGen / NextGen LMSC / NA Sportsman	11002-75133	\$20
Other Body Styles*	000-248	\$21

*FITS THESE BODY STYLES: ABC, LMSC, S2, STRAIGHT-UP METAL, DIRT GRAND NATIONAL

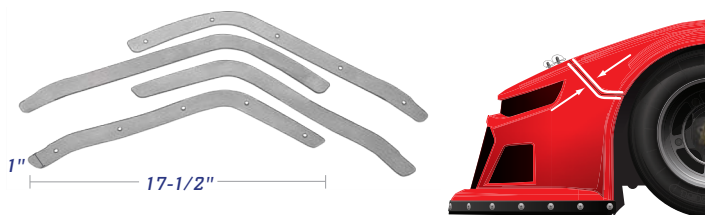

11002-75133
FOR ABC NEXTGEN, 2020 LATE MODEL STOCK CAR, NORTH AMERICAN SPORTSMAN



000-248
FOR ABC, LMSC, S2, STRAIGHT-UP METAL, DIRT GRAND NATIONAL

GREENHOUSE-TO-QUARTER PANEL BACK-UP PLATES KIT

- » Recommended for molded plastic quarter panels
- » Reinforce the flanges where the rear greenhouse meets the quarter panels
- » Universal fit for all greenhouse-style quarter panels
- » Each back-up plate is 60 X 1-12"
- » **Kit includes: 2 pre-cut aluminum strips**

2-Piece Kit	000-278	\$7
-------------	---------	-----

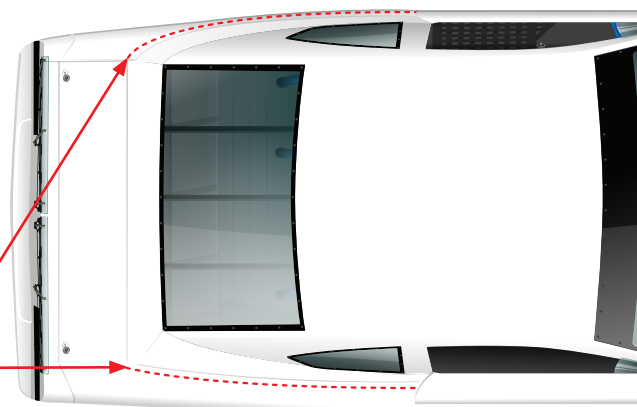

QUARTER PANEL BODY BRACE KIT

- » Stiffens the quarter panel to maintain correct shape in an aero sensitive area
- » Highly recommend bracing for tracks 1/2-mile & longer
- » Laser-cut aluminum braces have pre-drilled holes for brace attachment
- » **Kit includes: 2 braces that mount approximately 6" back from the wheel opening & 2" up from the bottom ledge**

Brace Kit, 2-Piece	11002-75433	\$39
--------------------	-------------	------

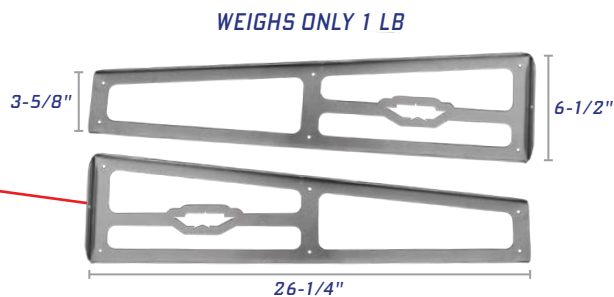
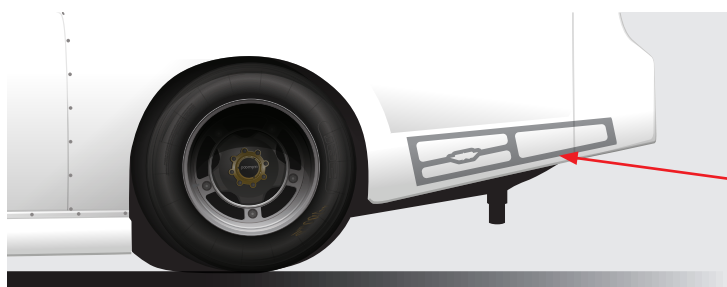

ADJUSTABLE BODY BRACES

- » Used for spoiler & roof supports & anywhere on your car to fit templates & meet other critical dimensions
- » Easy installation with ends shaped for included screw kit or 2 rivets
- » Adjustable from 8" to 10-1/2" & features durable anodized black finish & zinc-plated hardware
- » Add extra support without adding excess weight! Package of 2 weighs only 1/2 lb
- » Can also be attached to Five Star's Chassis Clamps for quick & easy adjustable bracing on your chassis

Body Braces, 2 pack 807-3 \$35



EASY INSTALLATION
WITH ENDS DESIGNED FOR
USE WITH THE INCLUDED
SCREW KIT OR 2 RIVETS



STEEL TUBING INSTALLATION KIT

- » 55 feet of .035" hard-to-find, lightweight steel tubing for any miscellaneous needs on a race car
- » Will save at least 12 lbs over standard .065" steel tubing
- » Kit includes various shapes and sizes in 60" lengths

11-pieces: 60" lengths 819 \$79

Number	Shape	Diameter	Thickness	Length
1	(3) round	3/8"	.062"	60"
2	(3) square	1/2"	.035"	60"
3	(2) round	1/2"	.062"	60"
4	(3) square	3/4"	.049"	60"

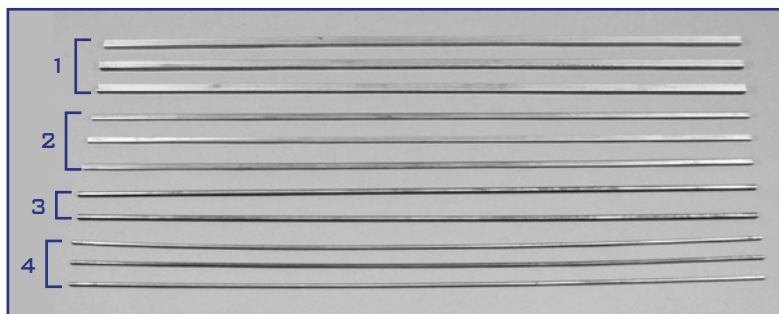

FORMED POLYCARBONATE BODY BRACES

- » Universal brace to fit any applicable area of your car
- » Each lightweight brace weighs only 7 oz
- » Absorbs impact & allows body panels to flex upon impact & return to original position & shape
- » Kit includes: 7 clear polycarbonate braces & 14 1"x2" aluminum mounting tabs

Polycarbonate Braces 804 \$33

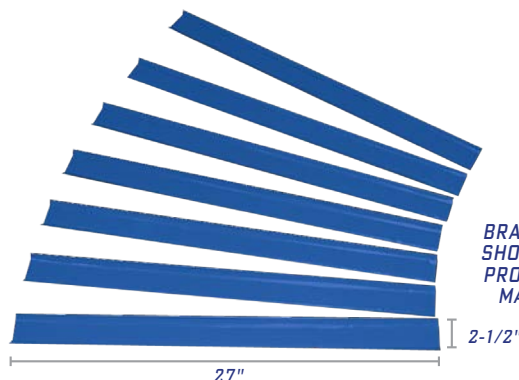

BRACES ARE
SHOWN WITH
PROTECTIVE
MASKING

ALUMINUM CUSTOM BRACING KIT

- » Build your own custom-length bracing as short as 6" or as long as 40"
- » Order as many tubing kits or end assemblies as needed to custom brace your car
- » Threaded end assemblies can be bolted, riveted, or attached with hose clamps
- » Complete kit includes: 1 aluminum tubing kit; 1 threaded end assembly kit; 1 left & 1 right 1/4-20 reusable tap
- » Aluminum Tubing kit includes: 2 7/16" x 3' hollow hex rods. Cut to desired length & can be tapped easily
- » Threaded End Assemblies kit includes: 2 right and 2 left threaded ends, 2 hose clamps that weighs 7.5 oz

Complete Kit	807	\$68
REPLACEMENT PARTS		
Tubing Kit, 2-Piece	807-1	\$29
End Assemblies, 6-Piece	807-2	\$19
Tap, left or right	807LorR	\$10

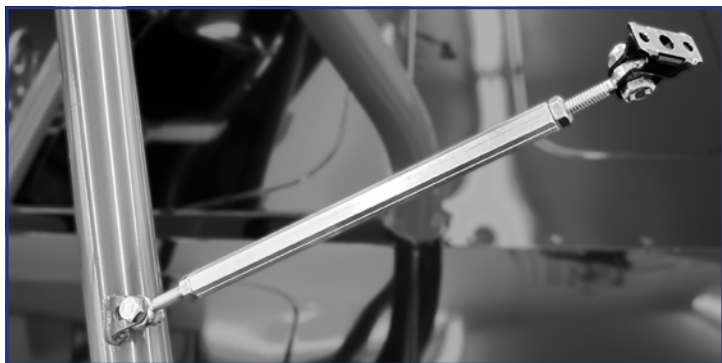

FULLY INSTALLED CUSTOM BRACE KIT



ALUMINUM TUBING | 807-1



TAP | 807L OR 807R



THREADED END ASSEMBLIES | 807-2

STEEL BODY MOUNTING TABS

- » Designed to be welded onto chassis as a universal mount for many applications
- » Makes mounting easier by positioning bracing and mounts right where you need them
- » 25-piece kit includes enough lightweight weld-on tabs to install a complete body & weighs 5 oz
- » Each tab is 1-1/8" x 1-2"
- » Use for roof, cowl, deck lid, side bracing, and more

25-Piece Kit	807-4	\$24
--------------	-------	------



CLOSE UP OF FULLY INSTALLED TAB



PREMIUM ADJUSTABLE BODY BRACES & ALUMINUM CHASSIS CLAMPS



NYLON: MOST FLEXIBLE - 5 oz ea.

ALUMINUM: LIGHTEST - 3.25 oz ea.

STEEL: MOST DURABLE - 8.25 oz ea.

PREMIUM ADJUSTABLE BODY BRACE KITS

- » Available in three options: aluminum, nylon, or steel
- » Adjustable to a maximum length of 30-1/2"
- » Stamped, black anodized aluminum mounting ends
- » Thumb screw for quick, easy length adjustments without tools
- » Kits come complete in a pack of 2

Flexible Nylon Brace Kit	10001-75951	\$33
Aluminum Brace Kit	10001-75933	\$33
Steel Brace Kit	10001-75931	\$25

ALUMINUM CHASSIS CLAMPS

- » Universal mount fits anywhere bracing is needed
- » Eliminate the need for welding or use of hose clamps when mounting body braces
- » Threaded flange / no nut required
- » Three options to fit different roll bar tubing thickness
- » Lightweight black anodized aluminum, each clamp weighs just 1.3 oz
- » Ideal for use with Five Star's Premium Adjustable Body Braces
- » **Kits include:** 2 clamps with 1/4-20 screws

1-1/2", aluminum, 2 pack	10001-74133	\$21
1-3/4", aluminum, 2 pack	10001-74333	\$21
1-5/8", aluminum, 2 pack	10001-74533	\$21



PRICING SUBJECT TO CHANGE WITHOUT NOTICE

POLYCARBONATE DOOR VENT WINDOWS

- » Molded vent windows give cars a proven performance gain in the wind tunnel over flat unmolded windows
- » Oversized and cut-to-fit options made of molded, mar-resistant coated clear .093" polycarbonate

Precut-to-fit, set of 2	11002-66222	\$38
<i>FITS THESE BODY STYLES: ABC NEXTGEN, NEXTGEN LMSC</i>		
Universal, set of 2	000-6202	\$39

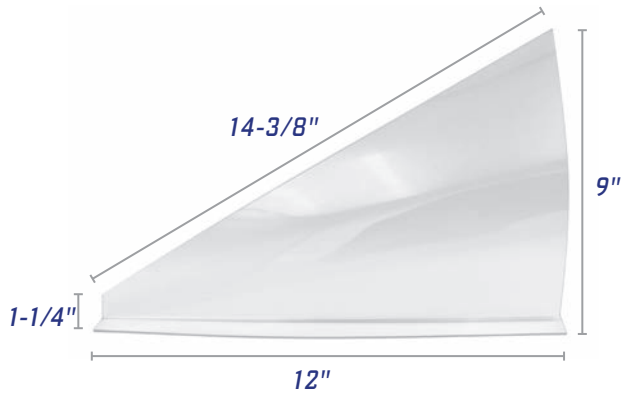

THE 11002-66222 DOOR VENT WINDOW IS CUT-TO-FIT FOR FAST & EASY INSTALLATION

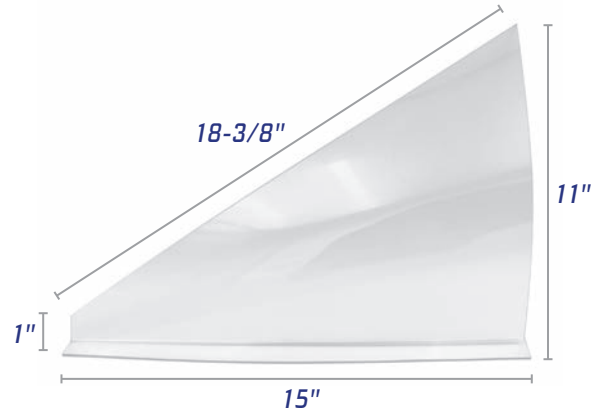

THE 000-6202 DOOR VENT WINDOW IS OVERSIZED; TRIM TO FIT YOUR APPLICATION



WIDE ANGLE RACING MIRROR

- » This convex glass mirror gives you the best view of your competition, includes a bracket kit for easy installation
- » All black frame with black anodized machined aluminum brackets
- » Only weighs 19 oz

Convex Glass Mirror	00001-85020	\$49
---------------------	-------------	------



UNIVERSAL MIRROR MOUNTING BRACKET

- » This stamped lightweight aluminum bracket allows for easy installation on any chassis
- » Satin black powder coated finish

Replacement Bracket	820-B	\$9
---------------------	-------	-----



THE PERFECT SURFACE PREP FOR PLASTIC

MD3 ADHESION PROMOTER

FAST DRYING & NON-SANDING



MD3 ADHESION PROMOTER

- » Specifically engineered adhesion promoter assures proper paint bonding to our special plastic
- » Other automotive grade primers on the market may not work at all or cause severe paint flaking
- » Improves adhesion of vinyl by enhancing the bond between adhesive on the vinyl and the substrate, for a more durable, long-lasting application
- » Comes in an aerosol spray can for quick and easy application
- » A single can coats approximately 5 individual parts

MD3 Adhesion Promoter	842	\$16
-----------------------	-----	------

» A MUST USE PRODUCT BEFORE PAINTING OR APPLYING VINYL ON ANY FIVE STAR PLASTIC PART

FIVE STAR PLASTIC WINDOW CLEANER

- » This specially formulated anti-static foaming spray contains no chemicals or abrasives that will cause damage to plastic
- » Lifts grease, grime, and wipes off fast and easy to provide a streak-free clean and clear surface finish

Window Cleaner, 19oz Can	843	\$9.95
--------------------------	-----	--------



» FIVE STAR CLEANING TIPS!

- » ALWAYS AVOID USING ABRASIVE CLEANERS & CHEMICAL SOLVENTS THAT CAN EASILY CAUSE DAMAGE TO POLYCARBONATE WINDOWS
- » USE A MICROFIBER TOWEL FOR BEST, STREAK-FREE FINISH
- » TO PREVENT SCRATCHING AND HAZING ON YOUR WINDOWS, NEVER SCRUB WITH BRUSHES OR ABRASIVE MATERIALS

PRICING SUBJECT TO CHANGE WITHOUT NOTICE

UNIVERSAL SHORT TRACK

NOSES, BUMPER COVERS & COMPONENTS

VINYL NOSE GRAPHIC ID KITS FOR A REALISTIC OEM LOOK!

PRINTED ON OUTDOOR DURABLE HIGH-TACK VINYL • GLOSS LAMINATED SURFACE PROVIDES EXCELLENT PROTECTION



CHEVROLET CAMARO

-W -B -CB -R

Nose	11132-41051-x	\$164	\$171
Nose ID Kit	11132-44141	\$39	\$39

CHEVROLET CAMARO

-W -B -CB -R

Bumper Cover	11002-45051-x	\$155	\$160
Bumper Cover ID Kit	11132-44542	\$38	\$38



'97 CHEVROLET CAMARO

-W

Nose	150-410-W	\$178
------	-----------	-------

*NOSE GRAPHIC ID KITS NO LONGER AVAILABLE

'97 CHEVROLET CAMARO

-W

Bumper Cover	150-450-W	\$160
--------------	-----------	-------

*BUMPER COVER GRAPHIC ID KITS NO LONGER AVAILABLE



'92 CHEVROLET CAMARO

-W -B

Nose (PAVEMENT)	140-410-x	\$178
Nose ID Kit	140-410-ID	\$39

'92 CHEVROLET CAMARO

-W -B

Nose	145-410-x	\$178
Nose ID Kit	140-410-ID	\$39



'81 CHEVROLET CAMARO

-B

Nose, Upper 210-410U-B \$80

*NOSE GRAPHIC ID KITS NO LONGER AVAILABLE

'81 CHEVROLET CAMARO

-B

Nose, Lower 210-410L-B \$75

*NOSE GRAPHIC ID KITS NO LONGER AVAILABLE



'03 CHEVROLET MONTE CARLO

-W -B

Nose (FIBERGLASS SPORTSMAN)	639-410-x	\$178
Nose (SHORT TRACK)	640-410-x	\$178
Nose ID Kit	630-410-ID	\$39

'03 CHEVROLET MONTE CARLO

-W -B

Bumper Cover	630-450-x	\$160
Bumper Cover ID Kit	630-450-ID	\$38



'94 CHEVROLET LUMINA

-W

Nose 610-410-W \$178

*NOSE GRAPHIC ID KITS NO LONGER AVAILABLE

'94 CHEVROLET LUMINA

-W

Bumper Cover 610-450-W \$160

*BUMPER COVER GRAPHIC ID KITS NO LONGER AVAILABLE



'03 FORD TAURUS

-W -B

Nose	550-410-x	\$178
------	-----------	-------

**NOSE GRAPHIC ID KITS NO LONGER AVAILABLE*

'03 FORD TAURUS

-W -B

Bumper Cover	550-450-x	\$160
--------------	-----------	-------

**BUMPER COVER GRAPHIC ID KITS NO LONGER AVAILABLE*



'97 FORD THUNDERBIRD

-W

Nose	530-410-W	\$178
------	-----------	-------

**NOSE GRAPHIC ID KITS NO LONGER AVAILABLE*

'97 FORD THUNDERBIRD

-W

Bumper Cover	530-450-W	\$160
--------------	-----------	-------

**BUMPER COVER GRAPHIC ID KITS NO LONGER AVAILABLE*



PONTIAC GRAND PRIX

-W -B

Nose	360-410-x	\$164
Nose ID Kit	360-410-ID	\$39

PONTIAC GRAND PRIX

-W -B -CB -R

Bumper Cover	460-450-x	\$155	\$160
--------------	-----------	-------	-------

**BUMPER COVER GRAPHIC ID KITS NO LONGER AVAILABLE*



'97 OLDSMOBILE CUTLASS

-W

Nose	710-410-x	\$178
------	-----------	-------

**NOSE GRAPHIC ID KITS NO LONGER AVAILABLE*



UNIVERSAL HEADLIGHT DECALS



H00-410S: Round, small - \$8



H01-410S: Rectangle, small - \$8



H00-411S: Round, large - \$12



H01-411S: Rectangle, large - \$12

ACHIEVE MAXIMUM VINYL ADHESION BY USING MD3 ADHESION PROMOTER. DETAILS AND ORDERING INFORMATION ON PAGE 167!



» ALUMINUM NOSE SCREENS: PROTECT YOUR RADIATOR FROM DEBRIS PENETRATION

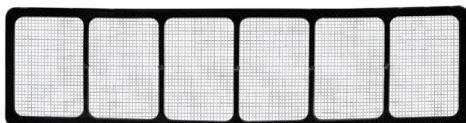

BLACK ALUMINUM FRAME

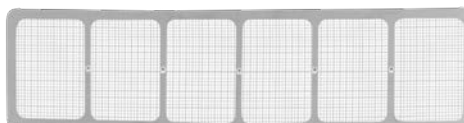

UNPAINTED

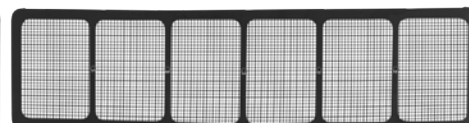

BLACK POWDER-COATED

ALUMINUM NOSE SCREENS

- » Protects the radiator from debris penetration
- » Frame is laser cut from lightweight aluminum
- » Screen is high strength stainless steel (3/16" mesh is crimped, 1/4" is welded)
- » Available options: black aluminum frame, unpainted, or with durable satin black powder-coated finish

PN	NOSE SCREEN DESCRIPTION	WIDTH (Top)	WIDTH (Bottom)	HEIGHT	MESH	
630-4111	03 Monte Carlo, Lower	34"	34"	6"	3/16"	\$50
660-4111	Common*, Lower	27-3/4"	27-3/4"	7-1/4"	3/16"	\$50
660-4111-B	Common, Lower, Black	27-3/4"	27-3/4"	7-1/4"	3/16"	\$55
660-4112	Common, Lower	27-3/4"	27-3/4"	7-1/4"	1/4"	\$50
660-4112-B	Common, Lower, Black	27-3/4"	27-3/4"	7-1/4"	1/4"	\$55
10001-46333B	Common, Lower, Black aluminum frame	27-3/4"	27-3/4"	7-1/4"	3/16"	\$55
10001-46433B	Common, Lower, Black aluminum frame	27-3/4"	27-3/4"	7-1/4"	1/4"	\$55

*COMMON NOSE SCREEN FITS THESE BODY STYLES: ABC NEXTGEN, ABC, NEXTGEN LATE MODEL STOCK CAR, LATE MODEL STOCK CAR, NORTH AMERICAN SPORTSMAN, STRAIGHT-UP METAL, MD3 CAMARO/MUSTANG STREET STOCK, DIRT GRAND NATIONAL

PRICING SUBJECT TO CHANGE WITHOUT NOTICE

REPRESENT AT THE TRACK WITH

FIVE STAR MERCHANDISE



»» PERFORMANCE HOODIE

100% POLYESTER | UNISEX SIZES: S-4XL - \$40.00



»» FIVE STAR BRAND TEE

50/50 COTTON BLEND | UNISEX SIZES: S-4XL - \$20.00



» LADIES FASHION TANK

60/40 COTTON POLY BLEND | SIZES: XS-4XL - \$20.00

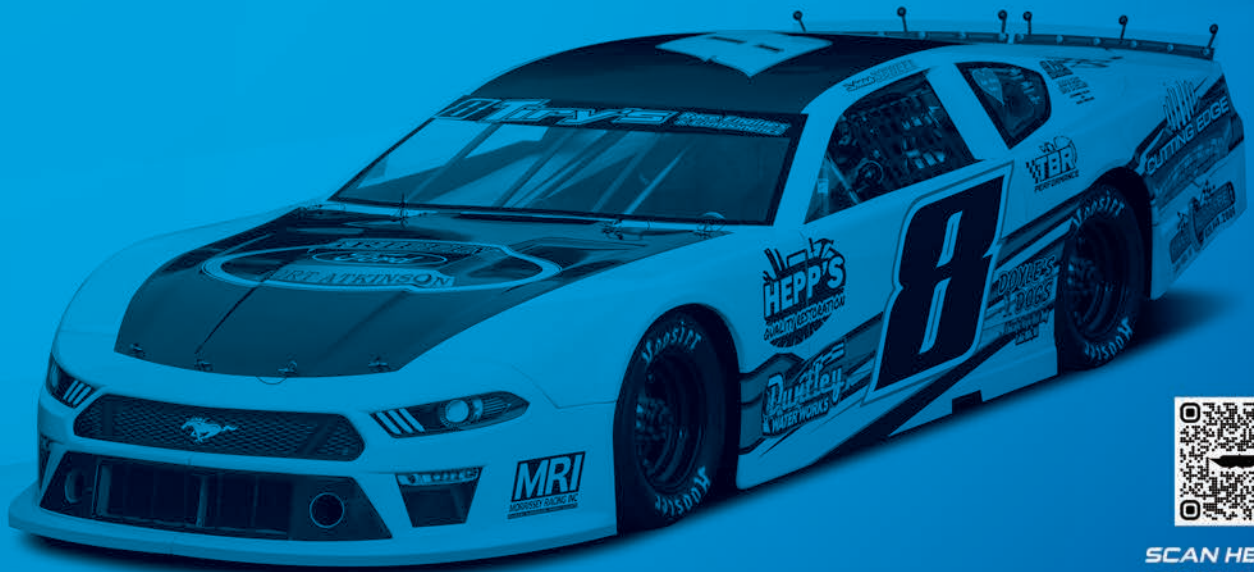

SCAN HERE TO SHOP ONLINE

#HEYNICEBODY

REPRESENT AT THE TRACK WITH

FIVE STAR

MERCHANDISE



» FIVE STAR HATS

FLEX FIT HAT | S/M & L/XL: \$20.00

TRUCKER HAT | ONE SIZE FITS ALL: \$20.00



» FIVE STAR KNIT BEANIES

100% ACRYLIC RIB KNIT | ONE SIZE UNISEX: GRAY OR BLACK: \$20.00



»FUN FIVE STAR EXTRAS!

CAN KOOZIE OR PREMIUM VINYL STICKER SETS: \$4.00 each

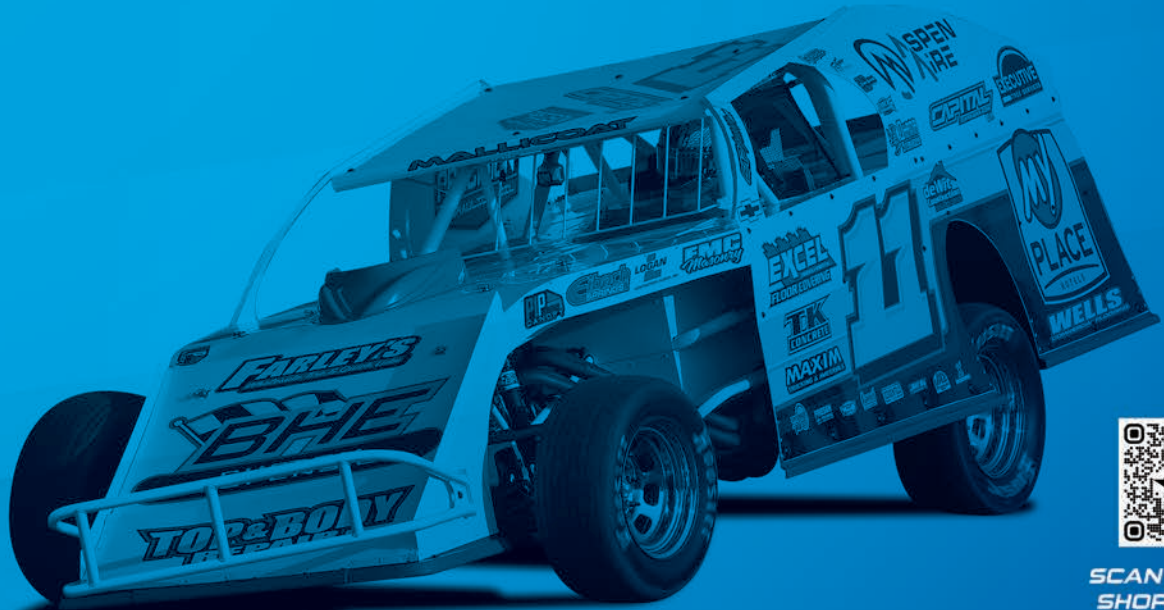

SCAN HERE TO SHOP ONLINE

#HEYNICEBODY

BODY PACKAGES & COMPONENTS

ABC NextGen.....	16
Original ABC.....	26
NextGen Late Model Stock.....	36
Short Track Truck.....	44
Pavement Modified.....	50
Outlaw Late Model.....	54
North American Sportsman.....	58
Older Body Styles.....	65
Crown Vic Interceptor.....	66
Legend And Bandolero Windows.....	67
MD3 Late Model.....	68
MD3 Modified.....	80
Northeast Modified.....	88
MD3 Stock Car.....	90
Street Stock.....	96
TA2 Road Racing.....	102
Pro Stock/Mod.....	112
Top Alcohol Funny Car.....	120
Junior Roadster.....	126

A

Air Filter Deflector

Dirt Late Model.....	77
Dirt Modified.....	85
Air Filter Shield.....	77, 85
Air Inlet Extension.....	153
Adhesion Promoter.....	33, 86, 89, 167

B

Back-Up Plate Kits

Greenhouse/Quarter.....	162
Nose/Fender.....	162

Bed Covers

Short Track Truck.....	46
------------------------	----

Bed Sides

Short Track Truck.....	46
------------------------	----

Body

Junior Dragster.....	127
Top Alcohol Funny Car.....	122

Body Mounting Kits

ABC NextGen.....	21
North American Sportsman.....	61
Original ABC.....	30
NextGen Late Model Stock Car.....	39
Short Track Truck.....	47
Body Mounting Tabs.....	164

Braces, Body

Adjustable.....	21, 30, 39, 47, 61, 163
Plastic.....	76, 86
Polycarbonate.....	163
Premium Adjustable.....	165
Custom.....	164
Nose Side.....	21, 30, 39, 47, 61, 150
Quarter Panel.....	162

Braces, Windshield

ABC NextGen.....	21, 160
NextGen Late Model Stock Car.....	39, 160
North American Sportsman.....	61, 160
Original ABC.....	30
Pavement Modified.....	160
Short Track Truck.....	47, 160
TA2 Road Racing.....	110

Braces, Window, Rear

ABC NextGen.....	21, 160
NextGen Late Model Stock Car.....	39, 160
North American Sportsman.....	61, 160
Original ABC.....	30
Pavement Modified.....	160
TA2 Road Racing.....	110

Brake Duct.....

Brake Duct.....	152
Bumpers, Front	
ABC NextGen.....	21, 148
MD3 Stock Car.....	94
NextGen Late Model Stock Car.....	43, 148
North American Sportsman.....	61, 148
Original ABC.....	30, 148
Older Body Styles.....	148

Short Track Truck.....	46, 148
Street Stock.....	148
TA2 Road Racing.....	111
Bumpers, Rear	
ABC NextGen.....	21, 156
MD3 Stock Car.....	94
NextGen Late Model Stock Car.....	39, 156
North American Sportsman.....	61, 156
Original ABC.....	30
Older Body Styles.....	156
Street Stock.....	156
Short Track Truck.....	47, 156
TA2 Road Racing.....	111

Bumper Covers, Rear

ABC NextGen.....	20
Crown Vic Interceptor.....	66
MD3 Stock Car.....	94
NextGen Late Model Stock Car.....	38
North American Sportsman.....	60
Original ABC.....	28, 29
Short Track Truck.....	46
Street Stock.....	98
TA2 Road Racing.....	104, 106, 108
Universal Short Track.....	168-170

Bumper Mounting Kits

Front.....	21, 30, 39, 46, 46, 61, 148
Complete Kit.....	148
Replacement Kit.....	148
Rear.....	21, 30, 39, 47, 61, 156
Height Adjustable.....	156
Non-Adjustable.....	156

C

Carbon Fiber Flat Sheets.....

Carbon Fiber Flat Sheets.....	119, 123
-------------------------------	----------

Chassis Clamps.....

Chassis Clamps.....	165
---------------------	-----

Clecos & Pliers.....

Clecos & Pliers.....	161
----------------------	-----

Cockpit Deflector.....

Cockpit Deflector.....	74
------------------------	----

Cold Air Boxes

2 Barrel.....	154
4 Barrel.....	154

Cowl Panel & Cowl Air Inserts

ABC NextGen.....	20, 155
North American Sportsman.....	60, 155
Original ABC.....	28, 29
Short Track Truck.....	46, 155

Cowl Air Deflector.....

Cowl Air Deflector.....	28, 29, 155
-------------------------	-------------

Cowl Bracket Tabs.....

Cowl Bracket Tabs.....	155
------------------------	-----

D

Dash

Camaro Pro Stock/Pro Mod.....	114
Mustang Pro Stock/Pro Mod.....	115

Deck Lid

ABC NextGen.....	20
Camaro Pro Stock/Pro Mod.....	114
MD3 Stock Car.....	94
Mustang Pro Stock/Pro Mod.....	115
NextGen Late Model Stock Car.....	38
North American Sportsman.....	60
Original ABC.....	28, 29
Street Stock.....	98
TA2 Road Racing.....	104, 106, 108
Deck Lid Bracket.....	94, 157

Deck Lid Filler Panel

MD3 Stock Car.....	94
Original ABC.....	28
Street Stock.....	98
TA2 Road Racing.....	108

Deck Lid Height Slider Kit.....

Deck Lid Height Slider Kit.....	157
---------------------------------	-----

Deck Lid Hold Down Strip

ABC NextGen.....	20
NextGen Late Model Stock Car.....	38
North American Sportsman.....	60
Original ABC.....	28, 29

Doors

ABC NextGen.....	20
Camaro Pro Stock/Pro Mod.....	114
Dirt Late Model.....	70, 71, 74
Dirt Modified.....	83

MD3 Stock Car.....	94
Mustang Pro Stock/Pro Mod.....	115
NextGen Late Model Stock Car.....	38
North American Sportsman.....	60
Northeast Modified.....	89
Original ABC.....	28, 29
Pavement Modified.....	52
Short Track Truck.....	46
Street Stock.....	98
TA2 Road Racing.....	104, 106, 108
Drill Bit Kit.....	161

E

Escape Hatch (Top Alcohol Funny Car).....

Escape Hatch (Top Alcohol Funny Car).....	122
---	-----

F

Fenders

ABC NextGen.....	20
Dirt Late Model.....	70, 71
MD3 Stock Car.....	94
NextGen Late Model Stock Car.....	38
North American Sportsman.....	60
Original ABC.....	28, 29
Outlaw Late Model.....	56
Short Track Truck.....	46
Street Stock.....	98
TA2 Road Racing.....	104, 106, 108

Front Clip (Body Section)

Camaro Pro Stock/Pro Mod.....	114
Mustang Pro Stock/Pro Mod.....	115

G

Graphic ID Kits (Nose & Bumper Cover)

ABC NextGen.....	21
Camaro Pro Stock/Pro Mod.....	114
Camaro Top Alcohol Funny Car.....	122
Dirt Late Model.....	79
MD3 Stock Car.....	94
Mustang Pro Stock/Pro Mod.....	115
NextGen Late Model Stock Car.....	39
North American Sportsman.....	61
Original ABC.....	30
Short Track Truck.....	47
Street Stock.....	98, 101
TA2 Road Racing.....	104, 106, 108
Universal Short Track.....	168-170

Greenhouse (Front & Rear)

ABC NextGen.....	20
NextGen Late Model Stock Car.....	38
North American Sportsman.....	60
Original ABC (Greenhouse Roof).....	29
Short Track Truck.....	46
TA2 Road Racing.....	104, 106, 108

H

Headlight Lens Covers

Camaro Pro Stock/Pro Mod.....	114
Mustang Pro Stock/Pro Mod.....	115

Heat Shield

Cold Air Box Kit.....	155
5' x 26" Length Sheet.....	155

Headlight Decals.....

Headlight Decals.....	171
-----------------------	-----

Hood

ABC NextGen.....	20
Dirt Late Model.....	70, 71, 75
MD3 Stock Car.....	94
NextGen Late Model Stock Car.....	38
North American Sportsman.....	60
Original ABC.....	28, 29
Pavement Modified.....	52
Short Track Truck.....	46
Street Stock.....	98
TA2 Road Racing.....	104, 106, 108
Hood Hinge.....	151
Hood Filler Panel.....	94

Hood Pin Brackets

ABC NextGen.....	21, 149
MD3 Stock Car.....	94
NextGen Late Model Stock Car.....	39, 149

North American Sportsman.....	61, 149
Original ABC.....	30
Older Body Styles.....	149
Short Track Truck.....	46, 149
Street Stock.....	149
TA2 Road Racing.....	111
Hood Pin Kits.....	21, 30, 39, 46, 61, 149
Hood Prop.....	151
Hood Scoops	
Dirt Late Model.....	72
Dirt Modified.....	84
Pavement Modified.....	52

M	
Mirror.....	111, 166
Mounting Bracket.....	166

N	
Noses	
ABC NextGen.....	20
Crown Vic Interceptor.....	66
Dirt Late Model.....	70, 71
Dirt Modified.....	82
MD3 Stock Car.....	94
NextGen Late Model Stock Car.....	38
North American Sportsman.....	60
Original ABC.....	28, 29
Outlaw Late Model.....	56
Pavement Modified.....	52
Short Track Truck.....	46
Street Stock.....	98
TA2 Road Racing.....	104, 106, 108
Universal Short Track.....	168-170
Nose Lower Aero Valance.....	70, 71, 82
Nose Filler Panel	
Dirt Late Model.....	70, 71, 72
Dirt Modified.....	82
Outlaw Late Model.....	56
Pavement Modified.....	52
Nose Screens.....	21, 30, 39, 46, 56, 61, 94, 101, 110, 171
Nose Support, Lower	
Dirt Late Model.....	76
Outlaw Late Model.....	56
Nose Support Bracket.....	150

O	
Oil Cooler Scoop	
Dirt Late Model.....	76
Dirt Modified.....	86
P	
Parachute Boxes (Top Alcohol Funny Car).....	122
Plastic Flat Sheets.....	78, 87
Polycarbonate Flat Sheets.....	131

Q	
Quarter Panels	
ABC NextGen.....	20
Dirt Late Model.....	70, 71, 74
Dirt Modified.....	83
MD3 Stock Car.....	94
NextGen Late Model Stock Car.....	38
North American Sportsman.....	60
Northeast Modified.....	89
Original ABC (Traditional Roof).....	28
Original ABC (Greenhouse Roof).....	29
Pavement Modified.....	52
Street Stock.....	98
TA2 Road Racing.....	104, 106, 108

R	
Radiator Ducts.....	152-153
Rear Cab Filler.....	46
Rear Clip (Body Section)	
Camaro Pro Stock/Pro Mod.....	114
Mustang Pro Stock/Pro Mod.....	115
Rear Deck Mounting Kit.....	21, 30, 39, 61, 94, 157
Rear Filler Panel	
Pavement Modified.....	52
Short Track Truck.....	46
Referee 2.0.....	24, 34, 42
Body Centerline Device.....	24, 34, 42
Laser Measurement Assembly.....	24, 34, 42
Wheel Locator with Magnets.....	24, 34, 42
Right Side Door Support.....	21, 30, 47, 161
Rivets.....	146
Rocker Panels.....	20, 28, 29, 38, 46, 52, 56, 60, 70, 71, 74, 83, 84, 89, 94, 159

Roof	
Dirt Late Model.....	70, 71, 75
MD3 Stock Car.....	94
Original ABC (Traditional Roof).....	28
Outlaw Late Model.....	56
Pavement Modified.....	52
Street Stock.....	98
Roof Caps.....	70, 71, 75
Roof Locating Fixture.....	24, 34, 42, 64
Replacement Door Height Blocks.....	24, 34, 42, 64
Replacement Roof Brackets.....	24, 34, 42, 64
Rub Rail, Polycarbonate.....	159

S	
Sail Panels	
Outlaw Late Model.....	56
Pavement Modified.....	52
Spill Plates	
Camaro Pro Stock/Pro Mod.....	114
Camaro Top Alcohol Funny Car.....	122
Mustang Pro Stock/Pro Mod.....	115
Splitter	
TA2 Road Racing.....	111
Spoilers	
ABC NextGen.....	20, 158
Camaro Pro Stock/Pro Mod.....	114
Dirt Late Model.....	73
Mustang Pro Stock/Pro Mod.....	115
NextGen Late Model Stock Car.....	38
North American Sportsman.....	60, 158
Original ABC.....	28, 29
Pavement Modified.....	52
Short Track Truck.....	46
Street Stock.....	98
Spoiler Mounting Kit.....	158

T	
Tail Light Covers (Mustang Pro Stock/Pro Mod).....	115
Templates	
ABC NextGen.....	25
Camaro Pro Stock/Pro Mod.....	117
Mustang Pro Stock/Pro Mod.....	117
NextGen Late Model Stock Car.....	43
North American Sportsman.....	64
Original ABC.....	35
Short Track Truck.....	49
TA2 Road Racing.....	105, 107
Tethered Burst Panel (Top Alcohol Funny Car).....	122

U	
Universal Body Mounting Kit.....	21, 30, 39, 47, 61, 147
Universal Tubing Kit.....	163

V	
Valance, Lower Aero	
Dirt Late Model.....	70, 71
Dirt Modified.....	82
Valance, Lower Aero Support.....	82

W	
Washers.....	146
Wear Strips.....	21, 30, 39, 47, 61, 147
Wheel Flares	
Dirt Modified.....	84
Pavement Modified.....	52

Windshields	
ABC NextGen.....	20
Bandolero.....	67
Camaro Pro Stock/Pro Mod.....	114
Camaro Top Alcohol Funny Car.....	122
Crown Vic Interceptor.....	66
Junior Dragster.....	127
Legend Car.....	67
Mustang Pro Stock/Pro Mod.....	115
NextGen Late Model Stock Car.....	38
North American Sportsman.....	60
Original ABC.....	28, 29
Outlaw Late Model.....	60
Pavement Modified.....	52
Short Track Truck.....	46
Street Stock.....	98
TA2 Road Racing.....	104, 106, 108
Windshield Black-out Kit.....	98
Windshield Braces.....	See Braces
Window Braces.....	See Braces
Window Cleaner.....	33, 137, 167
Window, Door.....	114, 115, 122
Window, Door Vent.....	21, 30, 39, 61, 104, 106, 166
Window Installation Kit.....	21, 30, 39, 47, 61, 118, 127, 137, 160
Window Countersink Drill Bit.....	137, 160

Window, Quarter	
ABC NextGen.....	20
Camaro Pro Stock/Pro Mod.....	114
MD3 Stock Car.....	94
Mustang Pro Stock/Pro Mod.....	115
NextGen Late Model Stock Car.....	38
North American Sportsman.....	60
Original ABC.....	28, 29
Outlaw Late Model.....	56
Pavement Modified.....	52
Street Stock.....	98
TA2 Road Racing.....	104, 106, 108

Window, Rear	
ABC NextGen.....	20
Camaro Pro Stock/Pro Mod.....	114
Mustang Pro Stock/Pro Mod.....	115
NextGen Late Model Stock Car.....	38
North American Sportsman.....	60
Original ABC.....	28, 29
Outlaw Late Model.....	56
Pavement Modified.....	52
Short Track Truck.....	46
Street Stock.....	98
TA2 Road Racing.....	104, 106, 108
Windows, Universal Aftermarket.....	143
Windows, Drag Racing Aftermarket.....	138
Windows, Factory Stock.....	132
Windows, Custom.....	131

GO TO FIVESTARBODIES.COM

TERMS &



CONDITIONS

SHIPPING



INFORMATION

Meet The Five Star

SALES & MARKETING TEAM

Thanks to the dedication of our employees, you, our valued customer can be assured of receiving a level of personalized service unsurpassed in the industry!



» **BRIAN HOPPE**
Key Accounts Manager
Team Member Since 2019



» **CAMERON FRIEDEN**
Sales / Project Manager
Team Member Since 2019



» **RICH WATSON**
Sales / Customer Service
Team Member Since 2019



» **CHRIS WIESS**
Sales / Customer Service
Team Member Since 2019



» **DAN ROBINSON**
MD3 Product Manager
Team Member Since 2022



» **DANIEL SANCHEZ**
Marketing Manager
Team Member Since 2021



**COME SEE THE ALL NEW
FIVE STAR SPRINTER VAN
AT A TRACK NEAR YOU!**

Five Star Family Values

DRIVE OUR BUSINESS TOWARDS SUCCESS!



» CARL SCHULTZ



» COREY SCHULTZ



» GARRETT SCHULTZ



» HALEY SCHULTZ



» HEIDI SCHULTZ

One of our great sources of pride at Five Star is the fact that we are a family-owned business. Our values as a family help guide our management of the business, and Carl takes great joy in knowing the company he has led to date is in good hands going forward. Each family member takes an active role in the day-to-day operations and looks forward to building on the legacy Carl has built for years to come.

We use the values of the Schultz Family as a guiding philosophy for running the business. These values are as follows:

CUSTOMER FOCUS

Cultivate Lasting Relationships Based on Trust, Reliability & Exceptional Service

EXCELLENCE

Uphold the Highest Ethical & Professional Standards in All Our Actions

DEDICATION

Fully Invest Ourselves in Our Roles, Team & Company

INNOVATION

Strive for Continuous Learning & Improvement in All Aspects of Work

WINNING

Be Leaders, Not Followers in Every Market We Serve

We are committed to these values and they are reflected in every area of our lives and how we do business. The adoption of these core values is essential to executing our strategy and ensuring a work environment that supports The Company's objectives and inspires employees to new levels of productivity, helping them achieve their professional goals. We are confident in our ability to execute on our strategies making Five Star a fun, rewarding place to work.





ENGINEERED THROUGH THE RACER'S EYES

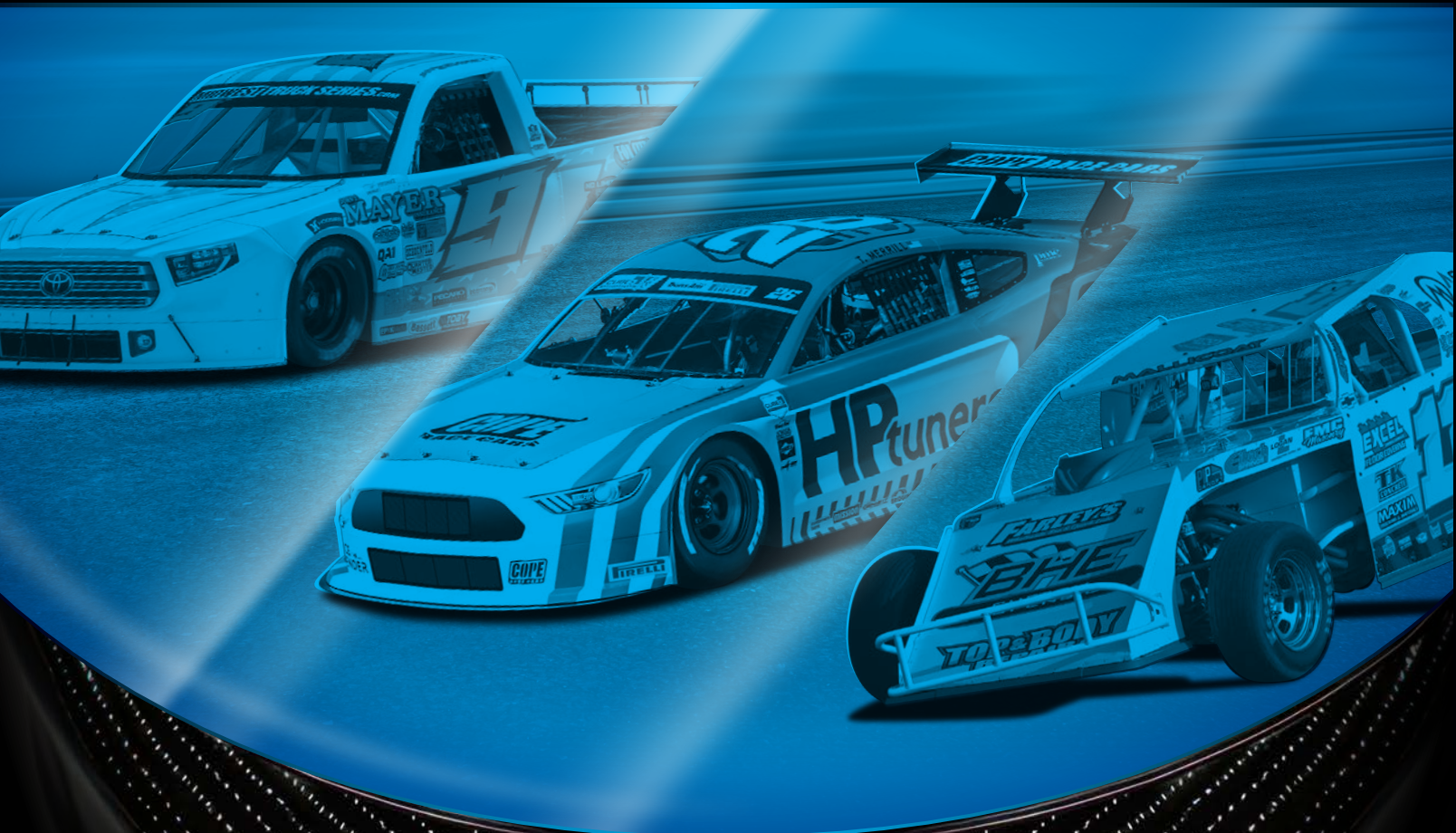

2025
CATALOG



FIVESTARBODIES.COM | MD3RACE.COM
FIVESTARFABRICATING.COM

PO BOX 700 | 8899 368TH AVE | TWIN LAKES, WI 53181

262.877.2171