

PRO STOCK BODY DIMENSIONS

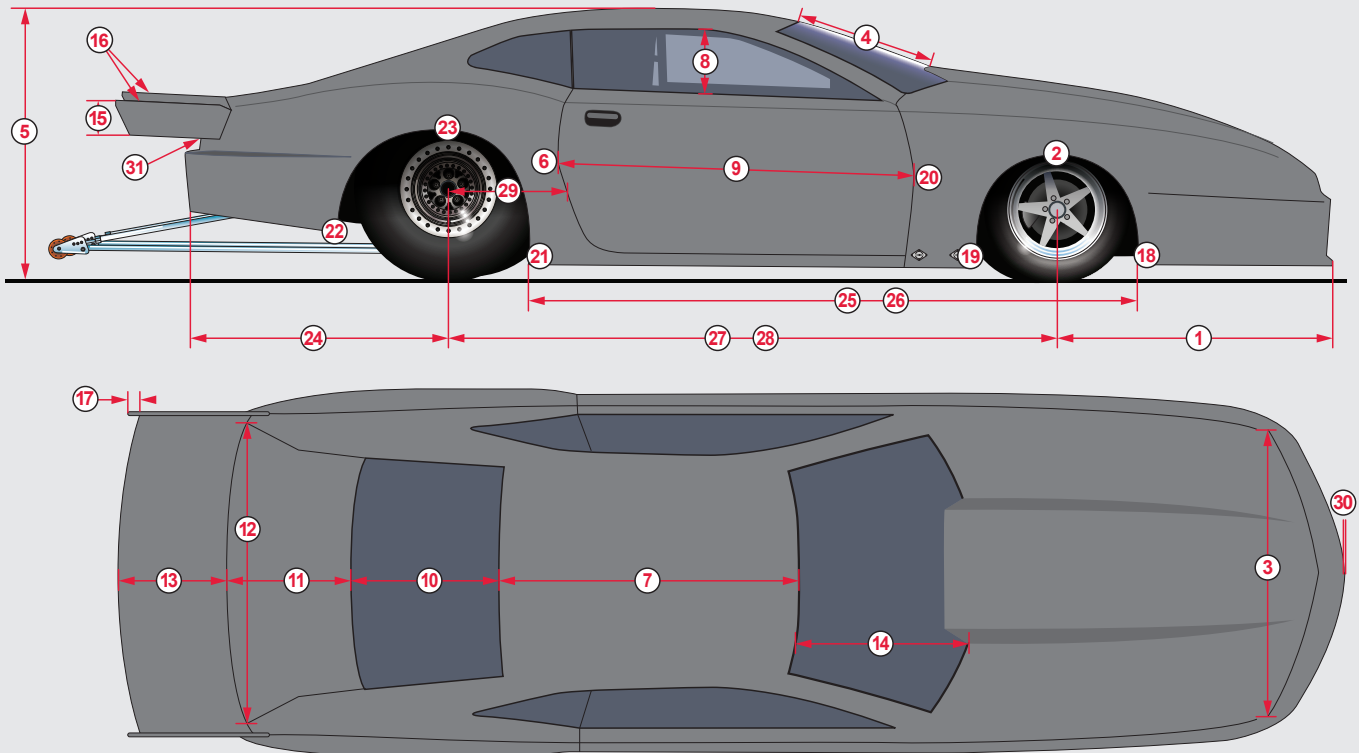

**** All measurements are zero tolerance unless otherwise noted ****

NO.	LOCATION	DETAILS	DODGE DART
1.	Front Overhang	Measured from long side of wheelbase center to front edge of body (splitter not included)	45.00
2.	Width	Over Spindle	64.25
3.	Front Fascia Width	Measured across the front end at upper/outer corners of headlight recessed area	36.25
4.	Windshield Length Center	Measured from top center of windshield down to rear of hood/cowl center	26.25
5.	Overall Height	Measurement taken from the highest point of roof to rear of rocker	44.00 min
6.	Width (at B-Post)	Measurement taken 15" up from bottom of rocker, +/-0.25"	64.75
7.	Roof Length		59.25
8.	Side Window Height	Measurement taken at tallest point	15.125
9.	Door Length	Measurement taken at upper body line	48.25
10.	Rear Window Length		28.875
11.	Deck Lid Length	Measurement taken from bottom of rear window center	22.875
12.	Deck Lid Width	Measurement taken across rear of deck lid	46.25
13.	Spoiler Length	Length does not include wicker height. Minimum 0.75" height for wicker. Must be 90°	14.00
14.	Windshield Length	Measurement taken 12" inward from bottom corner of windshield. From this point, go to top of windshield, parallel to center line of body	26.00 min
15.	Spill Plate Height	+/-0.125"	6.00
16.	Section of Spill Plate above Spoiler	+/-0.125"	1.00
17.	Spill Plate Extension past rear of Spoiler		2.00 max
18.	Width in Front of Front Tire	Measurement taken at bottom of opening. +/-0.25"	62.125
19.	Width Behind Front Tire	Measurement taken 10" from front of rocker. +/-0.25"	62.75
20.	Width at Front Edge of Door	Measurement taken at widest point, +/-0.25"	64.75
21.	Width in Front of Rear Tire	Measurement taken at bottom of rocker. +/-0.25"	65.50
22.	Width Behind Rear Tire	Measurement taken at bottom of panel, widest point, +/-0.25"	61.625
23.	Width at Center of Rear Axle	+/-0.25"	66.25
24.	Rear Overhang	Measurement taken from the center of the rear axle to the center of bumper at furthest point above wheelie bar opening, +/-0.25"	45.50
25.	Length Left Hand Side	Measurement taken from rear of rocker to front edge of front wheel opening. +/-0.25"	100.25
26.	Length Right Hand Side	Measurement taken from rear of rocker to front edge of front wheel opening. +/-0.25"	99.25
27.	Wheelbase - Max		105.00
28.	Wheelbase - Min		104.00
29.	B-Post to Centerline of rear axle	+/-0.25"	33.00
30.	Splitter Length	Amount of 2.375" total length front splitter mounted in front of body (see NHRA Rulebook for more info)	0.375
31.	Length of Spill Plate		26.00 max
32.	B-Post Location	Measurement taken from bottom of rocker	15.00